



DEPENDABLE EMERGENCY VEHICLES
A DIVISION OF DEPENDABLE TRUCK AND TANK LIMITED
275 Clarence Street, Brampton ON L6W 3R3
905-453-6724
www.dependable.ca

May 18 2023

Lucknow District Fire Department
PO Box 580
Lucknow, Ontario
N0G 2H0

Fire Chief Chris Cleave,

Thank you for the opportunity to provide you with a formal quote on a custom-built Acres Dependable Vortex Pumper as per your request. Dependable Emergency Vehicles produces high-quality, cost-effective emergency vehicles that have been proven in the emergency response industry for over 40 years. From conception, to building and delivery, Dependable is able to support you throughout the acquisition process, and during the entire lifetime of the vehicle. We look forward to the opportunity to work with you and your department in delivering a high-quality apparatus which has been **“DESIGNED TO PERFORM, BUILT TO LAST”** for many years to come.

Supply One (1) Acres Dependable Vortex Pumper

Proposal #14284 \$695,592.00 + HST

Included:

- Ontario PMCVI inspection
- FOB: Brampton, Ontario

***Please note: This quote is valid for 15 days. The estimated delivery date of this apparatus is to be determined as the chassis is in stock however it is on a first come first serve basis and only a firm purchase order will secure the chassis. A 30% deposit is required on order, balance is due on pickup of the apparatus.

If you have any further questions or concerns, please don't hesitate to contact me.

Thank you,

Pino Natale

Pino Natale
Director of Emergency Vehicles Division
416-561-6724 | pino@dependable.ca

EMERGENCY APPARATUS PROPOSAL

Proposal #14284

Date - May 11, 2023



Emergency Apparatus Proposal for
Lucknow Fire Dept.
VORTEX series Pumper Apparatus

Acres Industries Inc

200 Green Acres Road
Wawanesa, MB R0K 2G0

Ph 204 824 2392
Fax 204 824 2761
www.acresev.ca

Company Profile

Acres Industries Inc is located just outside Wawanesa, Manitoba and is owned and operated by the Green Acres Hutterite Colony. The business started in the mid 1990's, providing service to the local agriculture & livestock industries. Acres built its first emergency vehicle in the late 1990's, and since then has exclusively focused on designing and manufacturing emergency vehicles built to a high standard of quality.

The manufacturing facility is housed in a new, energy efficient building heated and cooled by geo-thermal systems.

Late model CNC machinery is used in the manufacturing process to cut the material, sand and de-burr the material, form the material & weld the material. This allows us to maintain the high fit/finish reputation, Acres is known for.

Acres designs and uses aluminum profiles in its manufacturing process. These profiles are proprietary, extruded in North America and provide for one of the finest and most durable fire service bodies in Canada. These profiles are placed in all four corners of compartments with the compartment side panels interlocking in grooves. This body concept supports and transfers body loads to the chassis frame rails with un-interrupted structural members, providing a life-time of hassle-free, low-cost reliable service.

Multi-plexed electrical systems are utilized on our apparatus. This technology has proven to be extremely reliable and when integrated with the chassis, allows for enhanced functions, safety features & diagnostics. Electrical harnesses and power distribution circuitry exceed the industry standards.

Acres is a member of MAFC (Manitoba Association of Fire Chiefs).

Acres is a member of SAFC (Saskatchewan Association of Fire Chiefs).

Acres is a member of AFCA (Alberta Fire Chiefs Association).

Acres is CWB (Canadian Welding Bureau) certified, and our facilities are audited annually.

Acres is a Member of FAMA (Fire Apparatus Manufacturers Association)

Acres is a Member of NFPA (National Fire Protection Association)

Acres is a Member of CTEA (Canadian Transport Equipment Association)

Acres maintains and is in good standing with WCB (Workers Compensation Board)

Acres employ's Journeymen Welders, Journeymen Electricians, Certified Engineering Technologists and Professional Engineers, all with a common vision for excellence!

At Acres, quantity is not our primary goal, much rather to develop an excellent emergency vehicle that you, our customer will be proud of, and that will serve the people in your community reliably for many years with low life-cycle operating costs.

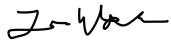

Sincerely, Tim Waldner
General Manager



HV607 SBA

Sales Proposal For:
Acres Emergency Vehicles

Presented By:
Maxim Truck & Trailer

Prepared For:

Acres Emergency Vehicles
TIM WALDNER
P.O. Box 279
Wawanesa, MB R0K 2G0
(204)824 - 2392 Reference

Presented By:

Maxim Truck & Trailer
Shayne Garwood
1860 Brookside Blvd.
Winnipeg MB R3C 2E6
(204)790-6599

Thank you for the opportunity to provide you with the following quotation on a new International truck. I am sure the following detailed specification will meet your operational requirements, and I look forward to serving your business needs.

Model Profile
2022 HV607 SBA (HV607)

AXLE CONFIG: 4X2
APPLICATION: Fire/Pumper (Emergency)
MISSION: Requested GVWR: 40000. Calc. GVWR: 40000
Calc. Start / Grade Ability: 0.00% / 0.00% @ 0 MPH
Calc. Geared Speed: N/A
DIMENSION: Wheelbase: 248.00, CA: 137.00, Axle to Frame: 67.00
ENGINE, DIESEL: {Cummins L9 350} EPA 2021, 350HP @ 2200 RPM, 1050 lb-ft Torque @ 1200 RPM, 2200 RPM
Governed Speed, 350 Peak HP (Max)
TRANSMISSION, AUTOMATIC: {Allison 3000 EVS} 5th Generation Controls, Close Ratio, 6-Speed with Double Overdrive, with
PTO Provision, Less Retarder, Includes Oil Level Sensor
CLUTCH: Omit Item (Clutch & Control)
AXLE, FRONT NON-DRIVING: {Meritor MFS-14-143A} Wide Track, I-Beam Type, 14,000-lb Capacity
AXLE, REAR, SINGLE: {Dana Spicer S26-190D} Single Reduction, 26,000-lb Capacity, Driver Controlled Locking
Differential, R Wheel Ends Gear Ratio: 5.38
CAB: Conventional 6-Man Crew Cab
TIRE, FRONT: (2) 315/80R22.5 Load Range L UNISTEEL G291 (GOODYEAR), 491 rev/mile, 68 MPH, All-
Position
TIRE, REAR: (4) 12R22.5 Load Range H G622 RSD (GOODYEAR), 482 rev/mile, 75 MPH, Drive
SUSPENSION, REAR, SINGLE: 31,000-lb Capacity, Vari-Rate Springs, with 4500-lb Capacity Auxiliary Rubber Springs
PAINT: Cab schematic 100WL
Location 1: 2303, Red (Std)
Chassis schematic N/A

Vehicle Specifications 2022 HV607 SBA (HV607)

<u>Code</u>	<u>Description</u>
HV60700	Base Chassis, Model HV607 SBA with 248.00 Wheelbase, 137.00 CA, and 67.00 Axle to Frame.

AXLE CONFIGURATION

1ANA	AXLE CONFIGURATION {Navistar} 4x2 <u>Notes</u> : Pricing may change if axle configuration is changed.
------	---

ENGINE

12ESN	ENGINE, DIESEL {Cummins L9 350} EPA 2021, 350HP @ 2200 RPM, 1050 lb-ft Torque @ 1200 RPM, 2200 RPM Governed Speed, 350 Peak HP (Max)
12UAW	RADIATOR Aluminum, 2-Row, Cross Flow, Over Under System, 1045 SqIn Louvered, with 373 SqIn Charge Air Cooler, Includes In-Tank Oil Cooler <u>Includes</u> : DEAERATION SYSTEM with Surge Tank : HOSE CLAMPS, RADIATOR HOSES Gates Shrink Band Type; Thermoplastic Coolant Hose Clamps : RADIATOR HOSES Premium, Rubber
12THT	FAN DRIVE {Horton Drivemaster} Two-Speed Type, Direct Drive, with Residual Torque Device for Disengaged Fan Speed <u>Includes</u> : FAN Nylon
12VBR	AIR CLEANER with Service Protection Element
12703	ANTI-FREEZE Red, Extended Life Coolant; To -40 Degrees F/ -40 Degrees C, Freeze Protection
12WUL	BLOCK HEATER, ENGINE {Phillips} 120V/1000W, with "Y" Cord for Dealer Installed 120V/300W Oil Pan Heater <u>Includes</u> : BLOCK HEATER SOCKET Receptacle Type; Mounted below Drivers Door
12XBM	ENGINE CONTROL, REMOTE MOUNTED Provision for; Includes Wiring for Body Builder Installation of PTO Controls and Starter Lockout, with Ignition Switch Control, for Cummins B6.7 and L9 Engines
12WBR	FAN OVERRIDE Manual; with Electric Switch on Instrument Panel, (Fan On with Switch On)
12VHR	FEDERAL EMISSIONS {Cummins L9} EPA, OBD and GHG Certified for Calendar Year 2021
12VXU	THROTTLE, HAND CONTROL Engine Speed Control for PTO; Electronic, Stationary Pre-Set, Two Speed Settings; Mounted on Steering Wheel

TRANSMISSION

13AUK	TRANSMISSION, AUTOMATIC {Allison 3000 EVS} 5th Generation Controls, Close Ratio, 6-Speed with Double Overdrive, with PTO Provision, Less Retarder, Includes Oil Level Sensor
13WUE	ALLISON SPARE INPUT/OUTPUT for Emergency Vehicle Series (EVS), Fire/Pumper, Tank, Aerial/Ladder, Package Number 198
13WVW	NEUTRAL AT STOP OMIT
13XAL	PTO LOCATION Customer Intends to Install PTO at Left Side of Transmission
13WYU	SHIFT CONTROL PARAMETERS {Allison} 3000 or 4000 Series Transmissions, Performance Programming
13WLP	TRANSMISSION OIL Synthetic; 29 thru 42 Pints

<u>Code</u>	<u>Description</u>
13WET	TRANSMISSION SHIFT CONTROL Column Mounted Stalk Shifter, Not for Use with Allison 1000 & 2000 Series Transmission

CLUTCH

11001	CLUTCH Omit Item (Clutch & Control)
-------	-------------------------------------

REAR AXLES, SUSPENSIONS

14AHL	AXLE, REAR, SINGLE {Dana Spicer S26-190D} Single Reduction, 26,000-lb Capacity, Driver Controlled Locking Differential, R Wheel Ends . Gear Ratio: 5.38
14VAJ	SUSPENSION, REAR, SINGLE 31,000-lb Capacity , Vari-Rate Springs, with 4500-lb Capacity Auxiliary Rubber Springs

FRONT AXLES

2ARV	AXLE, FRONT NON-DRIVING {Meritor MFS-14-143A} Wide Track, I-Beam Type, 14,000-lb Capacity
------	---

FRONT SUSPENSIONS

3ADD	SUSPENSION, FRONT, SPRING Parabolic Taper Leaf, Shackle Type, 14,000-lb Capacity, with Shock Absorbers
------	--

CABS, COWLS, BODIES

16196	CAB Conventional 6-Man Crew Cab
16ZBU	ACCESS, CAB Steel, Driver & Passenger Sides, Two Steps per Door, for use with Crew Cab
16BAM	AIR CONDITIONER with Integral Heater and Defroster
16VKD	CAB INTERIOR TRIM Classic, for Crew Cab <u>Includes</u> : CONSOLE, OVERHEAD Molded Plastic with Dual Storage Pockets, Retainer Nets and CB Radio Pocket; Located Above Driver and Passenger : DOME LIGHT, CAB Door Activated and Push On-Off at Light Lens, Timed Theater Dimming, Integral to Overhead Console, Center Mounted : SUN VISOR (2) Padded Vinyl; 2 Moveable (Front-to-Side) Primary Visors, Driver Side with Toll Ticket Strap
16XCW	CAB, INTERIOR TRIM, CLOSEOUT Under IP, Driver Side
16WSK	CAB REAR SUSPENSION Air Bag Type
16WEE	CAB SOUND INSULATION Includes Dash Insulator and Engine Cover Insulator
16GDE	GAUGE CLUSTER Base Level; Metric with Metric Speedometer and Tachometer, for Air Brake Chassis, Includes Engine Coolant Temperature, Primary and Secondary Air Pressure, Fuel and DEF Gauges, Oil Pressure Gauge, Includes 3 Inch Monochromatic Text Display
16HHE	GAUGE, AIR CLEANER RESTRICTION {Filter-Minder} with Black Bezel, Mounted in Instrument Panel
16HGH	GAUGE, OIL TEMP, AUTO TRANS for Allison Transmission
16SEE	GRAB HANDLE, EXTERIOR Chrome, Towel Bar Type, with Anti-Slip Rubber Inserts, for Cab Entry Mounted Left Side at B-Pillar
16GHV	GRAB HANDLE, CAB INTERIOR (4) Safety Yellow, Crew Cab
16XJN	INSTRUMENT PANEL Flat Panel
16HKT	IP CLUSTER DISPLAY On Board Diagnostics Display of Fault Codes in Gauge Cluster

Vehicle Specifications 2022 HV607 SBA (HV607)

<u>Code</u>	<u>Description</u>
16SNU	MIRRORS (2) Aero Pedestal, Power Adjust, Heated, Bright Heads, Black Arms, 6.5" x 14" Flat Glass, Includes 6.5" x 6" Convex Mirrors, for 102" Load Width
	<u>Notes</u> : Mirror Dimensions are Rounded to the Nearest 0.5"
16VCA	SEAT BELT All Red; 4 to 6
16JGJ	SEAT, DRIVER {H.O. Bostrom Sierra Air 100} NFPA Compliant, Air Suspension, High Back, Vinyl with Covered Back and International Logo on Headrest, for Fire Truck
16PXH	SEAT, PASSENGER {H.O. Bostrom Tanker 450} for SCBA; Non-Suspension, High Back, Vinyl with Covered Back, International Logo on Headrest, Adjusters, 7-Degree Back Angle
16RZL	SEAT, REAR {H.O. Bostrom Tanker 400CT} for SCBA; Three Individual Seats on One Riser, Non Suspension, High Back, Vinyl, with Covered Back and International Logo on Headrest
16XWD	SUNSHADE, EXTERIOR Aerodynamic, Painted Roof Color, with Integral Clearance/Marker Lights
16XCL	WINDOW, MANUAL (4) and Manual Door Locks, Front and Rear Doors, Left and Right

FRAMES

1CAJ	FRAME RAILS Heat Treated Alloy Steel (120,000 PSI Yield); 10.866" x 3.622" x 0.437" (276.0mm x 92.0mm x 11.1mm); 456.0" (11582mm) Maximum OAL
1WMS	BUMPER EXTENSION, FRONT 2.0"
1LNN	BUMPER, FRONT Contoured, Steel, Chrome Plated
1MEJ	FRAME, SPECIAL EFFECTS Dimple on Left and Right Top Flange of Frame Rail to Reference Rear Axle Centerline
1570	TOW HOOK, FRONT (2) Frame Mounted
1WGS	WHEELBASE RANGE 189" (480cm) Through and Including 256" (650cm)

BRAKES

4091	BRAKE SYSTEM, AIR Dual System for Straight Truck Applications <u>Includes</u> : BRAKE LINES Color and Size Coded Nylon : DRAIN VALVE Twist-Type : GAUGE, AIR PRESSURE (2) Air 1 and Air 2 Gauges; Located in Instrument Cluster : PARKING BRAKE CONTROL Yellow Knob, Located on Instrument Panel : PARKING BRAKE VALVE For Truck : QUICK RELEASE VALVE On Rear Axle for Spring Brake Release: 1 for 4x2, 2 for 6x4 : SPRING BRAKE MODULATOR VALVE R-7 for 4x2, SR-7 with relay valve for 6x4/8x6
4AZS	AIR BRAKE ABS {Bendix AntiLock Brake System} 4-Channel (4 Sensor/4 Modulator) Electronic Stability Program, with Automatic Traction Control
4XDP	BRAKES, FRONT {Meritor 16.5X5 Q-PLUS CAST} Air S-Cam Type, Cast Spider, Fabricated Shoe, Double Anchor Pin, Size 16.5" X 5", 14,600-lb Capacity
4EXV	BRAKE CHAMBERS, FRONT AXLE {Bendix} 24 Sqli
4LAG	SLACK ADJUSTERS, FRONT {Gunite} Automatic
4WBX	DUST SHIELDS, FRONT BRAKE for Air Cam Brakes
4XCZ	BRAKES, REAR {Meritor 16.5X7 P} Air S-Cam Type, Cast Spider, Cast Shoe, Double Anchor Pin, Includes Greaseable and Zinc Coated Anchor Pins, Size 16.5" X 7", 38,000-lb Capacity per Axle

Vehicle Specifications
2022 HV607 SBA (HV607)

<u>Code</u>	<u>Description</u>
4EXU	BRAKE CHAMBERS, REAR AXLE {Bendix EverSure} 30/30 SqIn Spring Brake
4LGG	SLACK ADJUSTERS, REAR {Gunitite} Automatic
4WDM	DUST SHIELDS, REAR BRAKE for Air Cam Brakes
4SPA	AIR COMPRESSOR {Cummins} 18.7 CFM
4EBD	AIR DRYER {Wabco System Saver 1200} with Heater
4VKC	AIR DRYER LOCATION Mounted Inside Left Rail, Back of Cab
4VDU	AIR TANK LOCATION (2) Mounted Left Side BOC Under Battery Box
4722	DRAIN VALVE {Bendix DV-2} Automatic, with Heater, for Air Tank

STEERING

5PSA	STEERING GEAR {Sheppard M100} Power
5710	STEERING COLUMN Tilting and Telescoping
5CAW	STEERING WHEEL 4-Spoke; 18" Dia., Black

DRIVELINES

6DGG	DRIVELINE SYSTEM {Dana Spicer} 1710, for 4x2/6x2
------	--

EXHAUST SYSTEMS

7BLW	EXHAUST SYSTEM Horizontal Aftertreatment System, Frame Mounted Right Side Under Cab, for Single Vertical Tail Pipe, Frame Mounted Right Side Back of Cab
7BEU	AFTERTREATMENT COVER Aluminum
7SCP	ENGINE EXHAUST BRAKE for Cummins ISB/B6.7/ISL/L9 Engine with Variable Vane Turbo Charger
7WCR	EXHAUST HEIGHT 10' 11"
7WBS	MUFFLER/TAIL PIPE GUARD (1) Bright Stainless Steel
7WBA	TAIL PIPE (1) Turnback Type, Bright

ELECTRICAL SYSTEMS

8000	<p>ELECTRICAL SYSTEM 12-Volt, Standard Equipment</p> <p><u>Includes</u></p> <ul style="list-style-type: none"> : DATA LINK CONNECTOR For Vehicle Programming and Diagnostics In Cab : HAZARD SWITCH Push On/Push Off, Located on Instrument Panel to Right of Steering Wheel : HEADLIGHT DIMMER SWITCH Integral with Turn Signal Lever : PARKING LIGHT Integral with Front Turn Signal and Rear Tail Light : STARTER SWITCH Electric, Key Operated : STOP, TURN, TAIL & B/U LIGHTS Dual, Rear, Combination with Reflector : TURN SIGNAL SWITCH Self-Cancelling for Trucks, Manual Cancelling for Tractors, with Lane Change Feature : WINDSHIELD WIPER SWITCH 2-Speed with Wash and Intermittent Feature (5 Pre-Set Delays), Integral with Turn Signal Lever : WINDSHIELD WIPERS Single Motor, Electric, Cowl Mounted : WIRING, CHASSIS Color Coded and Continuously Numbered
8GHK	ALTERNATOR {Delco Remy 40SI} Brushless, 12 Volt, 240 Amp Capacity, Pad Mount, with Remote Sense

Vehicle Specifications
2022 HV607 SBA (HV607)

Code	Description
8WDB	BATTERY BOX Steel, with Plastic Cover, 30" Wide, 2-4 Battery Capacity, Mounted Left Side Back of Fuel Tank
8XHD	BATTERY DISCONNECT SWITCH 300 Amp , Disconnects Charging Circuits, Locks with Padlock, Cab Mounted
8MSH	BATTERY SYSTEM {Fleetrite} Maintenance-Free, (4) 12-Volt 2640CCA Total, Top Threaded Stud
8HAE	BODY BUILDER WIRING Rear of Frame ; Includes Sealed Connectors for Tail/Amber Turn/Marker/ Backup/ Accessory Power/Ground and Sealed Connector for Stop/Turn
8XAH	CIRCUIT BREAKERS Manual-Reset (Main Panel) SAE Type III with Trip Indicators, Replaces All Fuses
8WPH	CLEARANCE/MARKER LIGHTS (5) {Truck Lite} Amber LED Lights, Flush Mounted on Cab or Sunshade
8WTR	COURTESY LIGHT (4) Mounted In Front & Rear Map Pocket Left and Right Side
8XHN	HORN, AIR Single Trumpet, Black, with Lanyard Pull Cord
8VAY	HORN, ELECTRIC Disc Style
8630	IGNITION SWITCH Keyless
8WWJ	INDICATOR, LOW COOLANT LEVEL with Audible Alarm
8WBW	JUMP START STUD Remote Mounted
8718	POWER SOURCE Cigar Type Receptacle without Plug and Cord
8RMX	RADIO Omit, Includes Wiring and Antenna
8WNH	RUNNING LIGHT (2) Daytime
8RMS	SPEAKERS Omit
8WTK	STARTING MOTOR {Delco Remy 38MT Type 300} 12 Volt, Less Thermal Over-Crank Protection
8XKM	SWITCH, AIR HORN, PASSENGER Fire Truck Application; Momentary Switch Located in Instrument Panel Close to Passenger, Driver Also To Activate Switch with Lanyard
8WSM	SWITCH, BODY CIRCUITS, MID with Remote Power Module Mounted on Battery Box Back of Cab , Up to 6 Outputs & 6 Inputs Each, Max 20 amp per Channel, Max 80 amp Total, Includes 1 Switch Pack with Momentary Switches
8WSK	SWITCH, BODY CIRCUITS, REAR with Remote Power Module Mounted at Rear on Frame , Up to 6 Outputs & 6 Inputs, Max 20 amp per Channel, Max 80 amp Total, Includes 1 Switch Pack with Momentary Switches
8WPZ	TEST EXTERIOR LIGHTS Pre-Trip Inspection will Cycle all Exterior Lamps Except Back-up Lights
8XGT	TURN SIGNALS, FRONT Includes LED Side Turn Lights Mounted on Fender
8TVN	WIRING MODIFICATIONS for J1939 , with 8' of J1939 250K Body Bus Wiring Coiled Inside Left Rail Behind Transmission, Data High to Pin A, Data Low to Pin B, to Communicate with Pressure Governor

FRONT END

9WBM	FRONT END Tilting, Fiberglass, with Three Piece Construction, Sloped Front
9593	FENDER EXTENSIONS Omit
9HBM	GRILLE Stationary, Chrome
9WBT	GRILLE EMBER SCREEN Mounted to Grille and Cowl Tray to Keep Hot Embers out of Engine and HVAC Air Intake System
9HBN	INSULATION, SPLASH PANELS for Sound Abatement

<u>Code</u>	<u>Description</u>
9HAN	INSULATION, UNDER HOOD for Sound Abatement
9AAB	LOGOS EXTERIOR Model Badges
9AAE	LOGOS EXTERIOR, ENGINE Badges

SPEEDOMETER, TOOLS, MISC

10060	PAINT SCHEMATIC, PT-1 Single Color, Design 100 <u>Includes</u> : PAINT SCHEMATIC ID LETTERS "WL"
10761	PAINT TYPE Base Coat/Clear Coat, 1-2 Tone
10WCY	SAFETY TRIANGLES

FUEL TANKS

15SRE	FUEL TANK Top Draw, Non-Polished Aluminum, D-Style, 19" Tank Depth, 50 US Gal (189L), Mounted Left Side, Under Cab
15WDG	DEF TANK 7 US Gal (26L) Capacity, Frame Mounted Outside Left Rail, Under Cab
15WCS	FUEL COOLER Less Thermostat; Mounted in Front of Cooling Module
15LNS	FUEL/WATER SEPARATOR {Racor 400 Series} 12 VDC Electric Heater, Includes Pre-Heater, with Primer Pump, Includes Water-in-Fuel Sensor, Mounted on Engine

WHEELS, TIRES - FRONT

27DUR	WHEELS, FRONT {Accuride 41730} DISC; 22.5x9.00 Rims, Standard Polish Aluminum, 10-Stud, 285.75mm BC, Hub-Piloted, Flanged Nut, with Steel Hubs
7772540190	(2) TIRE, FRONT 315/80R22.5 Load Range L UNISTEEL G291 (GOODYEAR), 491 rev/mile, 68 MPH, All-Position

WHEELS, TIRES - REAR

28DVP	WHEELS, REAR {Accuride 42644} DUAL DISC; 22.5x8.25 Rims, Extra Polish Aluminum, 10-Stud, 285.75mm BC, Hub-Piloted, Flanged Nut, with Steel Hubs
7382158102	(4) TIRE, REAR 12R22.5 Load Range H G622 RSD (GOODYEAR), 482 rev/mile, 75 MPH, Drive

BODY INTEGRATION

60AAD	BDY INTG, REMOTE POWER MODULE (2) Mounted Under Cab or On Battery Box, Up to 6 Outputs & 6 Inputs Each, Max 20 amp per Channel, Max 80 amp Total; Includes 1 Module with Switch Pack Containing 6 Latched Switches, 1 Module with Hardware Only
60AKK	BDY INTG, HEADLIGHTS, WIG WAG High Beam Wig Wag with Park Brake Interlock, Park Brake Disables Wig Wag
OBD002	MISCELLANEOUS CLEAR FRAME RAILS BOC 6"-42" WITH CLEAN LEFT FRAME RAIL FOR DRIVE SHAFT

Services Section:

WARRANTY

40128	WARRANTY Standard for HV507, HV50B, HV607 Models, Effective with Vehicles Built July 1, 2017 or Later, CTS-2025A
-------	--

**Vehicle Specifications
2022 HV607 SBA (HV607)**

Code

Description

FRONT FENDER EXTENSIONS ADDED AT TSC FOR HV SLOPED HOOD 315R TIRES

VORTEX series Emergency Vehicle

We are Honored to present the following specifications for a Factory New Acres VORTEX series Emergency Vehicle!

Running Boards

There shall be (2) custom embossed aluminum running boards installed on the chassis, (1) unit below both driver & officer-side cab doors. The factory installed running boards shall be removed and replaced with custom fabricated units manufactured with NFPA compliant, skid resistant, embossed aluminum checkerplate. This will hide the painted steel running board brackets and provide an enhanced appearance.

Note: The area below the officer-side crew door shall be fitted with hose reel.

Cab Console

There shall be an aluminum console installed in the cab between the driver and passenger seat. The console shall feature a hinge-up top lid to allow for easy access to interior electrical. A mobile radio, siren control, traffic advisor control & vehicle data recorder control are all components that can be neatly flush-mounted into the hinge-up lid.

On the interior of the console, a 12 volt power supply buss bar shall be installed to allow for hook-up of these item, plus future installations.

The console shall be finished with a speckle coat scratch resistant paint finish.

A Multi-Pin electrical connector shall be included at the front face of the console. This connector allows the console to be removed if engine access is required through the removable cab - engine access panel.

Power Receptacle (Dual USB)

One (1) Dual-USB power receptacle shall be installed at the face of the cab console.

Tablet Holder "Install Only"

A tablet holder device shall be installed to the left of the front officer-seat. The unit shall be supplied by the customer.

Battery Charger

A Kussmaul Chief series, 4012 40amp battery charger shall be installed in the chassis cab beside the console. The charger shall have the following operational specifications:

- * Triple Battery Bank.
- * Built-In Touch Screen Display.
- * Dual Battery Type Technology - allows for two dissimilar battery chemistries charging at the same time.
- * Can Bus enabled connectivity
- * IP32 rated for greater ingress protection
- * Parasitic Load Compensation (PLC) - allows for user input of total accessory load amps on the vehicle. This allows the charger to shift the absorption stage set point, so the battery voltage drops to the float voltage when desired current is reached.
- * Configurable for 3-step or float charging.
- * Optional Remote Touch Display Available.
- * Accommodates Flooded, Gelled Electrolyte, AGM, Odyssey®, Lithium Iron Phosphate (LFP), and customized.
- * Pump Plus (20A Aux) output
- * Rotating mounting feet.

Remote Display

A remote charge display is included to display battery charge level.

Shoreline

A shoreline receptacle shall be installed at the driver-side chassis running-boards. The receptacle shall be wired to the chassis engine start circuit to trigger the auto-eject.

Power Bar, 120vac

A 6-Circuit 120vac power bar shall be installed at the cab console.

Duplex Receptacle

A 120 volt AC duplex receptacle shall be installed beside the cab console and shall be wired to the shore line circuit.

Duplex Recept Comp L2

A 120 volt AC duplex receptacle shall be installed high in compartment L2 and shall be wired to the shore line circuit.

Duplex Recept Comp R2

A 120 volt AC duplex receptacle shall be installed high in compartment R2 and shall be wired to the shore line circuit.

Indicator Lamp

There shall be a Green LED Master-Battery-On lamp installed at the skirt below the driver cab door. The lamp shall illuminate when the mastery battery switch is on.

Air Eject - Auto

There shall be a Kussmaul Automatic Air-Eject receptacle installed on the apparatus. This receptacle shall allow personnel to connect fire hall compressed air supply to maintain apparatus air brake system pressure. The receptacle shall disconnect the air hose automatically, when the engine starter is engaged. A yellow cover shall be included. The air inlet shall be plumbed to a chassis air tank.

Tire Pressure Monitor

There shall be a Real Wheels Tire Pressure Monitor Kit installed on the apparatus. The kit shall include six (6) valve stem pressure sensors, one (1) for each tire. Upon installation, the sensor records the tire pressure and if the pressure drops by 8psi, a Red LED lamp will flash on the sensor to alert and indicate a low tire pressure.

* the kit shall be shipped loose for fire department installation after apparatus is placed in service *

Axle Trim

There shall be Chromed ABS Axle Trim installed on the front & rear axles. The trim shall be single-piece and cover the axle and wheel lugs to provide a pleasing appearance.

Antennas & Mobile Radio(s)

There shall be two (2) mobile radio antenna cables installed on the chassis cab roof. The cables shall be routed to the cab console for hook-up to the mobile radios.

*** Mobile Radio to be supplied by the Fire Department *** OEM to Install Radio ***

Firecom Digital Intercom

There shall be a "Firecom" Intercom system installed. The system shall include a 5100D Digital Intercom, one (1) single channel wireless bases and one (1) UHW-51 under-the-helmet headset.

Headset UHW-51

There shall be one (1) Firecom Wireless Headsets supplied. The Firecom UHW-51 wireless headset with all-in-one design allows complete freedom of movement while maintaining hands-free, full-duplex communication with your crew. Operating with a stand-alone intercom system or integrated with a mobile radio, the flexible design brings all crew members into constant communication. Behind-the-head band configuration with adjustable over-head strap easily accommodates use with helmets. Water-resistant and comfortable ear seals, extended operating temperature, and robust design make this headset ready for action in virtually any fireground environment.

The following features shall apply to the headsets:

- ***1600' line-of-sight range** Over five times the distance and almost 30 times the area of Bluetooth
- ***Completely wireless and antenna-free** No external antennas to break or belt-pack wires to entangle the user
- ***Long-life battery** Operates 24 hours on a 2-hour charge with one-year charge retention, keeps the headset ready for use at all times
- ***PTT radio, Full-duplex intercom** Red push-to-talk over radio button; full-duplex intercom and listen-only radio when button not engaged
- ***Extended-range operating temperature** Rated from -40° to +158°, this headset works wherever you do
- ***DECT6 wireless technology** Crystal-clear, interference-free, and secure communication compared to Bluetooth
- ***Memory foam ComLeather ear seals** Fit comfortably for hours while delivering 24db noise reduction
- ***Three-way adjustable boom** Precise microphone placement, comfort, and performance
- ***Two-year warranty, extendable to 5-year comprehensive service** Extend your two-year standard warranty to five years with the ComCare™ Service Program

Backup Camera

An FRC inView TrueSight Back-UP Camera shall be installed with the following features:

- * one (1) 7" cab monitor
- * one (1) heated back-up camera
- * one (1) hood front center camera

Winch Receiver Front

There shall be a 2" Winch Receiver Tube installed on the front-center of the bumper extension.

Winch Power Cables, Front Bumper

Heavy-Duty Battery Cables shall be routed from the chassis batteries to the front bumper for 12 volt power supply to the winch. The cables shall be placed in loom and properly secured along the chassis frame rails.

Bumper Extension 24" w/ (2) Speed Lays OBM

The chassis front bumper shall be extended 24" forward with 3/8" steel plate channels. The top surface shall be enclosed with polished aluminum checkerplate to provide a pleasing appearance. A re-inforcement structure shall be included to support the bumper sides trailing edges.

Polished Bumper

The bumper shall be fabricated from polished stainless steel, including the left and right bumper trailing edges. The assembly shall be designed to maximize the available usable space for fire service applications.

Speed Lay Compartment

There shall be an aluminum transverse speed-lay compartment installed ahead of the chassis grille with two (2) hose lays to carry 200' of 1.5" hose each. A polished aluminum checkerplate lid shall be attached with stainless steel piano hinge. Rubber door holders are included to support the lid in the open position and a stainless steel latch to secure the lid in the closed position. Two (2) black vinyl tarps shall be attached, one (1) at each side of the speed-lay cover. Bungee cord shall be sown onto the bottom corners to secure the tarps.

RC Monitor OS

The front officer-side of the bumper extension shall allow for a RC Monitor installation.

Bumper Antennas w/ LED

There shall be two (2) stainless steel guide poles mounted at the front corners of the extended bumper. The purpose of the guide poles are to give the driver a visual indication of the location of the front corners of the bumper.

Led Lights

Amber LED lights at the top of each guide pole shall be wired to the truck accessory circuit.

Pump House

The pump house shall be integral to the body at the front. The pump house shall be a fabricated aluminum

sub-structure, fully enclosing the pump assembly. Access panels are located at the top, the driver-side & the officer-side.

Pump Panels

The pump house driver-side & officer-side pump panels shall be 14 guage brushed stainless steel. Rubber sealing washers are positioned over the intake and discharges to retain heat. Stainless steel flanges are placed over top of the sealing washers and fastened in place. The upper portion of both pump panels shall be hinged and latched with 1/4 turn stainless steel latches.

Heat Pan

An aluminum heat pan shall be installed below the pumphouse to close-off for winter heat retention. All four (4) sides of the heat-pan are precision fit to the best of ability as heat retention is of utmost importance. Two (2) removable heat pans shall be installed. One pan shall insert into the heat pan enclosure from each side. Spring pins are used to retain the pans.

Roll-Up Doors, PumpHouse

Roll-Up doors shall be installed to enclose the driver-side and officer-side pump panels.

Air Horn Switch

A push-button air horn switch shall be installed at the pump operators panel to activate the chassis air horn. The button shall be red and marked "Air Horn" with a label.

Heaters Pumphouse

There shall be one (1) Red Dot 35'000btu heater installed in the pumphouse on the left-side, at frame level. Coolant shall be routed through 5/8" thermal hose from the engine for the source of heat. Quarter-turn brass ball valves shall be installed at the engine. This allows the user to close the circuits if required. The activation switch shall be at the cab dash within convenient reach of the operator.

Heat Exchanger Engine

There shall be a stainless steel stacked plate heat exchanger installed in the pumphouse compartment to assist in cooling the engine in hot climates. This heat exchanger shall be spliced into the pumphouse heater coolant supply/return lines. A 3-way valve shall be installed at the heat exchanger.

With the 3-way valve in the summer position, the hot coolant shall bypass the pumphouse heaters and flow through the heat exchanger and back to engine. Placing the 3-way valve in the winter position, bypasses the heat exchanger and allows hot coolant to flow through the pumphouse heaters and back to engine.

A quarter-turn brass valve shall be installed at the pump operators panel. Water from the fire pump discharge manifold shall be piped to this valve and on to the heat exchanger. A water strainer shall be installed to strain the cooling water before it enters the heat exchanger. A flush line shall be piped from the dirty side of the strainer to the pumphouse side panel with a 3/4" lift handle style brass ball valve. The pump operator can periodically open this valve to flush the strainer.

The cooling water valve shall be labeled Engine Cooler, and the flush valve Cooling Water Flush.

Engine Cooler

There shall be an engine cooler water supply circuit installed. A 1/4-turn valve shall be installed at the pump operators panel. Water supply shall be taken from the pump discharge manifold, plumbed through this valve and routed to the inlet of the engine heat exchanger. An inlet strainer shall strain the water before it enters the heat exchanger. This cooling water shall then be routed back to the booster tank.

Pump Cooler

There shall be a pump cooler circuit installed. A 1/4-turn valve shall be installed at the pump operators panel. Opening this valve allows water to flow from the discharge side of the pump manifold to the booster tank.

Waterous Fire Pump

There shall be a Waterous Model CSPA (1250 US GPM) Single Stage PTO Fire Pump installed.

PUMP

The pump shall be of single stage construction and shall comply with all applicable requirements of the latest standards for automotive fire apparatus of the National Fire Protection Association, NFPA 1901-2016, and shall have a rated capacity of 1250 US-GPM (1050 Imp Gal). The Pump shall be free from objectionable pulsation and vibration under all normal operating conditions.

PUMP BODY

The pump body shall be close-grained, gray iron and must be horizontally split in two sections for easy removal of the entire impeller shaft assembly, and designed for complete servicing from the bottom of the truck without disturbing setting of the pump in the chassis or apparatus piping which is connected to the pump. Pump body halves shall be bolted together on a single horizontal face to minimize leakage and facilitate reassembly.

DISCHARGE MANIFOLD

The discharge manifold shall be cast as an integral part of the pump body assembly and shall provide at least three full 3-1/2 inch openings for ultimate flexibility in providing various discharge outlets for maximum efficiency, and shall be located as follows:

- One outlet on the right side of the pump body
- One outlet on the left side of the pump body
- One outlet directly on top of the pump discharge manifold

IMPELLAR

The impeller shall be bronze with double suction inlets, accurately balanced (mechanically and hydraulically), labyrinth type, wear rings that resist water bypass and loss of efficiency due to wear.

WEAR RINGS

The wear rings shall be bronze, and shall be easily replaceable to restore original pump efficiency and eliminate the need for replacing the entire pump casing due to wear.

IMPELLER SHAFT

The impeller shaft shall be stainless steel, accurately ground to size. The impeller shaft shall be of two-piece construction separable between the pump and pump transmission to allow true separation of the transmission from the pump without disassembly of either component.

ANTI-FRICTION BEARINGS

The impeller shaft shall be supported at each end by oil or grease lubricated anti-friction ball bearings for rigid and precise support. Bearings shall be protected from water and sediment by suitable seal housings, flinger rings, and oil seals. No sleeve type bearings shall be used.

PUMP TRANSMISSION

The pump transmission shall be rigidly attached to the pump body assembly and be of latest design incorporating a high strength, involute tooth form Morse™ HV chain drive capable of operating at high speeds to provide smooth, quiet transfer of power.

Chelsae PTO

There shall be a Chelsae "Hot-Shift" Power-Take-Off installed on the left-side of the chassis transmission. This PTO shall power the fire pump and can be used for both stationary and pump-and-roll applications. The PTO shall be pressure lubricated with synthetic oil from the chassis Allison automatic transmission.

Coupler Shaft (A)

There shall be a 1410 Series Drive-Shaft Coupler-Shaft installed. One end shall be connected to the Chelsae PTO with a companion flange. The other end shall include a yoke and hanger bearing with a mounting bracket attached to the chassis frame rail. The hanger bearing shall include a rubber bushing to absorb drive line vibrations. The drive-shaft assembly shall be precision balanced prior to installation.

Coupler Shaft (B)

There shall be an intermediate 1410 Series Drive-Shaft Coupler-Shaft installed. One end shall be connected to the first coupler shaft. The other end shall include a yoke and hanger bearing with a mounting bracket attached

to the chassis frame rail. The drive-shaft assembly shall be precision balanced prior to installation.

Slip Shaft

There shall be a 1410 Series Drive-Shaft Slip-Shaft installed. One end shall be connected to the coupler-shaft. The other end shall include a slip-yoke, attached to the fire pump. The drive-shaft assembly shall be machine balanced prior to installation.

Fire Pump Frame

The fire pump frame shall be manufactured from 3/8" mild steel plate. Angles shall be bolted to both chassis frame rails with grade 8 bolts. These angles shall have flanges formed for the pump frame channels to bolt onto. Four (4) Rubber Vibration Isolation Mounts shall be installed between the pump frame and chassis frames to assist in reducing driveline & pump vibration. All frame components shall be painted with a rust prevention coating.

Pump Seal

There shall be a mechanical spring-loaded pump seal installed on the fire pump.

Pump Overheat Protection

There shall be a pump overheat protection system installed. The system shall include a thermal valve at the pump discharge manifold that opens automatically when the water temperature reaches 140 degrees F and dumps to atmosphere. An LED lamp shall be installed at the pump operators panel that flashes once the water temperature reaches 180 degrees F. A push-button switch shall be included to test the lamp function.

Fire Pump Engage Switch (Cab)

There shall be a pump-engage switch installed at the chassis dash to engage the Fire Pump Power-Take-Off.

* shall require the engine to be at idle to function *

Fire Pump Engage Switch (Pump-House)

There shall be an additional fire pump engage switch installed at the pump operators control panel. This allows the pump operator to open the tank-to-pump valve to flood the fire pump prior to engaging the fire pump. It also allows for shutting-down the fire pump without having to climb into the chassis cab.

* shall require the engine to be at idle, the transmission to be in neutral and the park brake to be engaged to function *

Primer AirPrime

A Trident AirPrime pump primer shall be installed. The system shall utilize chassis air pressure to prime the fire pump through a ventura. An Auto-Prime feature is included that will sense pump discharge pressure and automatically re-prime fire pump as pressure drops.

Remote Prime

A remote prime option shall be included to allow the operator to prime to the following locations:

- * Main Pump Body
- * Driver-Side Intake
- * Officer-Side Intake
- * Rear Intake

Each remote prime option shall include an individual primer control.

6" Intake Bleeders

There shall be Intake Bleeder valves installed for the following intakes, to bleed air from the intakes when receiving water supply from a positive pressure supply source, when the valve are closed.

- * the Driver-Side 6" intake
- * the Officer-Side 6" intake
- * the Rear Intake

Foam Proportioner

There shall be a Waterous Aquis 3.0 Electronic Foam Proportioner installed, with the following features:

Control Box:

Microprocessor Controller:

A 16-bit mixed signal microcontroller with a 60 kB flash memory, 2kB RAM and 12-bit analog to digital convertor. Receives flowmeter flow rate and operator specifications through the OIT and provides the necessary voltage to the pump motor driver.

Pump Motor Driver:

Receives signals from the microprocessor controller and powers the electric motor in a variable speed duty cycle to ensure the correct amount of foam concentrate set by the operator is injected into the water stream.

Operator Interface Terminal

The Operator Interface Terminal (OIT), mounted on the pump operator's panel allows the operator to perform the following functions:

- * Push button control of foam proportioning rates:
 - * Class A concentrate: .1% to 1% in increments of .1%
 - * Class B concentrate: 1%, 3% or 6% Calibration of water flow rate.
- * Adjustable units of measurement.
- * Simulated water flow.
- * Optional lockout.
- * Warning of low foam concentrate supply:
 - * Flashes and the displays a steady "low concentrate" warning when the concentrate tank runs low. Note that system will shut down after two minutes.
 - * Flashes a "no concentrate" warning when the concentrate tank is empty. Warning of an electronic malfunction: Flashes and "error" warning when the concentrate tank is empty. If apparatus has dual foam concentrate tanks, allows selection of tank A or B and displays which tank is in use. Operation in manual mode as a backup. A separate panel plate with operation instructions is furnished.

Flowmeter

A paddlewheel-type flowmeter, installed in the process manifold upstream of the foam injection point, connects to the microcontroller. A flowmeter tee, constructed of brass with Victaulic groove outer connections and threaded NPT inner connections at each end of the tee, is provided for connection to the apparatus plumbing.

Foam Pump

Consists of an electric motor, positive displacement triplex plunger pump and control box mounted on a bracket.

Electric Motor: 1/2 HP (.4 kW) 12 or 24 volt. Protected with an electrical load circuit breaker of 80 amps for 12 VDC and 50 amps for 24 VDC.

Pump Rating: 3.0 GPM @ 150 psi (11.5 L/min @ 10 bar) with intermittent operating pressures up to 450 psi (31 bar).

Pump Construction: Equipped with an anodized aluminum crankcase, oversized ball bearings, forged brass pump body and manifold, solid ceramic plungers, stainless steel inlet and delivery valves and piston guides. Buna packing and preset pressure regulating valve.

Control Cables and Connectors

Separate industry standard M12 connectors for connection of OIT and flowmeter to foam pump control box.

Consists of shielded cables to prevent radio frequency or electro-mechanical interference. Furnished as follows:

OIT connection to control box: 6 meters long
Flowmeter connection to control box: 3 meters long
Foam concentrate tank level switch to foam pump control box: 4 meters long

Low Tank Level Switch

A low tank level float switch, installed in the foam concentrate tank and connected to the control unit, alerts the operator to low foam supply conditions.

Foam System Support

The AQUIS is equipped with a USB interface for PC-connectivity which allows a qualified technician to perform upgrades, diagnostics and monitor system functions in real time. The system can also be remotely monitored

through the USB interface using any PC with internet access, allowing technicians to easily connect to the Waterous dedicated website to assure proper operation and to update the foam system hardware by uploading new features and functions as they become available.

Intake 6" Driver-Side (Gated-Elec)

There shall be a 6" M NH intake installed on the left-side of the fire pump. The intake shall include an electric butterfly valve, installed inside the pumphouse. This keeps the valve in a warm winter-time environment and removes the traditional bulk of a piston-intake-valve from the out-side. The valve controller is installed at the pump operator control panel.

A waterous non-pilot type intake relief valve shall be installed.

A 3/4" lift-style drain valve shall be included.

The intake and drain valve shall be labelled to indicate their function. The label shall be color-coded burgundy.

Intake 6" Officer-Side (Gated-Elec) w Rr Int Opt

There shall be a 6" M NH intake installed on the right-side of the fire pump. The intake shall include an electric butterfly valve, installed inside the pumphouse. This keeps the valve in a warm winter-time environment and removes the traditional bulk of a piston-intake-valve from the out-side. The valve controller is installed at the pump operator control panel. The intake shall include an option for installation of a rear of apparatus pump intake.

A waterous non-pilot type intake relief valve shall be installed.

A 3/4" lift-style drain valve shall be included.

The intake and drain valve shall be labelled to indicate their function. The label shall be color-coded burgundy.

Intake 6" Rear-Body-Right (Gated)

There shall be a 6.0" Aux Pump Intake installed, plumbed with 6.0" stainless pipe through the poly tank to the back of the body right-side. All plumbing shall be stainless steel. A Waterous Jamesbury Electric Butterfly Valve is included, installed inside the pumphouse. The valve controller shall be installed at the pump operator control panel.

A waterous non-pilot type intake relief valve shall be installed.

A 3/4" lift-type bleeder/drain valve shall be installed at the pump operators panel. Installed on the inlet at the back of the body is a 6.0" NH adapter w/ strainer and chromed cap. Color coded labels shall be included.

Intake 2.5" #1 Aux Left-Front

There shall be a 2.5" Auxiliary Intake installed at the left-side pump panel ahead of the Main Intake. An Akron Brass ball valve with composite ball and remote valve actuator shall be included. The valve actuator shall be a direct mount lever located beside the valve. The intake shall include a 2.5" female swivel adapter and chromed plug, chained to the pump panel. A strainer shall be included. The threads shall be CSA.

A 3/4" lift-style bleeder/drain valve shall be installed on the intake. The intake and drain valve shall be labeled with a color-coded label.

Intake 2.5" #2 Aux Right-Front

There shall be a 2.5" Auxiliary Intake installed at the right-side pump panel ahead of the Main Intake. An Akron Brass ball valve with composite ball and remote valve actuator shall be included. The valve actuator shall be a direct mount lever located beside the valve. The intake shall include a 2.5" female swivel adapter and chromed plug, chained to the pump panel. A strainer shall be included. The threads shall be CSA.

A 3/4" lift-style bleeder/drain valve shall be installed on the intake. The intake and drain valve shall be labeled with a color-coded label.

Intake - Tank to Pump (Dual Elec Ctrl)

There shall be a 3.5" stainless steel tank-to-pump supply line installed. An Akron Brass 3.0" Ball Valve with composite ball and KZCO Electric Valve Actuator shall be included.

Two (2) Electric Valve Switches shall be installed at the following locations:

- * one (1) at the pump operator panel
- * one (1) at the cab console next to the driver

Color-coded labels shall be provided.

Tank Fill Line

There shall be a 2.0" tank fill line installed. An Akron Brass 2.0" Ball Valve with composite ball and remote valve actuator shall be included. The valve actuator shall be a positive locking t-handled lever at the pump operator panel. The lever shall be labeled with a color-coded label. High-Pressure flexible hose shall be used to route the line from valve to tank. Stainless steel fittings are crimped to the end of hose.

Discharge Manifold

There shall be a Waterous Cast Iron Discharge Manifold assembly installed on the fire pump. The manifold shall feature numerous discharge port options to facilitate multiple discharge plumbing/routing options.

Discharge 2.5" #1 Left-Front

There shall be a 2.5" Discharge located on the left-side of the pump-house towards the front. An Akron Brass 2.5" ball valve with composite ball and remote valve actuator shall be included. The valve actuator shall be a positive locking t-handled lever at the pump operator panel. A push-pull cable shall be installed between the valve lever and the valve. The discharge shall include a 30 degree droop and chromed cap, chained to the pump panel. The threads shall be CSA.

There shall be a 2.5" stainless steel dual-scale Psi/Kpa discharge pressure gauge installed for this discharge.

A 3/4" - lift-style bleeder/drain valve shall be installed for the discharge at the base of the pump panel. The valve lever and drain valve shall be labeled with a color-coded label.

Discharge 2.5" #2 Left-Rear

There shall be a 2.5" Discharge located on the left-side of the pump-house towards the rear. An Akron Brass 2.5" ball valve with composite ball and remote valve actuator shall be included. The valve actuator shall be a positive locking t-handled lever at the pump operator panel. The discharge shall include a 30 degree droop and chromed cap, chained to the pump panel. The threads shall be CSA.

There shall be a 2.5" stainless steel dual-scale Psi/Kpa discharge pressure gauge installed for this discharge.

A 3/4" - lift-style bleeder/drain valve shall be installed for the discharge at the base of the pump panel. The valve lever and drain valve shall be labeled with a color-coded label.

Discharge 2.5" #3 Right-Front

There shall be a 2.5" Discharge located on the right-side of the pump-house towards the front. An Akron Brass 2.5" Ball Valve with composite ball and remote valve actuator shall be included. The valve actuator shall be a positive locking t-handled lever at the pump operator panel. The discharge shall include a 30 degree droop and chromed cap, chained to the pump panel. The threads shall be CSA.

There shall be a 2.5" stainless steel dual-scale Psi/Kpa discharge pressure gauge installed for this discharge.

A 3/4" - lift-style bleeder/drain valve shall be installed for the discharge at the base of the pump panel. The valve lever and drain valve shall be labeled with a color-coded label.

Discharge 4.0" #4 Right-Rear

There shall be a 4.0" discharge located on the right-side of the pump-house towards the rear. An Akron Brass 3.0" 8900 series Ball Valve with composite ball and remote valve actuator shall be included. The valve actuator shall be a rotary hand-wheel style at the pump operator panel. The discharge shall include a 30 degree x 4.0" storz droop and storz cap, chained to the pump panel.

There shall be a 2.5" stainless steel dual-scale Psi/Kpa discharge pressure gauge installed for this discharge.

A 3/4" - lift style bleeder/drain valve shall be installed for the discharge at the base of the pump panel. The valve lever and drain valve shall be labeled with a color-coded label.

Discharge 2.5" #5 Hose-Bed Pre-Con

There shall be a 2.5" pre-connect discharge located on the left-front of the hose-bed. An Akron Brass 2.5" ball valve with composite ball and remote valve actuator shall be included. The valve actuator shall be a positive locking t-handled lever at the pump operator panel.

There shall be a 2.5" stainless steel dual-scale Psi/Kpa discharge pressure gauge installed for this discharge.

A 3/4" - lift style bleeder/drain valve shall be installed for the discharge at the base of the pump panel. The discharge and drain valve shall be labeled with a Green color-coded label. The threads shall be CSA.

Discharge 2.5" #6 Hose-Bed Pre-Con (Foam)

There shall be a 2.5" pre-connect discharge located on the right-front of the hose-bed. An Akron Brass 2.5" ball valve with composite ball and remote valve actuator shall be included. The valve actuator shall be a positive locking t-handled lever at the pump operator panel.

There shall be a 2.5" stainless steel dual-scale Psi/Kpa discharge pressure gauge installed for this discharge.

A 3/4" - lift style bleeder/drain valve shall be installed for the discharge at the base of the pump panel. The discharge and drain valve shall be labeled with a Green color-coded label. The threads shall be CSA. **Shall be foam capable.**

Foam Manifold (A)

There shall be a 2.5" stainless steel foam manifold (A) installed. An Elkhart Brass check valve shall be included to prevent foam solution to back flow to the clean water manifold. A 3/8" brass drain valve shall be installed at the lower pump panel to drain the foam manifold. The drain valve shall be labeled Foam Manifold Drain.

Foam Manifold (B)

The foam distribution manifold shall include the following discharges:

- * four (4) 2.0" discharges
- * one (1) 2.5" discharge

Speedlay #1 Foam, Front Bumper

There shall be a 1.5" F NPSH speedlay hose-bed installed transvers at the front extended bumper as speed-lay #1. An Akron Brass 2.0" ball valve with composite ball and remote valve actuator shall be included. The valve actuator shall be a positive locking t-handled lever at the pump operator panel, with push-pull cable. High-Pressure flexible 2.0" hose with stainless steel crimped end fittings shall be used to route the discharge from valve to hose-bed.

There shall be a 2.5" stainless steel dual-scale Psi/Kpa discharge pressure gauge installed for this discharge.

A 3/4" - lift style bleeder/drain valve shall be installed for the discharge at the base of the pump panel. The intake and drain valve shall be labeled with an Orange color-coded label. **This discharge shall be foam capable.**

Speedlay #2 Foam, Front Bumper

There shall be a 1.5" F NPSH speedlay hose-bed installed transvers at the front extended bumper as speed-lay #2. An Akron Brass 2.0" ball valve with composite ball and remote valve actuator shall be included. The valve actuator shall be a positive locking t-handled lever at the pump operator panel, with push-pull cable. High-Pressure flexible 2.0" hose with stainless steel crimped end fittings shall be used to route the discharge from valve to hose-bed.

There shall be a 2.5" stainless steel dual-scale Psi/Kpa discharge pressure gauge installed for this discharge.

A 3/4" - lift style bleeder/drain valve shall be installed for the discharge at the base of the pump panel. The intake and drain valve shall be labeled with an Orange color-coded label. **This discharge shall be foam capable.**

Plumbing Front Bumper Monitor

There shall be plumbing installed and routed to the front bumper for installation of a remote controlled monitor. The plumbing shall be a combination of 2.0" stainless piping and high-pressure flexible hose with crimped stainless steel end fittings. The hose shall be secured along the under-side of the chassis next to the chassis frame rails.

An auto-drain valve shall be installed at the lowest point to automatically open and drain the piping when pressure drops below 8psi. ***This discharge shall be Foam Capable.***

Monitor TFT Front Bumper

A Task Force Tips Tornado model # Y2-E88A electric remote controlled monitor shall be installed. The monitor shall be controlled by a monitor mounted membrane switch panel with functions that control rotation, elevation and nozzle patterns, oscillate, park, auxiliary 1 and auxiliary 2.

The monitor shall have the following travel capabilities: full horizontal rotation with travel 185 degrees left and right of center, full 135 degrees of vertical travel with field changeable vertical stops at 45 degrees above and 20 degrees below horizontal, field changeable rotation stops shall be provided 90 degrees left and right of center, flow capability of 500 GPM with no more than 25 PSI loss, maximum operating pressure of 200 PSI.

The electrical components for the monitor shall be waterproof and utilize current limiting and position encoders to protect the drive train at the ends of travel. Monitor shall have waterproof plug for power and control cable connection for easy removal. An electrical connection for a TFT remote control nozzle shall be provided. The monitor shall be equipped with manual override knobs for use in the event of power failure.

For resistance to corrosion the monitor shall be constructed from hardcoat anodized aluminum with a silver powder coat interior and exterior finish.

The monitor shall be configured with a 2" female NPT inlet with quick disconnect with locking pin and 1-1/2" male NH outlet. The unit shall be covered by a five-year warranty.

Monitor Joystick

A Task Force Tips model # Y4E-JS-GT joystick style control station for Task Force Tips Tornado series remote control monitor shall be installed. The joystick shall be mounted in an enclosure and control horizontal rotation, vertical elevation and nozzle stream pattern and have a momentary trigger button that can control an optional Task Force Tips valve with interface box by squeezing if desired. The monitor speed is proportional to the joystick movement. A sliding switch shall allow for flow control by adjusting the Task Force Tips gateable valve operation. The control requires 12 or 24 volt DC power.

The enclosure shall include membrane switches and LED lights to program and control programmable park and oscillate functions, and a toggle switch to control an optional Task Force Tips valve with interface box. Two additional membrane switches are included to control optional, auxiliary equipment such as a light. LED lights show gateable valve status and operation. A ten foot long, four-conductor cable with four-pin plug to connect to the optional valve interface box shall exit the enclosure.

The joystick enclosure box shall include a circuit board to communicate with the Task Force Tips remote control monitor and optional valve interface. Internally mounted switches shall be included for the ability to choose which control station shall be dominant where additional controls are used, and to retain oscillate programming if desired. All joystick components and circuitry are mounted to the top portion of the enclosure and can be removed for console mounting. A storage bracket for the handheld control shall be included and shall comply with NFPA 1901 Section 14.1.11. The unit shall be covered by a five-year warranty.

Monitor Nozzle

A Task Force Tips Ultimatic 125, model # B-TO-ERP-120 automatic nozzle with electrically operated pattern control shall be provided. The nozzle design shall allow for straight stream through dense wide fog patterns and be able to be flushed without shutting down.

The electric drive unit shall develop over 400 pounds of torque, be enclosed in a waterproof cast aluminum housing and include a manual override device in the event the power source fails. The unit shall be compatible with 12 or 24 volt power systems and require no more than a 3 amp power draw and include a 6" connection cable with plug.

Nozzle stream shaper actuator shall have position encoder for smooth transition between straight stream and fog pattern with fine stream adjustment. Nozzle stream shaper shall stop and pause at full fog position. A second electrical actuation of the stream shaper shall move the shaper to the flush position for removing debris from the nozzle.

For corrosion resistance and durability the nozzle shall be constructed from hardcoat anodized aluminum alloy, a protective rubber bumper with fog teeth, laser engraved serial number, reflective labeling and five year warranty.

The nozzle shall have a 1-1/2" female NH swivel rocker lug coupling and a flow range of 10-125 GPM at 120 PSI. A waterproof six-pin electrical connection for use with TFT remote control monitors shall be included. The nozzle shall be designed to accept the TFT FJ-U or FJ-UMX FoamJet low expansion air aspirating attachments.

Monitor Electric Valve

A Task Force Tips electric gateable valve kit for Tornado series remote control monitors shall be installed. The valve package shall include an akron valve with controller mounted on valve, and an interface box for connection of joystick control, monitor and power. The valve kit electrical components shall be compatible with 12 or 24 volt direct current.

The enclosure shall be weatherproof and utilize weatherproof components such as a silicone seal, hardware with o-rings and liquid tight electrical connections with strain relief fittings.

The enclosure shall include the following: A preconnected 20 foot, four-conductor cable with waterproof, four-pin connection plug for power and communications connection to the monitor; A preconnected 20 foot, six-conductor cable with waterproof, six-pin connection plug for connection to valve controller; A preconnected 15 foot, two conductor cable with stripped ends for connection to vehicle power; A four-pin receptacle with cap for connection to joystick control; An unused strain relief fitting for an additional operator station cable.

The valve shall have 2" NPT female inlet and outlet, stainless steel ball and housing, valve position indicator, and six-conductor cable with waterproof plug for connection to enclosure valve control cable. The valve kit shall be covered by a written five-year warranty.

** The Monitor shall be installed on the front center of the bumper **

Plumbing, Hose Reel

There shall be a discharge installed for one (1) hose reel supply at the officer-side running boards. A KZCO 1.5" stainless steel valve with electric actuator shall be included. The valve switch shall be located at the pump operators panel.

A 3/4" - lift style bleeder/drain valve shall be installed at the base of the pump panel. The discharge and drain valve shall be labeled with a color-coded label. **This discharge shall be foam capable.**

Hose Reel (Officer-Side)

There shall be one (1) 1.0" Hannay Hose Reel supplied and installed beneath the cab on the officer-side rear of the crew-cab chassis, behind the running boards. The reel shall be equipped with 12v electric rewind. A hose roller guide shall be installed. The reel shall be powder coated Red.

Hose for Hose Reel

There shall be 100' of 1.0" rubber discharge hose installed on the hosereel. The hose shall be yellow in colour

and rated at 300psi.

Nozzle Wildlands

One (1) Akron Brass model #1602 1.0" ProVenger Nozzle shall be provided. The 1" ProVenger SG fire hose nozzle is the selectable gallonage style for the ProVenger Series Nozzles. ProVenger SG is a constant gallonage (flow remains the same in all patterns) with various flow setting for frontline flow control. ProVenger SG is an unbeatable value with the performance that you demand.

Low flow options, starting at 5 gpm (19 lpm), are available within the 1" (25 mm) ProVenger line. The new, lower flows aid firefighters in regulating the amount of water needed to extinguish various fires. The 1" nozzles are perfect for wildland and gas cooling applications. Find an Akron Brass distributor near you to learn more about this fire hose nozzle.

Hose Line Blow-Outs

There shall be an air blown-out line plumbed to the foam manifold to remove standing water from all foam capable hose lines. Injecting compressed air to the manifold will evacuate the water from hose lines to prevent freezing.

A quarter-turn valve shall be installed at the face of the pumphouse. The air source shall be plumbed from the chassis air tanks, through a pressure protection valve that closes the supply line when air drops below 70 psi.

Electrical System

An electrical power distribution system shall be installed. The switch panel shall be located in the cab convenient to the operator. Remote power modules are installed in strategic locations on the apparatus to reduce wiring harness requirements.

Power Distribution Panel

All body electrical equipment installed by the apparatus manufacturer shall conform to current automotive electrical system standard, the latest Federal DOT standards, and the requirements of the applicable NFPA Apparatus Standard. Twisted pair shielded wire shall be provided within the electrical system for noise reduction.

The wiring harness shall conform to SAE J-1128 with SXL temperature properties. All exposed wiring shall be run in loom with a minimum 200 degree Fahrenheit rating. All wiring looms shall be properly supported and attached to body members along the entire run. All wiring shall be mounted so as to provide protection from water and heat. All connections shall be crimp type with heat shrink tubing with insulated shanks to resist moisture and foreign debris such as grease and road grime. Weather-resistant connectors shall be provided throughout to ensure the integrity of the electrical system. All wiring looms shall be properly supported and attached along the entire run. At any point where wire or looms must pass through metal, rubber grommets shall be installed to protect the wire from abrasion.

All wiring shall be individually coded every 2" on the insulation to allow for easy identification. The numbering shall be continuous, along the entire length of the harness.

The main low voltage chassis to body interface point and distribution panel shall be provided at the rear of the body in a location providing easy service access. The distribution panel shall be labeled and shall contain the body electrical power distribution equipment. The distribution panel shall be located so as not to reduce useable compartment space. An electrical harness quick-disconnect shall be provided to facilitate easy removal of the body, should such a procedure become necessary.

Pressure Governor and Engine Monitoring Display

A Fire Research PumpBoss series PBA401-A00 pressure governor and monitoring display kit shall be installed. The kit shall include a control module, intake pressure sensor, discharge pressure sensor, and cables. The control module case shall be waterproof and have dimensions not to exceed 6 3/4" high by 4 5/8". The control knob shall be 2" in diameter with no mechanical stops, have a serrated grip, and a red idle push button in the center. It shall not extend more than 1 3/4" from the front of the control module. Inputs for monitored engine information shall be from a J1939 databus or independent sensors. Outputs for engine control shall be on the J1939 databus or engine specific wiring. Inputs from the pump discharge and intake pressure sensors shall be electrical.

The following continuous displays shall be provided:

- Engine RPM; shown with four daylight bright LED digits more than 1/2" high
- Check engine and stop engine warning LEDs
- Engine oil pressure; shown on a dual color (green/red) LED bar graph display
- Engine coolant temperature; shown on a dual color (green/red) LED bar graph display
- Transmission Temperature: shown on a dual color (green/red) LED bar graph display
- Battery voltage; shown on a dual color (green/red) LED bar graph display
- Pressure and RPM operating mode LEDs
- Pressure / RPM setting; shown on a dot matrix message display
- Throttle ready LED.

A dot-matrix message display shall show diagnostic and warning messages as they occur. It shall show monitored apparatus information, stored data, and program options when selected by the operator. All LED intensity shall be automatically adjusted for day and night time operation.

The program shall store the accumulated operating hours for the pump and engine to be displayed with the push of a button. It shall monitor inputs and support audible and visual warning alarms for the following conditions:

- High Battery Voltage
- Low Battery Voltage (Engine Off)
- Low Battery Voltage (Engine Running)
- High Transmission Temperature
- Low Engine Oil Pressure
- High Engine Coolant Temperature
- Out of Water (visual alarm only)
- No Engine Response (visual alarm only).

The program features shall be accessed via push buttons located on the front of the control module. There shall be a USB port located at the rear of the control module to upload future firmware enhancements.

The governor shall operate in two control modes, pressure and RPM. No discharge pressure or engine RPM variation shall occur when switching between modes. A throttle ready LED shall light when the interlock signal is recognized. The governor shall start in pressure mode and set the engine RPM to idle. In pressure mode the governor shall automatically regulate the discharge pressure at the level set by the operator. In RPM mode the governor shall maintain the engine RPM at the level set by the operator except in the event of a discharge pressure increase. The governor shall limit a discharge pressure increase in RPM mode to a maximum of 30 psi. Other safety features shall include recognition of no water conditions with an automatic programmed response and a push button to return the engine to idle.

The pressure governor and monitoring pressure display shall be programmed at installation for a Cummins Engine.

Water Tank Level

An Innovative Controls Soft-Glo Series Water Tank Level Monitor System shall be installed.

The display modules shall each receive an input signal from a dedicated pressure transducer. These stainless steel sender units shall be installed on the outside of the water tank near the bottom. All wiring, cables and connectors shall be waterproof without the need for sealing grease.

Water Tank Level Lights (Remote)

There shall be two (2) LED Remote Water Tank Level Lights installed. The lights shall be driven by the master water tank level display located at the pump operators panel.

The lights shall be installed in the following locations:

- * one (1) at the left-side of the apparatus body at the front-upper
- * one (1) at the right-side of the apparatus body at the front-upper

Foam Tank Level

An Innovative Controls Soft-Glo Series Foam Tank Level Monitor System shall be installed.

The display modules shall each receive an input signal from a dedicated pressure transducer. These stainless steel sender units shall be installed on the outside of the water tank near the bottom. All wiring, cables and connectors shall be waterproof without the need for sealing grease.

Master Gauges & Test Ports

There shall be one (1) Master Vacuum and one (1) Master Pressure gauge assembly installed at the pump operators panel. The gauges shall be stainless steel, 4" diameter. The vacuum gauge shall have a scale of -30 to 400 psi (0-2750 kpa). The pressure gauge shall have a scale of 0-400 psi (0-2750 kpa). Two (2) pump test ports shall be included. The gauges and the test ports shall be part of a chromed bezel for a pleasing appearance.

Master Drain Valve

There shall be a Master Pump Drain Valve installed at the base of the driver-side pump panel. The valve shall be Trident Brand, 10-port rotary type with a single-point drain.

Water/Foam Tank Poly

An 800 Imp-Gal poly water tank shall be installed. The tank shall be NFPA compliant, manufactured by UPF (United Plastic Fabricating).

* A 6-bolt flange shall be welded at the driver-side rear wall for a 2.5" firemans friend valve installation *

Foam Tank, Poly

A 25 Imp-Gal poly foam tank shall be installed. The tank shall at the front-right corner, integral to the water tank.

Direct-Tank-Fill 4" (1)

There shall be one (1) 4" Stainless Steel Direct-Tank-Fill Valve installed at the back of the poly tank. The valve shall include a spring-loaded plunger that opens automatically when pressure is applied, and closes automatically when pressure falls below 8psi. A 1/4-turn bleeder valve is included with a 30 degree x 4" Storz droop adapter and storz cap.

* The location shall be on the Rear, Officer-Side of the apparatus *

Drain Valve Water Tank

A 1.5" brass gate valve shall be installed at the base of the tank for the tank drain.

Body Sub-Frame

The subframe shall consist of aluminum structural square tubing and aluminum structural rectangular tubing. Tubing's shall be positioned above the chassis frame rails, running full length from front to back. Square tubing's shall extend outwards into the wheel well openings, in front of and behind the chassis rear wheels. These crossmembers shall then be connected to the floor braces of the wheel well compartment floors with vertical structural members. This design shall transfer body loads directly to chassis frame via the aluminum structure instead of welded joints resulting in exceptional strength.

Rectangular tubing's shall extend full width from side to side at the front and the back of the body. The body compartments shall receive cut-outs, through which these structural tubing's shall insert, again resulting in body loads being transferred to the sub-frame via structure instead of welded joints.

All other crossmembers shall be rectangular tubing, welded rigidly to provide a high strength base for proper support of the poly water tank.

The alloy shall be 6061-T6 and shall be welded by CWB (Canadian Welding Bureau) certified welders using the semi-automatic mig welding process. The sub - structure shall be re-enforced with gussets in high stress areas. The sub-frame design shall include sufficient crossmembers to ensure adequate water tank support.

Body Aluminum - High-Side/High-Side

The aluminum body shall be an Extruded Aluminum Body, consisting of proprietary aluminum extruded profiles. These aluminum profiles shall be produced from 6061 series aluminum alloy and shall be of sufficient strength to carry the weight of the body & equipment. The extrusions shall transfer the body & equipment weights to the under-body sub-frame, which shall transfer directly to the chassis frame. This design eliminates any of the compartment walls from functioning as load-bearing members, which could result in body cracking.

All extrusion joints shall be properly prepared/beveled in advance of the welding process. All welding shall be performed by CWB certified welders.

The aluminum material shall be (3/16") 5052 (marine grade) providing enhanced resistance to corrosion and high weld joint efficiencies. The body shall be computer modeled before construction ensuring correct configuration and geometry. After modeling, the sheet-metal parts shall be flattened (electronically) and produced on CNC sheet metal cutting equipment. This will ensure extremely high part tolerances resulting in excellent fit/finishes. Compartment floors shall receive tabs which when assembled, will insert into grooves cut into the compartment side walls. Tab and groove construction removes a high portion of stress loads from welded joints.

Tab and Groove construction also eliminates double wall joints which can trap moisture and encourage corrosion. To prevent (oil canning) all compartment floors shall be re-enforced with a minimum of two (2) structural re-enforcements. All floors shall be of the sweep-out design allowing easy cleaning.

Body to Chassis Frame Attachment

The aluminum body shall be fastened to the chassis frame with custom body mounts. This attachment design also allows for easy body removal should such a procedure become necessary.

Rubber Isolator (Frame to Body)

A full length/width of ¼" neoprene rubber shall be bonded to the chassis frame before the body is installed. This shall serve as an isolator for dissimilar metals.

Body Compartments Driver-Side

L1

This compartment shall house the driver-side pump operators panel.

L2

There shall be one (1) compartment on the left side ahead of the rear wheels. The rough frame opening shall be 41.0" wide x 66.0" high.

L3

There shall be one (1) compartment on the left side over the rear wheels. The rough frame opening shall be 56.0" wide x 36.0" high.

L4

There shall be one (1) compartment on the left side behind the rear wheels. The rough frame opening shall be 41.0" wide x 66.0" high.

Body Compartments Officer-Side

R1

This compartment shall house the officer-side pump panel.

R2

There shall be one (1) compartment on the right side ahead of the rear wheels. The rough frame opening shall be 41.0" wide x 66.0" high.

R3

There shall be one (1) compartment on the right side over the rear wheels. The rough frame opening shall be 56.0" wide x 36.0" high.

R4

There shall be one (1) compartment on the right side behind the rear wheels. The rough frame opening shall be 41.0" wide x 66.0" high.

Body compartment Rear

B1

There shall be one (1) compartment at the back of the body. The rough frame opening shall be 50.0" wide x 65.0" high.

Ladder Storage Top-OS

A compartment shall be fabricated on the upper officer-side body to carry aluminum ladder(s). A hinged access door is installed at the back of the compartment. Top of compartment shall be open.

Hose Bed

A hose-bed shall be fabricated at the top of the body. The hose-bed shall be full-body-width with the exception of the driver-side which shall be inset to allow for suction hose storage and the officer-side inset to allow for ladder storage.

Note: Please refer to dimensional drawing for compartment measurements.

Each compartment shall be sealed before an interior coating is applied using a high quality paintable caulking. This will ensure the compartments to be leak free at any of its seams. All compartments will feature vents to allow air re-circulation. The tops of each compartment shall have aluminum checkerplate attached. This will provide for a skid resistant walkway.

Bumper Body Rear

There shall be a bumper installed at the back of the body. Heavy-duty steel plates shall be custom cut and formed to provide a rigid frame for the tailboard to attach to. The bumper support frame assembly shall be fully independent of the body frame, and shall be fastened to the chassis frame rails with grade 8 bolts. The tailboard shall be formed from embossed aluminum polished checkerplate to promote slip-resistance. A heavy aluminum channel shall be welded to the underside for additional support.

Body Support Frame

The bumper support frame assembly shall include framework to add support for the back lower body assembly.

Tow Hooks

Two (2) tow hooks shall be installed, one (1) bolted either side to the rear support frame assembly.

Fenderetts

There shall be stainless steel fenderetts installed on the body wheel well skirts, fastened to the skirts with stainless steel hardware.

Liners Wheel Well

There shall be wheel well liners installed in each body wheel well. The liners shall be 3/16" non-corrosive ABS material. The liners are fastened with stainless steel hardware, nylon shoulder washers and corrosion control paste on the bolt holes.

Mud Flaps

There shall be heavy-duty mud flaps installed at the rear wheels, attached to the body with stainless steel hardware. The mud flaps shall be 14" high x 24" wide and have an ACRES logo molded onto one side.

Rub Rails Body

There shall be anodized aluminum rub rails installed on the sides of the body, ahead of and behind the rear wheels. Plastic end caps shall be included on each end of the rub rails to provide a pleasing appearance. Stainless steel hardware shall be used to fasten the rub rails. Nylon shoulder washers are installed on each bolt, corrosion control paste is applied to each bolt hole prior to hardware insertion on the lower body.

Stairway

There shall be a collapsible stairway installed at the back driver-side of the body to access the upper-body. The assembly in its deployed state, shall extend past the back bumper to provide an ergonomic angled stairway. The bottom portion shall hinge-up and neatly fold above the brake/tail/turn lights, collapsing into a vertical compact unit. An over-center latch is used to captivate for storage.

The threads shall incorporate an aggressive thread pattern to offer secure slip-free footing.

Handrails shall be attached to both upper stairway stringers for additional support. Additional Handrails are included at the top of hose bed.

Step Platform

An embossed aluminum threadplate step/walkway shall be attached to the back-top of the body to allow users to step off the stairway and access the hose bed.

Shelving Comp (L2)

There shall be one (1) aluminum shelf installed in compartment L2, on the left-side forward of body wheels. The shelf shall be precision cut from 3/16" aluminum sheet, then polished and formed with a 2.5" vertical lip all around. All four corners of the shelf shall be left open for proper drainage. The shelf shall be installed in the compartment on four (4) vertically adjustable aluminum rails. Rubber interlocking floor tile shall be placed on the shelf.

Shelving Comp (L4)

There shall be two (2) aluminum shelves installed in compartment L4, Left-Back-Of-Wheel. The shelves shall be precision cut from 3/16" aluminum sheet, then polished and formed with a 2.5" vertical lip all around. All four corners of the shelves shall be left open for proper drainage. The shelves shall be installed in the compartment on four (4) vertically adjustable aluminum rails. Rubber interlocking floor tile shall be placed on the shelves.

Shelving Comp (R2)

There shall be three (3) aluminum shelves installed in compartment R2, right front of wheel. The shelves shall be precision cut from 3/16" aluminum sheet, then polished and formed with a 2.5" vertical lip all around. All four corners of the shelf shall be left open for proper drainage. The shelf shall be installed in the compartment on four (4) vertically adjustable aluminum rails. Rubber interlocking floor tile shall be placed on the shelf.

Shelving Comp (R4)

There shall be two (2) aluminum shelves installed in compartment R4, Right-Back-Of-Wheel. The shelves shall be precision cut from 3/16" aluminum sheet, then polished and formed with a 2.5" vertical lip all around. All four corners of the shelves shall be left open for proper drainage. The shelves shall be installed in the compartment on four (4) vertically adjustable aluminum rails. Rubber interlocking floor tile shall be placed on the shelves.

Roll-Out Tray (L4)

There shall be one (1) Slide-Master Roll-Out Tray installed, in body compartment L4, Left-Back-Of-Wheel. The slides shall be by SlideMaster, 100% Extension with a 600lb capacity, and include a lock-in and lock-out device. An aluminum tray with 2" up-turned flanges and rubber interlocking floor tile shall be included.

Roll-Out Tray (R4)

There shall be one (1) Slide-Master Roll-Out Tray installed, in body compartment R4, Right-Back-Of-Wheel. The slides shall be by SlideMaster, 100% Extension with a 600lb capacity, and include a lock-in and lock-out device. An aluminum tray with 2" up-turned flanges and rubber interlocking floor tile shall be included.

Roll-Out Trays (2) (B1)

There shall be two (2) Slide-Master Roll-Out Trays installed, in body compartment B1, Back-Of-Body. The slides shall be steel, include a lock-in and lock-out device and be powder-coated Black. An aluminum tray with 2" up-turned flanges and rubber interlocking floor tile shall be included.

* one (1) slide-out tray, 100% Extension x 600lb capacity, installed on compartment floor

* one (1) slide-out tray, 100% Extension x 300lb capacity, installed evenly in the upper section of compartment

Roll-Out Tip-Down Tray (L4)

There shall be one (1) roll-out tip-down tray installed in compartment L4, Left-Back-Of-Wheel, rated at 250lbs. The shelf shall be precision cut from 3/16" aluminum sheet, then polished and formed with a 2.5" vertical lip all around. All four corners of the shelf shall be left open for proper drainage. Rubber interlocking floor tile shall be placed on the shelf.

Roll-Out Tip-Down Tray (R4)

There shall be one (1) roll-out tip-down tray installed in compartment R4, Right-Back-Of-Wheel, rated at 250lbs. The shelf shall be precision cut from 3/16" aluminum sheet, then polished and formed with a 2.5" vertical lip all around. All four corners of the shelf shall be left open for proper drainage. Rubber interlocking floor tile shall be placed on the shelf.

Tool Board

A Tool Board Storage System shall be installed in the driver-side body wheel compartment. The tool board shall consist of one (1) fixed back wall PAC-TRAC tool mount panel and two (2) swing-out panels with an assortment of the following PAC Tool Mounts:

- * ten (10) Toolok
- * ten (10) Handelok
- * four (4) Flexmount - Short
- * four (4) Flexmount - Long

* Shall be installed in driver-side body compartment above the body wheels *

Tool Board

A Tool Board Storage System shall be installed in the officer-side body wheel compartment. The tool board shall consist of one (1) fixed back wall PAC-TRAC tool mount panel and two (2) swing-out panels with an assortment of the following PAC Tool Mounts:

- * ten (10) Toolok
- * ten (10) Handelok
- * four (4) Flexmount - Short
- * four (4) Flexmount - Long

* Shall be installed in officer-side body compartment above the body wheels *

Tool Board, OS Pump House

There shall be a Tool Board Unit installed, mounted to the officer-side pump house door. The unit shall consist of PAC tool mount extrusion and the following tool mounts:

- * six (6) Toolok tool mounts *

Tool Board (R2)

There shall be a vertical Tool Board installed in compartment R2. Two (2) drawer slides are included, one upper and one lower with a lock on the bottom slide.

The vertical tool board shall be precision cut from 3/16" aluminum sheet, then polished and formed for rigidity.

Spare Bottle Storage

There shall be a 4-Bottle spare SCBA bottle storage system installed. The assy is fabricated from aluminum sheet for the frame and poly sheet for non-scarring bottle support.

The assy shall be installed in compartment **R2**.

Tool Storage Drawer(s)

There shall be a 3-Drawer Tool Storage assembly installed on the floor of compartment L2, forward of body wheels. The storage system shall be fabricated from aluminum sheet. Heavy-Duty ball-bearing slides shall be used for the drawers. Dividers are included to insert as desired for compartment sizing.

Hose Bed Flooring

The top of the poly tank shall be grooved to allow for drainage forward and backward.

Hose Bed Divider

There shall be two (2) hose bed dividers installed in the upper hose bed. The dividers shall be produced from 3/16" aluminum sheet, and formed for rigidity. The top of the dividers shall have a flange, providing a flat surface for support for the hose bed tarp.

Cover Hose Bed

There shall be four (4) Aluminum Checkerplate Hose Bed covers installed, two (2) on each side of the hose bed. Two (2) per side are used to reduce cover size as one full-length is quite large. The checkerplate shall be NFPA compliant skid-resistant embossed material. The covers shall be hinged full-length with stainless steel piano hinge. Gas springs shall be included to support the covers in the open position.

Black Vinyl flaps are attached to the back of each hose bed cover to prevent deployment of hose. Bungee Cord is attached to the bottom of each tarp for securement purposes.

Rollup Doors

Compartment doors shall be equipped with AMDOR® brand roll-up doors complete with the following features:

- 1" aluminum double wall slats with continuous ball & socket hinge joint designed to prevent water ingress and weather tight recessed dual durometer seals
- Double wall reinforced bottom panel with stainless steel lift bar latching system
- Bottom panel flange with cut-outs for ease of access with gloved hands
- Reusable slat shoes with positive snap-lock securement
- Smooth interior door curtain to prevent equipment hang-ups
- One-piece aluminum door track side frame
- Top gutter with non-marring seal
- Non-marring recessed side seals with UV stabilizers to prevent warping
- Dual leg bottom seal (wear component material to be Type 6 Nylon)
- Door ajar switch system (magnetic) shall be provided by AMDOR.
- Door striker will provide support beneath the lift bar to prevent door curtain bounce and potential false door ajar indications.

* one (1) heavy-duty strap shall be attached to each door to aid in closing doors *

Ladder Storage

A ladder storage compartment shall be fabricated on the upper-right-side of the hose bed. A slide assembly is installed at the back of the compartment to assist in sliding the ladder in and out. A clamp mechanism is installed at the back to captivate the ladders in storage.

** A hinged/latched door shall be installed at the back of the ladder storage tunnel **

Lightbar

A Whelen Edge® Ultra Freedom IV™ Linear Super-LED® WCX Series 60" lightbar model # F4N0VLED shall be installed on the roof of the chassis cab. The F4N0VLED lightbar shall incorporate an anodized extruded heavy duty aluminum base and cover chassis with two front and rear RED/BLUE corner modules, two interior white modules, and two interior RED/BLUE modules. The front and rear of each corner module shall consist of 12 Linear Super-LEDs installed on a conformal coated PCB board with a thermal pad/aluminum bracket heat sink assembly. The long red interior Linear Super-LED lights shall incorporate 12 Super-LED installed on a conformal coated PCB board with a thermal pad/aluminum bracket heat sink assembly. The long white interior Linear Super-LED lights shall incorporate white Super-LEDs installed on a conformal coated PCB board with a thermal pad/aluminum bracket heat sink assembly.

All modules will utilize a Diamond Optix™ metalized reflector and two optic collimators. All electronic components shall be conformal coated to provide additional protection. The outer lens construction shall consist of two clear Uni-Dome top lenses with a clear center lens and utilize two liquid injection molded wiper seal dividers for maximum protection against environmental elements. Metal top shields installed on the Uni-Domes and center lens shall provide protection from climatic conditions and provides passive solar radiation to direct heat away from internal components.

The F4N0VLED shall have an electronic LC I/O board. The solid state I/O board shall be microprocessor controlled. The I/O board shall have built-in reverse polarity protection and output-short protection. The I/O board shall have the ability to flash twenty two Super-LED warning lights. There shall be a data bank of 12 Scan-Lock™ flash patterns including steady burn with low power and cruise light functions. The cruise light function shall allow the user the four corner modules as marker courtesy lights. The F4N0VLED will have the capability to install a traffic advisor in the rear of the lightbar. The I/O board shall also have outputs to add takedown, alley lights, and auxiliary lights for each set of lights to be controlled in pairs.

All lighthead shall be installed in the F4N0VLED with the aid of black polycarbonate snap-in mounting brackets. The solid state lightbar shall be vibration resistant. The lightbar will contain a 17' 2/c 8GA unterminated power cable and 17' 17/c 22GA unterminated control cable. All electronic components are covered by a five year factory warranty. The F4N0VLED shall include a permanent mount kit with hardware. Optional photocell available to automatically dim the F4N0VLED at night. Additional lights, mount kits, and driver side cable can be installed for an additional cost. Optional color lens filters available in blue, red, and amber. Optional smoked

lenses available at an additional charge.

The clear flashers shall automatically turn-on with the master lighting switch on and the park brake released. They shall automatically turn-off when the park brake is applied when arriving on scene. Clear flashing lights per NFPA are to be used only when "calling for right of way" (responding to a call) and shall be turned-off when "blocking right of way" at an emergency scene.

Additional Lightbar Warning Lights

Two (2) additional RED/BLUE LED Warning Lights shall be installed facing-forward on the lightbar, for a total of four (4) RED/BLUE and two (2) CLEAR.

Alley Lights

Two (2) Clear LED alley lights shall be included, one (1) at each end of the lightbar.

Scene Light, Lightbar

A Whelen model# PCH2F41 LED combination spot/flood scene light shall be installed front center of the lightbar. This light shall be switched at the chassis dash panel.

Whelen CORE

A Whelen CORE warning light management system shall be installed, offering the following features:

- * Core-R seamlessly integrates with the Whelen Command® software and can support remote firmware updates through the Whelen Cloud Platform®.

- * All-new modular design is built to scale with your needs and allows for access to every connector and fuse from the top of the box.

- * Vehicle-to-Vehicle Sync Utilizing the Vehicle-to-Vehicle Sync module, Core calms a scene by unifying flash patterns and tones on multiple emergency vehicles.

- * Dynamic Variable Intensity™ Patterns DVI™ patterns produce safer environments for first responders and motorists by gradually increasing and decreasing warning light intensity at nighttime emergency scenes.

- * WeCanX®, our newest CAN-based communication system provides true system synchronization, greater speed capabilities, expanded peripheral add-ons, and full support of diagnostics.

- * Firmware Updates: CenCom Core-R supports firmware updates through USB-C with Whelen Command® or over-the-air with The Whelen Cloud Platform®. All WeCanX devices support encrypted firmware updates.

Warning Lights Upper Rear Red/Blue

Two (2) Whelen, M9 Series, Model # M9 LED warning lights (with clear lens) shall be installed at the back upper body area, one (1) on the left and one (1) on the right side of the body. The warning lights shall incorporate Linear Super-LED® and Smart LED® technology. The M9R configuration shall consist of 24 red Super-LEDs and a red optic polycarbonate lens. The warning lights, with the aid of two screws, shall have the ability to be installed as a surface mount warning light.

The M9R shall utilize optic collimators and a metalized reflector for maximum illumination. The warning light shall include an internal flasher with 164 Scan-Lock™ flash patterns including a variety of CA Title 13 compliant patterns, left/right, top/bottom, in/out, and steady burn. The M9R shall also provide synchronize and low power features. The warning light shall meet KKK 1822F, NFPA 1901, and SAE specifications. The lens/reflector assembly shall be sealed and resistant to water, moisture, dust, and other environmental conditions. The hard coated lens shall provide extended life/luster protection against UV and chemical stresses. The light engine shall be installed at the rear of the unit and be vacuum tested to ensure proper sealing. The PC board shall be conformal coated for additional protection.

The M9R shall be furnished with 6"unterminated pigtails, a rubber gasket, screws, and screw grommets shall be included for installation. The warning light is covered by a five year factory warranty.

** the driver-side warn light shall be RED and the officer-side warn light shall be BLUE in color **

The warning lights shall be switched with the "Upper Level" warning light circuit.

Warning Lights Upper Sides Red/Blue

Four (4) Whelen, M9 Series, Model # M9 series LED warning lights (with clear lens) shall be installed at the upper sides of the body, two (2) on the left-side (front & rear) and two (2) on the right side (front & rear) of the body.

The M9R warning lights shall incorporate Linear Super-LED® and Smart LED® technology. The M9R configuration shall consist of 24 red Super-LEDs and a red optic polycarbonate lens. The warning lights, with the aid of two screws, shall have the ability to be installed as a surface mount warning light. The M9R shall utilize optic collimators and a metalized reflector for maximum illumination. The warning light shall include an internal flasher with 164 Scan-Lock™ flash patterns including a variety of CA Title 13 compliant patterns, left/right, top/bottom, in/out, and steady burn. The M9R shall also provide synchronize and low power features. The warning light shall meet KKK 1822F, NFPA 1901, and SAE specifications. The lens/reflector assembly shall be sealed and resistant to water, moisture, dust, and other environmental conditions. The hard coated lens shall provide extended life/luster protection against UV and chemical stresses. The light engine shall be installed at the rear of the unit and be vacuum tested to ensure proper sealing. The PC board shall be conformal coated for additional protection.

The M9R shall be furnished with 6" unterminated pigtailed, a rubber gasket, screws, and screw grommets shall be included for installation. The warning light is covered by a five year factory warranty.

** the driver-side and officer-side front warn lights shall be RED, the driver-side and officer-side rear warn lights shall be BLUE **

The lights shall be switched with the "Upper Level" warning light circuit.

Warn Lights Red/Blue, Chassis Bump-Ext

Two (2) Whelen M6 Series Model# M6*C Warning Lights (with clear lens) shall be installed, one (1) at the driver-side and one (1) at the officer-side of the front bumper extension face. Chromed bezels are included. Weather proof electrical connectors shall be used to connect the flashers to the apparatus harness.

* The driver-side warn light shall be RED and the officer-side warn light shall be BLUE * The lights shall be switched with the "Lower Level" warning light circuit.

Warn Lights Red/Blue, Chassis Fenders

Two (2) Whelen M6 Series Model# M6* Warning Lights (with clear lens) shall be installed, at the chassis fenders, one (1) at the driver-side and one (1) at the officer-side. Chromed bezels are included. Weather proof electrical connectors shall be used to connect the flashers to the apparatus harness.

* The driver-side warn light shall be BLUE and the officer-side warn light shall be RED * The lights shall be switched with the "Lower Level" warning light circuit.

Warn Lights Red/Blue, Body Fenders

Two (2) Whelen M6 Series Model# M6* Warning Lights (with clear lens) shall be installed, at the body fenders, one (1) at the driver-side and one (1) at the officer-side. Chromed bezels are included. Weather proof electrical connectors shall be used to connect the flashers to the apparatus harness.

* The driver-side warn light shall be RED and the officer-side warn light shall be BLUE * The lights shall be switched with the "Lower Level" warning light circuit.

Warn Lights Red/Blue, Body-Rear-Lower

Two (2) Whelen M6 series LED warning lights (with clear lens) shall be installed, at the body rear lower panels, one (1) each side. The warning lights shall incorporate Linear Super-LED® and Smart LED® technology. The M6* configuration shall consist of 18 Super-LED's and a red optic polycarbonate lens. The warning light, with the aid of two screws, shall have the ability to be installed as a surface mount warning light. The M6* shall utilize optic collimators and a metalized reflector for maximum illumination. The warning lights shall include an internal flasher with 164 Scan-Lock™ flash patterns including a variety of CA Title 13 compliant patterns, left/right, top/bottom, in/out, and steady burn. The M6* shall also provide synchronize and low power features. The M6* shall meet KKK 1822F, NFPA 1901, SAE and EC65 specifications.

The lens/reflector assembly shall be sealed and resistant to water, moisture, dust, and other environmental conditions. The hard coated lens shall provide extended life/luster protection against UV and chemical stresses. The light engine shall be installed at the rear of the unit and be vacuum tested to ensure proper sealing. The PC board shall be conformal coated for additional protection. The M6RC shall be furnished with 6" unterminated pigtailed, a rubber gasket, screws, and screw grommets shall be included for installation. The warning light is covered by a five year factory warranty.

* The driver-side warn light shall be BLUE and the officer-side warn light shall be RED *

These warning lights shall be installed in a vertical polished bezel with the brake/tail/turn lights and shall be switched with the "Lower Level" warning light circuit.

Traffic Advisor

The WeCanX 2250 Warning Light Array and Traffic Advisor packs more power into a sleeker design with a wide variety of light configurations to meet your needs. Combining the performance and reliability of our powerful ION™ T-Series™ lighthoods with the customization and control of WeCanX, its versatility makes it an ideal lighting solution for a wide range of applications.

WeCanX 2250 is slimmer than our 4500 Series, provides warning options, and allows aerial recognition. Angled end caps create a unique multi-angled light spread, and snap-in assembly allows lighthoods to be easily removed for customization and field serviceability. Whelen Command® enables endless configurations and lighthood placements are easily arranged within WeCad™.

Shall be configured with DUO Red/Amber lighthoods. 50.0" long, 10 lighthoods & 2 angled end caps.

Siren System

A Whelen Cencom CORE siren and light control system shall be provided and installed in the cab console. The Cencom Core has the ability to control the warning lights, scene lights, traffic advisor, and siren from a single keypad.

Siren Speaker

There shall be one (1) Whelen SP123BMC 100-watt Siren Speaker installed at the front bumper. A Chrome bezel shall be included.

DOT Lamps

There shall be a set of Whelen LED M6 Brake/Tail/Turn/Back-up Lamps installed in a polished chrome 4-place vertical bezel at the back of the apparatus. The top lamp on each side, shall be an amber arrow for turn function, the second position a red brake lamp, the third position a clear back-up lamp and the lower position a red flasher.

Five (5) Red LED clearance lamps shall be installed on the back bumper, one (1) on each corner and three (3) on center of the bumper.

Four (4) Red LED clearance lamps shall be installed at the back-top of the body sides, two (2) facing sideways and two (2) facing backwards. One (1), Red LED 3-lamp ID bar shall be installed at the top center of the body. This ID bar shall activate as a third brake lamp.

There shall be two (2) Amber LED turn signal/clearance lamps installed, one (1) on each side at the body fenders.

License Plate Lamp

There shall be a stainless steel bracket installed at the back of the body to carry a license plate. The top of the bracket shall have a formed lip to protect an LED lamp, installed to illuminate the license plate.

Scene Lights Body-Sides

Four (4) Whelen M9 Series Model M9 EZ Scene Lights shall be installed, two (2) at the driver-side and two (2) at the officer-side, front and rear, upper surface of the body.

The M9 EZ Scene Light features expanded zone efficiency, enhanced optics, and increased functionality to provide a powerful scene lighting solution for every situation. Plus, select from multiple turn-on styles and low-power settings for more efficient lighting output and performance. M Series lightheads feature a unique lens shape and patented Linear-LED® reflector assembly for unmatched high-intensity illumination with low current consumption.

The M9 EZ's dynamic functionality lets you shine the light where you need it the most

Features:

- Redesigned optic aesthetics, light output, and light pattern optimizes light dispersion
- Gradient Opti-Scenelight™ technology enables efficient use of light
- Hard-coated lenses minimize environmental damage from sand, sun, salt, and road chemicals
- Selectable turn-on functionality
- Multiple turn-on styles ranging from instant to gradual (Slow, Medium, Fast, Instant)
- Three low-power settings provide situation-specific lighting for a variety of scenarios
- Surface mount
- Includes a 6" pigtail

The scene lights shall include a chrome trim ring, and be switched at the cab console.

Scene Lights Body-Rear

Two (2) Whelen M9 Series Model M9 EZ Scene Lights shall be installed, one (1) on each side at the back, upper surface of the body.

The M9 EZ Scene Light features expanded zone efficiency, enhanced optics, and increased functionality to provide a powerful scene lighting solution for every situation. Plus, select from multiple turn-on styles and low-power settings for more efficient lighting output and performance. M Series lightheads feature a unique lens shape and patented Linear-LED® reflector assembly for unmatched high-intensity illumination with low current consumption.

The M9 EZ's dynamic functionality lets you shine the light where you need it the most

Features:

- Redesigned optic aesthetics, light output, and light pattern optimizes light dispersion
- Gradient Opti-Scenelight™ technology enables efficient use of light
- Hard-coated lenses minimize environmental damage from sand, sun, salt, and road chemicals
- Selectable turn-on functionality
- Multiple turn-on styles ranging from instant to gradual (Slow, Medium, Fast, Instant)
- Three low-power settings provide situation-specific lighting for a variety of scenarios
- Surface mount
- Includes a 6" pigtail

The scene lights shall include a chrome trim ring, and be switched at the cab console.

Light Switch Request

The side & rear scene lights shall be switched and labelled as follows:

- * shall be switched at cab console & pump operators panel
- * driver-side scene lights = LEFT SCENE
- * officer-side scene lights = RIGHT SCENE
- * rear scene lights = REAR SCENE
- * the rear scene lights shall turn-on automatically when transmission is placed in reverse

The switch legends shall be back-lighted.

Lights Pump Panels

The pump panels shall be illuminated by the led strip light provided with the roll-up doors.

Step Lights Chassis

There shall be Eight (8) Tecniq LED step lights installed, four (4) each side at the chassis cab entry steps. These lights shall turn-on automatically when a cab door is opened and are also switched by a cab dash switch.

Step Lights Rear

There shall be three (3) Tecniq D07 LED step lights installed at the back of the body to illuminate the ladder and bumper surface. Each led light is rated at 240 lumens. The lights shall be installed on the back wall centered on each side compartment back panel.

** The lights shall be activated with the ground lights **

Ground Lights Front Bumper

There shall be two (2) Tecniq LED ground lights installed, one (1) each side beneath the front bumper to illuminate the ground. These lights shall turn-on automatically when a cab door is opened and are also switched by a cab dash switch.

Ground Lights Chassis Steps

There shall be four (4) Tecniq LED ground lights installed, two (2) each side beneath each cab entry step to illuminate the ground. These lights shall turn-on automatically when a cab door is opened and are also switched by a cab dash switch.

Ground Lights Body-Front

There shall be two (2) Tecniq LED ground lights installed, one (1) each side beneath the front of body to illuminate the ground. These lights shall turn-on automatically when a cab door is opened and are also switched by a cab dash switch.

Ground Lights Back-Bumper

There shall be two (2) Tecniq LED ground lights installed, one (1) each side beneath the back bumper to illuminate the ground. These lights shall turn-on automatically when a cab door is opened and are also switched by a cab dash switch.

Interior Lights Front Bumper Comp

There shall be two (2) Tecniq LED interior lights installed, at the front chassis grille to illuminate the front bumper extension/compartment.

* The lights shall be switched by the ground light switch circuit *

Interior Lights Engine Compartment

There shall be two (2) Tecniq LED interior lights installed, one (1) each side at the engine compartment to illuminate the engine compartment. Each lamp shall be rated at 750 lumens.

These lights shall be switched by the ground light switch.

Interior Lights Crew-Cab

There shall be two (2) Tecniq Red/Clear LED interior lights installed, one (1) centered front and one (1) centered rear of cab. The lights shall be switched manually.

Interior Lights Pump House

There shall be two (2) Tecniq SteelHead LED work lights installed, one (1) each side at the pump house compartment to illuminate the pump house. Each lamp shall be rated at 750 lumens.

These lights shall be switched by a switch at the pump control panel.

Interior Lighting Body-Compartments

All body compartments shall be illuminated by LED strip lighting inserted into the back of the vertical rollup door tracks. One (1) full height strip shall be included on each side of the door opening. The lighting shall turn-on by a magnetic door switch whenever the door is in the open position.

Interior Lights Hose Bed

There shall be four (4) Tecniq LED interior lights installed, two (2) on the under-side of each hose-bed cover to

illuminate the hose bed.

** Door-Ajar sensors shall be included **

Ladder Extension

There shall be a Series 900-A 24' Duo-Safety Aluminum Extension Ladder supplied.

Ladder Roof

There shall be a Series 775-A 14' Duo-Safety Aluminum Roof Ladder supplied.

Ladder Folding

There shall be a Series 585-A, 10' Duo-Safety Folding Aluminum Ladder supplied. The ladder shall be fastened to the apparatus with rubber PAC tool mounts.

Suction Hose

There shall be two (2) 6" x 10' lengths of lightweight suction hose supplied with the apparatus. Long-Handle Female/Male NH Couplings are included.

The suction hose shall be stored in the upper hose-bed, beneath the hose-bed cover.

Strainer Low-Level 6" NH

There shall be a Task-Force-Tips 6" F NH High Volume Low-Level Strainer supplied. The strainer is made of hard anodized and powder-coated aluminum. Clog-resistant stainless steel filter has over twice as much flow area as a 6" hose. This keeps friction loss down to 0.5 psi (1" Hg) at 1500 gpm and reduces the potential for air vortexes to form as water sinks towards the 2.5" minimum usable depth. Oversized sealed ball pivot allows 45° range of hose angle without constricting the flow path.

A Jet Siphon is included and substantially increases suction lift capability. The Jet Siphon is also useful for tank shuttle operations, pump priming and dewatering without the need for a trash pump.

A Yellow Poly Float device shall be included, allowing for floatation if desired.

Pike Poles

There shall be two (2) 10' Fiberglass Handled Pike poles supplied with the apparatus. Two (2) rubber PAC tool mounts shall be included.

Wheel Chocks

There shall be Two (2) Rubber Wheel Chocks supplied with the apparatus.

Spanner/Hydrant Wrench Sets

There shall be two (2) sets of (2) spanner & (1) hydrant wrench sets supplied and installed onto the apparatus, one (1) set on each side at the pump panels.

Storz Wrench Set

There shall be one (1) Aluminum Storz Wrench Set installed at the Officer-Side pump panel for use with the storz discharge adapters.

Fire Extinguisher

A 10lb ABC Fire Extinguisher shall be supplied/installed with a vehicle mounting bracket. The location to be discussed with the Fire Dept.

Fire Extinguisher

Two (2) 20lb Sentry Dry Chem AA20 Fire Extinguishers shall be supplied/installed with vehicle mounting brackets. The location to be discussed with the Fire Dept.

Safety Items

The following items shall be included with the apparatus:

- * Triangular Flare Kit
- * First Aid Kit
- * 5lb Fire Extinguisher

Body Underside Coating

There shall be a rubberized undercoat applied to the underside of the body. This coating offers excellent abrasion protection, sound deadening and corrosion protection.

Paint Body Compartments

The body compartment interiors shall be coated with the following paint process:

- * all interior surfaces shall have an acid-etch solution applied, then pressure washed/cleaned
- * one coating of Zolatone Silver primer shall then be applied
- * all compartment seams shall be caulked to prevent leakage
- * a top-coat of Zolatone Silver-Grey speckle-coat shall be applied

Paint Process Body

High Quality Urethane paint will be applied, to provide a high luster and long lasting paint finish, per the following process:

- * the structure to be painted will have all hardware removed to ensure that all areas are protected by paint
- * an acid-etch solution shall be applied and thoroughly pressure washed/cleaned
- * the body shall then be rinsed with reverse-osmosis water
- * all areas not requiring paint are then masked
- * all joints/seams that require body work shall have body filler compound material applied and then sanded
- * all seams are then caulked for sealing purposes
- * High-Build PPG epoxy primer is applied
- * Cabinet interiors are then sprayed with speckle/texture coat.
- * the exterior body surface to be painted, shall then be sanded
- * all sanded areas are then thoroughly wiped down multiple times with a cleaning solution, and then tacked
- * every front facing side of the body, and high wear areas are masked and bedliner is applied for enhanced durability.
- * two (2) coats of PPG urethane single-stage color are applied over the bedliner area and smooth paint areas to ensure a sealed-off paint coat around the apparatus.

The front face of the body shall be coated with a box-liner coating for enhanced durability.

Paint Chassis-Cab

The chassis cab shall be painted Single-Tone, RED.

Paint Body

The body shall be painted Single-Tone, RED.

Chevron Red/Yellow-Green

There shall be Reflexite Red & Yellow-Green 6" reflective chevron striping installed on the back of the body. The design shall have the striping applied outwards & downwards at a 45 degree angle from the centerline of the body. The colors shall be applied alternately. The entire back of the body shall be covered.

Striping Front Bumper

A 4" white reflective stripe shall be attached to the width of the front bumper.

Reflective Striping

There shall be "White" Reflexite V-92 Reflective Striping installed on the front & sides of the apparatus per NFPA 1901. The side design shall feature a 6" stripe running mid-body and a second 1" stripe applied beside the 6" stripe, spaced 1/2" apart. A "Z" pattern shall be applied at the body front door. The 1" stripe shall be applied above the 6" stripe at the chassis cab and transition through the "Z" pattern to the bottom of the 6" stripe applied to the body.

A proof shall be sent to the Fire Dept for approval before installation.

Decals

There shall be Fire Department Door Decals installed on the chassis cab doors. The design shall be provided or approved by the Fire Dept. Material shall be Regular Reflective Vinyl.

Apparatus Final Test

The apparatus shall be subjected to a final inspection and 3rd party pump tested to ULC-S515-13. A non-affiliated organization shall perform the test with calibrated testing equipment. A label shall be engraved and attached to the pump operators panel, to indicate that the apparatus met the required performance criteria.

Apparatus Labels

The following labels shall be applied to the apparatus:

- * NSM - National Safety Mark
- * Apparatus Fluids Plate
- * Apparatus GVWR, Length, Height Label
- * Warning - Apparatus Seating Capacity
- * Warning - Occupants Must be Seated and Belted
- * Warning - Do Not Wear Helmets While Riding
- * Warning - Only Trained Operators to Operate Apparatus
- * Warning - Hot Exhaust
- * Warning - Step Fall Hazard
- * Warning - Do Not Ride on Step when Apparatus in Motion

Apparatus Length-Height

The following dimensions shall apply to the completed apparatus. Any critical dimensions that apply shall be noted here.

- ** Apparatus Length - SEE DRAWING
- ** Apparatus Height - SEE DRAWING

Provincial Truck Safety

The apparatus shall be subject to a provincial truck safety inspection prior to delivery.

Manual

There shall be two (2) operation & maintenance manuals included with the apparatus. The manuals shall be electronic on USB cards.

Warranty

A Warranty policy shall apply to the apparatus. The policy shall include 2-year bumper to bumper coverage. All private labelled products (ex. Chassis, Fire Pump, Poly Tank, Emergency Lighting etc.) shall be covered by their respective manufacturer's warranty policies. See attachment for details.

Apparatus Delivery & Training

The completed apparatus shall be subject to a final inspection. It shall then be delivered to the customers facility under its own power. An authorized company representative shall deliver the apparatus and perform operational training to the Fire Department upon arrival.

Acres Industries Inc.

Warranty Statement

Acres Industries Inc. warrants to the Original Purchaser, that the fabricated aluminum structure of the Emergency Apparatus, to be free of defects in material and workmanship. Acres will repair or replace (at its sole discretion) any defective products within the Warranty period. This is providing that the Apparatus has been operated and maintained in a reasonable manner. This Warranty is NOT applicable to issues resulting from neglect of proper maintenance, abuse, misuse and alterations to the Apparatus.

Acres may elect to repair or replace any defective component at the customer's facility, at a factory Authorized Service Center or have the unit returned to the factory freight prepaid by the customer.

Any unauthorized service or repairs performed on the Apparatus without written approval from Acres will not be warranted.

Acres will not be held liable for any incidental or consequential damages resulting from the use of the Apparatus, and assumes no responsibility or liability for expenses incurred in the removal and/or re-installation of products requiring service and/or repair.

There shall be no other warranties, expressed or implied, than the warranties stated herein, and Acres reserves the right to modify this warranty statement at any time without prior notice.

All other items installed on the Apparatus, including Pumps, Warn and Scene Lighting, Electrical Equipment, Hardware and miscellaneous items are warranted by their original manufacturer.

Acres' warranty Does Not apply to these private labeled products.

All Paint Coatings both interior and exterior are warranted by the original manufacturer/applicator and include loss of adhesion, loss of gloss, peeling and blistering.

Warranty defined as follows:

1. Chassis..... See Document
2. Waterous Fire Pump See Document
3. Poly Water Tank See Document
4. Whelen Warn/Scene Lighting See Document
5. FRC Governor/Displays/Lighting See Document
6. Structural Aluminum Body 15 Years
7. Electrical System by Acres 5 Years
8. Paint Coatings (Limited) 10 Years
9. All other components 2 Years

This warranty does not apply to:

1. To normal service & adjustments
2. To commercial chassis and associated equipment furnished with chassis, signaling devices, generators, batteries, or other trade accessories in as much as they are usually warranted by their respective manufacturers.
3. Mileage and Accommodations for warranty/service trips

All Warranties Become Effective as of Manufacture Date on Apparatus Label & after Apparatus has been Paid in Full.

Waterous Seven-Year Limited Warranty

WATEROUS warrants, to the original Buyer only, that products manufactured by WATEROUS will be free from defects in material and workmanship under normal use and service for a period of Seven (7) years from the date the product is first placed in service, or Seven and one-half (7-1/2) years from the date of shipment by WATEROUS, whichever period shall be the first to expire; provided the Buyer notifies WATEROUS, in writing, of the defect in said product within the warranty period, and said product is found by WATEROUS to be nonconforming with the aforesaid warranty. When required in writing by WATEROUS, defective products must be promptly returned by Buyer to WATEROUS at WATEROUS' plant at South St. Paul, Minnesota, or at such other place as may be specified by WATEROUS, with transportation and other charges prepaid. A Returned Material Authorization (RMA) is required for all products and parts and may be requested by phone, fax, email, or mail. The aforesaid warranty excludes any responsibility or liability of WATEROUS for:

- (a) damages or defects due to accident, abuse, misuse, abnormal operating conditions, negligence, accidental causes, use in non-firefighting applications, or improper maintenance, or attributable to written specifications or instructions furnished by Buyer;
- (b) defects in products manufactured by others and furnished by WATEROUS hereunder, it being understood and agreed by the parties that the only warranty provided for such products shall be the warranty provided by the manufacturer thereof which, if assignable, WATEROUS will assign to Buyer, if requested by Buyer;
- (c) any product or part, altered, modified, serviced or repaired other than by WATEROUS, without its prior written consent;
- (d) the cost of dismantling, removing, transporting, storing, or insuring the defective product or part and the cost of reinstallation; and
- (e) normal wear items (packing, strainers, filters, light bulbs, anodes, intake screens, mechanical seals, etc.).

ALL OTHER WARRANTIES ARE EXCLUDED, WHETHER EXPRESS OR IMPLIED BY OPERATION OF LAW OR OTHERWISE, INCLUDING ALL IMPLIED WARRANTIES OF MERCHANTABILITY OR FITNESS FOR A PARTICULAR PURPOSE. IN NO EVENT, WHETHER AS A RESULT OF BREACH OF CONTRACT, WARRANTY, TORT (INCLUDING NEGLIGENCE), STRICT LIABILITY, OR ANY OTHER CAUSE OF ACTION, SHALL WATEROUS BE LIABLE FOR ANY PUNITIVE, SPECIAL, INCIDENTAL OR CONSEQUENTIAL DAMAGES, OR FOR PERSONAL INJURY OR PROPERTY DAMAGES.

The exclusive remedy of Buyer and the sole liability of WATEROUS, whether based on contract, warranty, tort or any other basis of recovery whatsoever, is expressly limited at the election of WATEROUS to:

- (a) the replacement at the agreed point of delivery of any product or part, which upon inspection by WATEROUS or its duly authorized representative, is found not to conform to the limited warranty set forth above, or
- (b) the repair of such product or part, or
- (c) the refund or crediting to Buyer of the net sales price of the defective product or part.

BUYER'S REMEDIES CONTAINED HEREIN ARE EXCLUSIVE OF ANY OTHER REMEDY OTHERWISE AVAILABLE TO BUYER.

Waterous Company
125 Hardman Avenue South
South St. Paul, MN 55075 USA
www.waterousco.com



F-2891 (04/15/20)



LIFETIME SERVICE WARRANTY

United Plastic Fabricating, Inc. (hereinafter called "UPF") warrants each POLY-TANK®, Booster/Foam Tank POLYSIDE® Wetside Tank, Integrator Tank/Body, ELLIPSE™ Elliptical Tank, Ellip-T-Tank Tank and DEFENDER™ Skid Tank to be free from defects in material and workmanship for the service life of the original vehicle (vehicle must be actively used in an emergency response for fire suppression). All UPF Tanks must be installed and operated in accordance with the UPF Installation and Operating Guidelines. Failure to do so can void the warranty.

Every UPF Tank is inspected and tested before leaving our facility. Should your UPF Tank require service, please notify UPF via email, fax, in writing or by calling UPF at 1-978-975-4520. Please provide the serial number, a description of the service request, the location along with the phone number and name of the contact person. Our goal is to have scheduled work completed within a reasonable time period.

Under a valid warranty claim, UPF will cover the cost to repair the UPF Tank including the customary and reasonable costs to make the tank accessible such as the removal and reinstallation of the tank if authorized in advance (pre-approved) by UPF. The warranty will not cover tanks that have been improperly installed, operated, misused, abused, or modified from its intended or designed use. Serial number must not have been altered, defaced or removed. Tanks that are not stored or installed properly which results in the tank suffering UV damage will not be covered by this agreement.

Should UPF determine that the service claim is valid under this warranty for a tank located outside of the United States and Canada, UPF will assume the costs for labor and material for the warranty repair as described above plus all travel costs to the U.S. port of embarkation. Costs for airline travel outside of the U.S. and Canada will not be the responsibility of UPF.

In the event the tank shall become stationed in an area of the world that is considered to be a war zone or where unsafe conditions exist for the safe passage of United States Nationals, as reported by the United States Department of State, (<http://www.state.gov>), and a request to perform service or warranty repairs, UPF reserves the right to refuse to honor such requests. It is the purchaser's responsibility to relocate the tank to an area where such repairs can be performed without undue risk to UPF employees or their designee. UPF will make every reasonable effort to support our products through alternative means.

For Ellipse™ elliptical tanks, a separate five year warranty provided by the subcontractor is applied to the sub-frames, chute linings (rubber isolation strips) and metal components. The stainless steel wrap provided by UPF shall be warranted by the subcontractor performing the wrap installation in accordance with their warranty in place at the time of the installation. UPF will not be liable for any warranty costs associated with the wrap, sub-frames, chute linings (rubber isolation strips) and metal components but will assist with all claims on behalf of its customer.

For PolySide® wetsided tanks and Integrator™ Tank/Body units, all polypropylene components related to the tank shall carry the standard UPF lifetime

service warranty. Other polypropylene components, including but not limited to compartments, wheel wells, fenders and other body related components shall be warranted by UPF for a period of ten years. The warranty for the PolySide® and Integrator™ units excludes paint or hardware, which shall be covered by the manufacturer of the paint/hardware.

All UPF tanks 50 gallons or less utilized for non-fire applications and installed on specialty vehicles such as ATVs, trailers, boats, etc. are covered under a separate warranty policy available from UPF. Further, UPF Protector™ foam and water trailers are warranted under a separate warranty policy available from UPF.

This UPF warranty is transferable within the United States only with prior written approval by UPF (except an original apparatus manufacturer may assign this warranty to the first titled owner/lessee of the apparatus).

UPF will NOT reimburse any unnecessary work and/or work that has not been pre-approved. Any and all third party charges must be pre-authorized and approved in writing by UPF prior to commencing the work. Any unauthorized third party repairs, alterations, actions or modifications will not be covered and can void the warranty. UPF will be the sole determining authority as to whether a service claim will be valid and covered under this warranty.

In no event will UPF be liable for an amount in excess of the purchase price of the booster/foam tank at the time of manufacture or for any loss or damage, whether direct, indirect, incidental, consequential, or otherwise arising out of failure of its product. Loss of contents (water, foam, etc.) shall not be the responsibility of UPF. Further, UPF is not responsible for costs associated with service repairs to chassis, sub-frames, bodies, valves, dumps, hoses, pressure vacuum vents, and other components (i.e. liquid level transducers, etc.). Further, UPF will not cover the cost for travel of the vehicle to and from a repair facility.

This warranty contains the entire warranty. It is the sole warranty and price agreements or representation, whether oral or written, are either merged herein or expressly cancelled. UPF neither assumes, nor authorizes any person supposing to act on its behalf to change, nor assume for it, any warranty or liability concerning its product.

This warranty gives you specific legal rights, and you may also have other rights which vary from state to state. Some states do not allow exclusion or limitation or incidental or consequential damage, so the above limitation or exclusion may not apply to you. Since some states do not allow limitations on the length of an implied warranty, the above limitation may not apply to you.

THERE ARE NO WARRANTIES, EXPRESSED OR IMPLIED, WHICH EXTEND BEYOND THE DESCRIPTION OF THE FACE HEREOF. THERE IS NO EXPRESS OR IMPLIED WARRANTY OF MERCHANTABILITY OR A WARRANTY OF FITNESS FOR A PARTICULAR PURPOSE. ADDITIONALLY, THIS WARRANTY IS IN LIEU OF ALL OTHER OBLIGATION OR LIABILITIES ON THE PART OF UPF.

WHELEN[®] USER DIRECT LIMITED LIFETIME WARRANTY FOR CERTAIN WHELEN PRODUCTS IN THE FIRE/EMS MARKETS

Whelen Engineering Company, Inc. ("Whelen") warrants the following products manufactured on or after January 1, 2021 (as stamped on the products) to be free from defects in material and workmanship for the duration that the following vehicles on which the products are initially installed are in-service at their original owner (a limited lifetime warranty); provided the products have been installed and operated in accordance with Whelen's manufacturer recommendations. This limited lifetime warranty is between the first purchaser (ultimate user) only and Whelen.

During the limited lifetime warranty period, the Factory Repair Center or an Authorized Whelen Repair Center will repair or replace (at its option and cost) any parts or electronic assemblies of the covered product that disclose a defect in material or workmanship. For warranty consideration, the user shall obtain a prior return merchandise authorization (RMA) by contacting Whelen's Technical Support Group at custserve@whelen.com or by calling (860) 526-9504 and then return the product freight prepaid to Whelen at 51 Winthrop Road, Chester, CT 06412-0684 or an Authorized Whelen Repair Center. The Repair Center will return the repaired unit, transportation cost prepaid.

Product families to which the limited lifetime warranty applies:

- Freedom Series Lightbars
- M-Series
- L31 Series
- B6 Series
- Micro Freedom Series
- Pioneer Scene Lighting (Excludes Pioneer Life)
- PSTANK2
- PSCOMP – Illumination Series
- TANF65 or 85 TA Series
- 6" and 8" LED Ambulance Series

Vehicles to which the lifetime limited warranty applies:

This warranty applies to the above-listed products installed only on fire and emergency medical services apparatuses built by original equipment manufacturers and listed in NFPA 1901, NFPA 1906, NFPA 1917, KKK-1882F, CAAS, and AMD standards, including pumpers, rescues, aerials, wildland, and ambulances.

Limitations on Limited Lifetime Warranty

1. This warranty does not apply to normal cosmetic wear, i.e., lens degradation and/or coloring.
2. All warranted products must have been purchased through an authorized Fire & EMS original equipment manufacturer (OEM)
3. This warranty is not applicable to any Whelen product that has failed from damage as a result of incompatible chemicals (including de-icing or road treatment) or cleaning products, or due to accident, abuse, misuse, neglect, physical damage, improper installation, ordinary wear and tear, excessive voltages, or any alteration to the product that affects, in Whelen's judgment, the product's intended use and service, cut wires eliminating the possibilities of repair and/or interactions with third party devices
4. Each Whelen product sold is covered only by the official warranty in effect at the time of purchase.
5. Whelen will not be held liable for any incidental, punitive, special or consequential damages, including without limitation, loss of use of the vehicle or equipment, loss of time, inconvenience, loss of profit, loss of business or any other damages, losses, or expenses arising from the sale, handling, or use of the products and assumes no responsibility or liability for expenses incurred in the removal and/or re-installation of products requiring service and/or repair; nor the packaging, handling, and shipping to the Factory Repair Center or Authorized Whelen Repair Center; nor for the handling of products returned from the repair center after service or repair.
6. This warranty will be void when using or substituting other than all genuine Whelen system components, such as remote head assemblies, shielded cables, siren amplifiers, and siren speakers.
7. THIS WARRANTY IS IN LIEU OF AND EXCLUDES ALL OTHER WARRANTIES NOT EXPRESSLY SET FORTH HEREIN, WHETHER EXPRESS OR IMPLIED, INCLUDING BUT NOT LIMITED TO ANY WARRANTIES OF MERCHANTABILITY OR FITNESS FOR A PARTICULAR PURPOSE.

Whelen reserves the right to modify this warranty statement at any time or discontinue, modify, or upgrade any products of its manufacture with design improvements without prior notice.

All Non-Whelen manufactured items that are sold by Whelen are covered by that manufacturer's warranty and are excluded from this warranty statement (such as GTT Emitters and batteries).

This warranty gives you specific rights, and you may also have other rights which vary from state to state.

WHELEN[®]
ENGINEERING COMPANY, INC.

51 Winthrop Road, Chester, CT 06412-1036
(860) 526-9504 www.whelen.com

† The only AUTHORIZED WHELEN REPAIR CENTER(S) are predetermined by the Whelen Factory via official listing obtained from Whelen Engineering Company, Chester, CT.
* New/Revised 13403A-06/24/21 © 2021 Whelen.



VEHICLE-MOUNTED PUMP

CS/CSU



K



PA



TC20

Transmission
Options

C20

Designed with a two-piece, horizontally split body with intake and discharge passageways in a single casting and on the same level. This design provides the lowest possible height, a lower center of gravity, and more room for hose reels, hose beds and other equipment.

PERFORMANCE

- 750 to 2250 GPM (3000 to 9000 l/min)
- Maximum Pressure: 400 PSI (34 bar)

AVAILABLE MOUNTING

- Mid-Ship: Equipped with C20 Chain Drive Transmission
- PTO: Equipped with PA Chain Drive PTO or K Series Gear Drive Transmission
- Rear Mount: Equipped with TC20 Transmission

SPECIFICATIONS: VEHICLE MOUNTED: CS/CSU

Single Stage Centrifugal Fire Pump

CS/CSU Pump Performance							
Model	FLOW			PRESSURE			
	GPM	l/min	l/sec	PSI	bar	kPa	MPa
CS	750, 1000, 1250	3000, 4000, 5000	100, 120, 130, 150	150	10	1000	1.0
CSU	1500, 1750, 2000, 2250	6000, 7000, 8000, 9000					

Pump Features

Casing

Two-piece, horizontally-split, high-tensile, close grained gray iron or bronze (optional). All passageways are carefully matched to assure the very best hydraulic flow characteristics.

Wear Rings

Bronze, reverse-flow, labyrinth-type replaceable wear rings increase pump life and keep maintenance costs to a minimum.

Impellers

Bronze impeller, balanced both mechanically and hydraulically for vibration-free operation. Flame-plated impeller hubs are standard on CSU to assure longer life despite the presence of abrasives in the water supply (optional on CS).

Impeller Shaft

Heat-treated stainless steel is ground at all critical areas, polished under packing. An exclusive two-piece impeller shaft allows separation of the transmission from the pump without disassembling either component. This simplifies repair procedures, resulting in less down time.

Bearings

Three deep-groove, anti-friction ball bearings, located outside the pumping chamber, give support and proper alignment to the impeller shaft assembly. Bearings are oil or grease lubricated, completely separated from the water being pumped, and protected by seal housings, flinger rings and oil seals.

Shaft Seal

Seal housings on packed pumps are equipped with braided flexible graphite (BFG) rings held in place by a split bronze gland which is fully removable and adjustable. BFG packing improves heat dissipation, reduces maintenance and minimizes shaft wear. Self-adjusting, spring-loaded mechanical seals are available which eliminate leakage and routine maintenance.

Flinger Rings

Located on the impeller shaft between seal housings and bearing housings, flinger rings provide added protection and keep water and foreign matter out of the bearings.

Oil Seals

Standard lip type for lubrication and additional bearing protection from dirt and water.

Simple to Operate

- Power shift system engages the pump with indicating lights confirming the shift is complete.
- Single control activates the priming system, automatically opening the priming valve and starting the primer.
- Single ON-OFF control activates the automatic relief valve systems.

Versatility

The Waterous CS/CSU pump was designed with versatility in mind. Waterous offers a complete selection of intake and discharge locations and sizes, and overall piping arrangements.

- Discharge locations are available to meet any need, and sizes from 2-1/2 inches to 5 inches are available.
- Extra large discharge system assures you of the most efficient water delivery system available to the fire service.
- Thoroughly tested to meet NFPA and special contract provisions.

Optional Equipment

- Priming System, see F-2418
- Pressure Control Systems:
 - Discharge Valve, see F-897
 - Intake Relief Valve, see F-2192
- Corrosion Protection – Zinc Intake Screens and Anodes
- Overheat Protection Manager, see F-2422
- Drain Valves, see F-1158
- 3-1/2" Tank to Pump Valve
- Discharge Valves, see F-1161
- Pneumatic Shift
- Five-Year Limited Warranty with Total Protection Package (TPP-5)
- Transmissions Available:

C20 Series Transmission

Housings: High-strength aluminum, three-piece, horizontally-split.

Drive Ratios: 1.27, 1.41, 1.48, 1.58, 1.69, 1.79, 1.88, 1.97, 2.03, 2.27, 2.46

Shafts: Drive line shafts made from alloy steel forgings, hardened and ground to size, 2.35 inch 46-tooth involute spline.

Drive and Driven Sprockets

Made of steel. All sprockets are hardened and have ground bores.

Drive Chain

High-strength involute form chain.

Bearings

Deep-groove, anti-friction ball bearings give support and proper alignment to the impeller shaft assembly. Bearings are oil-splash lubricated, completely separated from the water being pumped, and protected by a V-ring and oil seals.

Lubrication System

An internal lubrication system delivers lubricant directly to the drive chain. This unique design eliminates the need for an external lubrication pump and auxiliary cooling.

Shift Mechanism

Constant-mesh, two-position sliding collar that engages all teeth simultaneously. In-cab controlled pneumatic shift. An internal locking mechanism provides a positive lock in PUMP or ROAD position.

PA Series Transmission

Housings: Cast aluminum body

Drive Ratios: 1.71, 1.91, 2.05

Drive & Driven Sprockets

Made of a steel. All sprockets are hardened and have ground bores.

Drive Chain

High-strength involute form chain.

Bearings

Anti friction ball bearings

Optional Rear Facing Output Shaft

1-3/8-10 SAE spline for Spicer 1280 or 1310 series end yokes

Conditions of Sales

For details on Waterous Conditions of Sales, refer to F-2190, *Conditions of Sales* located on the Waterous web site at www.waterousco.com or by contacting Waterous.

Warranty

Waterous Five-Year Limited Warranty



FOAM SYSTEMS

CAFSystems™

FIRE PUMPS

FOAM PROPORTIONERS

AQUIS™ 3.0



BENEFITS OF FOAM

- 50% more effective than plain water
- Improved firefighter safety
- Faster knockdown time
- Less property damage
- Less water used

It's not easy to properly proportion fire-suppressing foam. To get the ratios right, you need to compensate for a number of variables. Doing so demands world-class engineering coupled with dependable flow meter technology. In other words, you need The Aquis™ Foam Proportioner from Waterous. It delivers a level of performance and reliability typically reserved for more expensive foam proportioner systems.

PERFORMANCE

- 3.0 GPM @ 150 PSI
- 11.3 l/min @ 10 bar



SPECIFICATIONS: FOAM SYSTEMS: AQUIS™ 3.0

PERFECT BLEND OF PERFORMANCE AND VALUE

Each System Includes:

Foam Pump

Consists of an electric motor, positive displacement triplex plunger pump and control box mounted on a bracket.

Electric Motor:

1/2 HP (.4 kW) 12 or 24 volt. Protected with an electrical load circuit breaker of 80 amps for 12 VDC and 50 amps for 24 VDC.

Pump Rating:

3.0 GPM @ 150 psi (11.5 L/min @ 10 bar) with intermittent operating pressures up to 450 psi (31 bar).

Pump Construction:

Equipped with an anodized aluminum crankcase, oversized ball bearings, forged brass pump body and manifold, solid ceramic plungers, stainless steel inlet and delivery valves and piston guides. Buna packing and preset pressure regulating valve.

Control Box:

Microprocessor Controller:

A 16-bit mixed signal microcontroller with a 60 kB flash memory, 2kB RAM and 12-bit analog to digital convertor. Receives flowmeter flow rate and operator specifications through the OIT and provides the necessary voltage to the pump motor driver.

Pump Motor Driver:

Receives signals from the microprocessor controller and powers the electric motor in a variable speed duty cycle to ensure the correct amount of foam concentrate set by the operator is injected into the water stream.

AQUIS™ 3.0 FOAM PROPORTIONING SYSTEM

Operator Interface Terminal (OIT) Digital Operation

Installed on the pump operator's panel and provides the following functions:

Push button control of foam proportioning rates:

Class A concentrate: .1% to 1% in increments of .1%

Class B concentrate: 1%, 3% or 6%

Calibration of water flow rate.

Adjustable units of measurement.

Simulated water flow.

Optional lockout.

Warning of low foam concentrate supply:

Flashes and the displays a steady "low concentrate" warning when the concentrate tank runs low. Note that system will shut down after two minutes.

Flashes a "no concentrate" warning when the concentrate tank is empty.

Warning of an electronic malfunction:

Flashes and "error" warning when the concentrate tank is empty.

If apparatus has dual foam concentrate tanks, allows selection of tank A or B and displays which tank is in use.

Operation in manual mode as a backup.

A separate panel plate with operation instructions is furnished.

Remote Activation

Allows Foam Pump to be activated from an external 12 or 24 volt electrical source such as pump-in gear circuit or engine ignition power which eliminates a step in the foam system operation sequence.

Flowmeter and Tee

Installed in the water line from the fire pump.

Consists of a paddlewheel type flowmeter installed a brass tee which communicates water flow rate to the microprocessor in the foam pump control box.

The brass tees have an external Victaulic groove connection and internal female NPT connection on each end and are available in the following sizes:

1.50 in. Inside Diameter (300 GPM / 1135 L/min)

2.00 in. Inside Diameter (500 GPM / 1893 L/min)

2.50 in. Inside Diameter (750 GPM / 2800 L/min)

3.00 in. Inside Diameter (1250 GPM / 4700 L/min)

Cables and Wires

Separate industry standard M12 connectors for connection of OIT and flowmeter to foam pump control box. Consists of shielded cables to prevent radio frequency or electro-mechanical interference. Furnished as follows:

OIT connection to control box: 6 meters long

Flowmeter connection to control box: 3 meters long

Foam concentrate tank level switch to foam pump control box: 4 meters long

Note that foam tank level switches are optional from Waterous

Foam Concentrate Supply Line Strainer

Installed in the foam concentrate supply line and screens out any concentrate contamination which may harm the foam pump.

Consists of a 3/4 in. inline wye type brass strainer with a removable screen.



A Safe Fleet Brand



PRESSURE GOVERNOR and ENGINE MONITORING MODEL: PBA400



FIRE RESEARCH CORPORATION

www.fireresearch.com

26 Southern Blvd., Nesconset, NY 11767

TEL 631.724.8888 FAX 631.360.9727 TOLL FREE 1.800.645.0074



Soft-Glo Series Tank Level Gauges



J1939 CAN BUS TANK LEVEL MONITORING WITHOUT EYE IRRITATION

The Innovative Controls Inc. Soft-Glo Series Tank Level Gauge System is the next generation in a long line of reliable IC systems.

Soft-Glo utilizes IC's highly reliable pressure transducer to accurately measure tank volume and deliver tank level information to the viewer in a revolutionary way.

The display modules are divided into four distinct sections that show the volume of Water or Class A Foam or Class B Foam in the tank using multi-color RGB superbright LEDs. Tank level indication is enhanced by a 180° wide-angle diffusion lens in front of the LEDs. The LEDs are diffused by a proprietary method that creates an illumination effect that remains bright and visible in sunlight but eliminates the typical irritation to an operator's eyes traditionally caused by bright LEDs at night.

IC Soft-Glo displays are available in various sizes and treatments: pump panel main displays, in-cab mini displays and mini monster strip lights. Each display is available in multiple color, icon and bezel options designed to designate the display as either a Water, Foam A, Foam B, or Generic Foam display.

FEATURES

- Soft-Glo diffused lens eliminates hot spots
- 4 level display
- Can be accurately calibrated for any shape tank
- 180 degree viewing angle
- Multiple user-selectable color schemes
- Highly accurate, highly reliable pressure sensor
- Automatic dimming or fixed brightness levels
- Many bezel and labelling options
- Adjustable alarm or auto tank fill control output
- J1939 CAN-based communication
- -40C to +85C (-40F to +185F) operating temperature
- Protection against reverse power polarity
- 12VDC to 24VDC operation

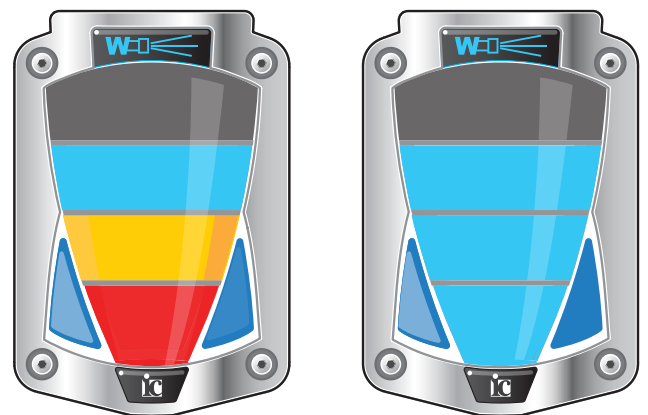

Multiple user-selectable color schemes

Whelen's new Freedom IV Series features advanced Linear Super-LED optics, DYAD™ two level technology, and 360° of contiguous light. The Freedom IV Rota-Beam™ lightbar is designed without any moving parts or motors, for long life reliability.

W E C A N X™



FEATURES

- **New** WeCanX™ models available
- Extruded aluminum platform for long life dependability
- Clear outer domes with clear dividers
- Available in permanent mount with passenger side cable exit or mode specific driver side option
- Color domes for center and end sections with optional alley window
- Alley and take-down light options
- Hard-coated lenses minimize environmental damage from sand, salt, sun, and road chemicals
- 100% solid-state electronics
- 12 VDC
- SAE Class 1 Certified
- Dimensions without mounting feet: 3.75" (95mm) H, 12.5" (318mm) W
- Five year warranty

FREEDOM IV DYAD

- WeCan[®] DYAD two level technology (single or two color) allows for individual control of each level of each lighthouse
- Low Current DYAD two level technology (single color) allows for individual control of each lighthouse segment (2x2)

- Linear Super-LED technology
- Advanced Thermal Design reduces the stress on LEDs during extended dwell time
- Optional Photocell automatically dims the lightbar at night while still meeting
- SAE Class 1 requirements
- Center dividers with LIM (Liquid Injection Molded) seals protect internal components from water infiltration
- Alternate center options available
- Each model has one or two sealing points, assuring lightbar integrity in all weather conditions
- Point to point wiring between the I/O board and each lighthouse allows for easy reconfiguration
- Newly designed corner modules blend light together for 360° of contiguous light
- Whelen's Collimator™ patented opti design provides unbeaten light output
- WeCan models are programmable with unlimited flash patterns
- Plug & Play into Whelen or vehicle manufactured controllers (WeCan only)

- Add up to 16 optional Linear Super-LED directional modules
- Go undercover with all new, SAE Class 1 Certified Smoked lenses and dividers or color domes
- Standard lengths: 44.5" (113cm), 49.75" (126cm), 55" (140cm), 60" (152cm), and 72" (183cm)

FREEDOM IV ROTA-BEAM

- Rotating Super-LED Technology
- Single color corner modules available in Amber, Blue, Red, or White
- Freedom IV F4R Rota-Beam Series Super-LED Lightbars, includes four half corner Super-LED beacons
- Multiple flash patterns
- Amp Draw: 2.2/average
- Standard lengths: 55" (139cm), 60" (152cm), and 72" (182cm)

MODELS

Model	Type	Color	Lens	Amp Draw
M6 Series with Internal Flasher & Synchronize Feature				
M6*	Warning	A, B, R, W	Color	Simultaneous: 2.2 peak, 0.9 average
M6*C		A, B, R	Clear	
M6#		Split R/W, R/B, R/A, A/W		
M6 Models requiring LED Flasher (purchased separately)				
M6*S	Warning	A, B, R, W	Color	Alternating: 1.1 peak, 0.45 average
M6*CS		A, B, R, W	Clear	
M6 Utility Lightheads				
M6BTT	Brake/Tail/Turn	R	Color	Brake/Turn - 0.85 average Tail - 0.06 average
M6T	Amber Turn Signal	A		0.75 average
M6BUW	Back-Up Light	W	Clear	1.6 average
M6ZC	Gradient Scenelight	W		2.0 average
M6 Series Options				Color
M6FC	Flange			Chrome
M6FB	Flange			Black
M6FCV2	Flange for 2 Lamps, Vertical			Chrome
M6FCV3	Flange for 3 Lamps, Vertical			
M6FCV4	Flange for 4 Lamps, Vertical			
M6FC600	Flange adapts M6 to 600 Series mounting			
M6HDLMTK	Headlight Mount Kit for ATI & KD with hardware			
M6BRUSH	Brush guard			
6BKT1	"L" Bracket Push Bumper Mount Kit			Black
6BKT2	Angled Bracket Push Bumper Mount Kit			
M6P15C	15° Angled Surface Mount Housing			Chrome
M6P15B				Black
M6PTM5F	Front Light Pod for 8 Lightheads, 2015-2018 Ford Transit, Medium Roof			Black, paintable to match vehicle
M6PT5R	Rear 2 Piece Light Pod for 6 Lightheads, 2015-2017 Ford Transit, Medium or High Roof			
M6PTH5F	Front Light Pod for 8 Lightheads, 2015-18 Ford Transit, High Roof			
M6WLENX	Replace Clear Lens with a Smoked Lens, M6 Warning Models Only			



M6 Series

- Solid color models have 159 Scan-Lock™ flash patterns
- Split color models have 64 Scan-Lock flash patterns
- Available in warning, brake/tail/turn, turn, back-up, and scene light models
- Front or rear lighbar pods house multiple M6 lightheads for the 2015-2018 Ford Transit Medium or High Roof
- Size with flange: 4.31" (109mm) H x 1.40" (36mm) D x 6.70" (170mm) L



M7 Series

- Solid color models have 159 Scan-Lock flash patterns
- Split color models have 64 Scan-Lock flash patterns
- Available in warning & Scenelight models
- Size with flange: 3.38" (86mm) H x 1.40" (36mm) D x 7.64" (194mm) L



M7ZC



WARNING: These products may contain chemicals known to the State of California to cause cancer and birth defects or other reproductive harm. For more information, visit whelen.com/regulatory.

MODELS

Model	Type	Color	Lens	Amp Draw
M7 Series with Internal Flasher & Synchronize Feature				
M7*	Warning	A, B, R, W	Color	Simultaneous: 2.5 peak, 0.9 average
M7*C		A, B, R	Clear	
M7#		Split R/W, R/B, R/A, A/W		
M7 Models requiring LED Flasher (purchased separately)				
M7*S	Warning	A, B, R, W	Color	Alternating: 1.125 peak, 0.45 average
M7*CS		A, B, R, W	Clear	
M7 Utility Lightheads				
M7ZC	Gradient Scenelight	W	Clear	2.25 average
M7 Series Options				Color
M7FC	Flange			Chrome
M7FB	Flange			Black
M7FC700	Polished Aluminum Flange			Chrome
M7BRUSH	Brush guard			Black
M7BKT1	Universal Mounting Bracket for one light			
M7WLENX	Replace Clear Lens with a Smoked Lens, for M7 Warning Models only			

Replace * symbol in model number with letter indicating color desired: A=Amber, B=Blue, C= Clear/White, R=Red
 Replace # symbol in model number with letter indicating split color desired:
 D=Red/White, E=Blue/White, F=Amber/White, J=Red/Blue, K=Red/Amber, M=Blue/Amber





MODELS

Model	Type	Color	Lens	Amp Draw	
M9 Series with Internal Flasher & Synchronize Feature					
M9*	Warning	A, B, R, W	Color	Simultaneous: 3.0 peak, 1.2 average Alternating: 1.2 peak, 0.6 average	
M9*C		A, B, R	Clear		
M9#	Warning, Side-By-Side	Split R/W, R/B, R/A			Clear
M9 Models requiring LED Flasher (purchased separately)					
M9*S	Warning	A, B, R, W	Color		
M9*CS		A, B, R, W	Clear		
M9 DUO™ Series, Scan-Lock, Low Power					
M92#	DUO Warning	R/B, R/W, B/A, B/W, A/W	Color	2.4 amps per color	
Combo Warning/Scenelight, Scan-Lock, Synchronize Feature & Hi/Low					
M9*CZ	Combination Warning/Scenelight	A/W, R/W, B/W, W/W	Clear	Warning - 1.58 average Scenelight - 1.53 average	
M9JCZ	DUO Combination Warning/Scenelight	R/B		Warning - 1.58 average per color Scenelight - 1.53 average	
M9 Utility Lightheads					
M9LZC	Scenelight, includes Flange	W	Clear	6.0 average	
M9BTTX	Brake/tail/turn	R	Color	Brake/Turn - 0.75 average Tail - 0.55 average	
M9T	Amber turn signal	A		1.2 average	
M9BUW	Back-up light	W	Clear	1.8 average	
M9LZC	Scenelight	W		6.0 average	
M9 Options	Description			Color / Type	
M9FC	Flange			Chrome	
M9FB	Flange			Black	
M9FC900	Flange adapts M9 Warning to 900 Series mount			Chrome	
M9FCZ900	Flange adapts M9 Scenelight to 900 Series mount			Chrome	
M9VFC900	Flange adapts M9V to 900 Series mount			Chrome	
M9BRUSH	Brush guard			Black	
M9WLENX	Replace Clear Lens with Smoked Lens, for M9 warning models Only			Smoked Lens	
M9HTM5FC	Front Driver and Passenger Side of the 2015-2018 Ford Transit Medium Roof, sold in pairs, lightheads purchased separately			Chrome-Plated Housing	
M9HTM5RC	Rear Driver and Passenger Side of the 2015-2018 Ford Transit Medium Roof, sold in pairs, lightheads purchased separately				
M9HTH5FC	Front Driver and Passenger Side of the 2015-2018 Ford Transit High Roof, sold in pairs, lightheads purchased separately				
M9HTH5RC	Rear Driver and Passenger Side of the 2015-2018 Ford Transit High Roof, sold in pairs, lightheads purchased separately				

M9 Series

- Solid color models have 159 Scan-Lock™ flash patterns
- Split color models have 64 Scan-Lock flash patterns
- Available in warning, brake/tail/turn, turn, back-up, and scenelight models
- Size with flange: 6.51" (165mm) H x 1.40" (36mm) D x 10.34" (263mm) L



M9BTTX



M9T



M9BUW



M9LZC



M9RCZ



M92E



M9JCZ



Replace * symbol in model number with letter indicating color desired: A=Amber, B=Blue, C= Clear/White, R=Red
 Replace # symbol in model number with letter indicating split color desired:
 D=Red/White, E=Blue/White, F=Amber/White, J=Red/Blue, K=Red/Amber, M=Blue/Amber



WARNING: These products may contain chemicals known to the State of California to cause cancer and birth defects or other reproductive harm. For more information, visit whelen.com/regulatory.

WHELEN

51 Winthrop Road
 Chester, Connecticut 06412-0684
 (860) 526-9504 www.whelen.com

Whelen Engineering reserves the right to upgrade and improve products without notice.
 © 2019 Whelen Engineering Company, Inc. Printed in U.S.A.
 NASCAR® is a registered trademark of the National Association for Stock Car Auto Racing, Inc.
 Code No. 12177Q - 09/03/2019

WHELEN

OFFICIAL WARNING LIGHTS



All products proudly designed, manufactured,
 and assembled in the U.S.A.
 • ISO 9001 Registered QMS

M9 EZ Scene Light™



M92SLC

The M9 EZ Scene Light features expanded zone efficiency, enhanced optics, and increased functionality to provide a powerful scene lighting solution for every situation. Plus, select from multiple turn-on styles and low-power settings for more efficient lighting output and performance. M Series lightheads feature a unique lens shape and patented Linear-LED® reflector assembly for unmatched high-intensity illumination with low current consumption.

The M9 EZ's dynamic functionality lets you shine the light where you need it the most.

FEATURES

- Redesigned optic aesthetics, light output, and light pattern optimizes light dispersion
- Gradient Opti-Scenelight™ technology enables efficient use of light
- Hard-coated lenses minimize environmental damage from sand, sun, salt, and road chemicals
- Selectable turn-on functionality
 - Multiple turn-on styles ranging from instant to gradual (Slow, Medium, Fast, Instant)
 - Three low-power settings provide situation-specific lighting for a variety of scenarios
- Surface mount
- Includes a 6" pigtail

SPECS

- Voltage: 12VDC or 24VDC
- Amps: 9.0 Amps at 12VDC
4.5 Amps at 24VDC
- Warranty: Lifetime warranty
- Dimensions: 2.63" D X 10.82" L X 8" H

M9 EZ Scene Light

M92SLC	White, Includes Chrome Flange, Slow Ramp Up, and Ramp to Low Power Features, 12VDC
M92SLB	White, Includes Black Flange, Slow Ramp Up, and Ramp to Low Power Features, 12VDC
M92SLC4	White, Includes Chrome Flange, Slow Ramp Up, and Ramp to Low Power Features, 24VDC
M92SLB4	White, Includes Black Flange, Slow Ramp Up, and Ramp to Low Power Features, 24VDC

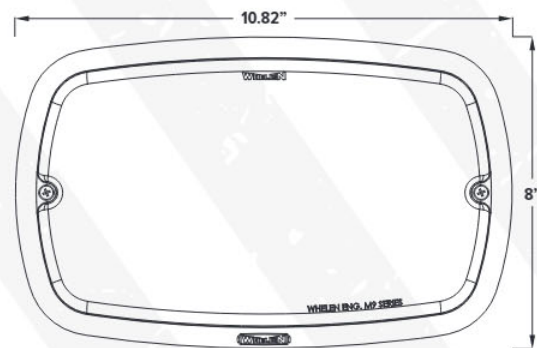

G291™ UNISTEEL® REGIONAL STEER/ALL-POSITION

GOODYEAR'S BEST REGIONAL ALL-POSITION TIRE FOR LONG MILES TO REMOVAL



VOCATION



RV & Coach



Emergency



Construction

WHEEL POSITION(S)



PROVEN TREAD COMPOUNDS balance fuel economy and mileage

SOLID 5-RIB TREAD DESIGN helps put more wearable rubber on the road for enhanced mileage

PREMIUM ENHANCED CASING helps provide toughness and durability for maximum retreadability

FOUR WIDE CIRCUMFERENTIAL GROOVES help deliver all-season traction on wet, snowy or dry roads

Complementary Products

DRIVE
Endurance® TSD

Competitive Replacements

Bridgestone M860A Michelin XZA2 Energy

TIRE SIZE	LOAD RANGE		SINGLE INFLATION		DUAL LOAD		DUAL INFLATION		WEIGHT		RIM WIDTH		OVERALL WIDTH		OVERALL DIAMETER		STATIC RADIUS		RPM	RPA	TREAD DEPTH 32/10S	MIN. DIAL SPACING		SPEED RATING
	LBS	KG	PSI	MPA	LBS	KG	LBS	KG	IN	MM	IN	MM	IN	MM	IN	MM	IN	MM						
315/80R22.5 J	8,270	3,750	120	830	7,610	3,450	120	830	132	60	9.00	12.4	315	42.3	1,074	19.7	500	491	305	18	13.8	351	75	
315/80R22.5 L	9,090	4,125	130	900	8,270	3,750	130	900	132	60	9.00	12.4	315	42.3	1,074	19.7	500	491	305	18	13.8	351	68	

Check goodyeartrucktires.com for updated data.



SPECIAL DELIVERY

G622 RSD[®]

THE GOODYEAR[®] G622 RSD — FOR REGIONAL AND LOCAL HIGH-SCRUB APPLICATIONS

The G622 RSD is a long-lasting tire ideal for regional and local high-scrub applications. Get outstanding traction from a tire that can hold up under tough conditions — and help your fleet save money. Additionally, the speed rating for the size 225/70R19.5 Load Range G G622 RSD has now been updated from 75 mph to 87 mph.

GOODYEAR
MORE DRIVEN.



G622 RSD®

The G622 RSD is available in the following sizes and load ranges:

Tire Size	Load Range	Single Load		Single Inflation		Dual Load		Dual Inflation		Weight		Rim Width		Overall Width		Overall Diameter		Static Radius		RPM	RPK	Tread Depth		Min. Dual Spacing		Speed Rating
		lbs	kg	psi	kpa	lbs	kg	psi	kpa	lbs	kg	in	in	mm	in	mm	in	mm	in			mm	in	mm		
TUBELESS TIRES ON 15" DROP CENTER RIMS																										
225/70R19.5	F	3,640	1,650	95	660	3,415	1,550	95	660	63	28	6.75	8.9	226	32.4	824	15.1	384	641	398	19	10.0	254	75		
225/70R19.5	G	3,970	1,800	110	760	3,750	1,700	110	760	65	29	6.75	8.9	226	32.4	824	15.1	384	641	398	19	10.0	254	87		
245/70R19.5	G	4,540	2,060	110	760	4,410	2,000	110	760	75	34	7.50	9.7	245	33.5	852	15.6	397	620	389	19	11.0	280	75		
10R22.5	G	5,675	2,575	115	790	5,355	2,430	115	790	112	51	7.50	10.2	259	40.6	1,031	19.0	483	512	318	23	11.4	290	75		
11R22.5	H	6,610	3,000	120	830	6,005	2,725	120	830	128	58	8.25	11.1	282	42.0	1,067	19.7	500	497	309	26	12.5	318	75		
12R22.5	H	7,390	3,350	120	830	6,780	3,075	120	830	139	63	9.00	11.7	297	43.3	1,100	20.3	516	482	300	22	13.5	343	75		
255/70R22.5	H	5,510	2,500	120	830	5,070	2,300	120	830	96	44	7.50	10.0	254	37.0	940	17.3	439	561	349	23	11.3	287	81		
245/75R22.5	G	4,675	2,120	110	760	4,410	2,000	110	760	94	43	7.50	9.6	244	37.6	955	17.7	450	552	343	23	11.0	279	75		
265/75R22.5	G	5,205	2,360	110	760	4,805	2,180	110	760	102	47	7.50	10.0	254	38.9	988	18.3	465	561	349	23	11.6	295	75		
295/75R22.5	G	6,175	2,800	110	760	5,675	2,575	110	760	118	54	8.25	11.2	284	40.8	1,036	19.1	485	512	318	26	12.9	328	75		
11R24.5	G	6,610	3,000	105	720	6,005	2,725	105	720	135	61	8.25	11.1	282	43.9	1,115	20.6	523	475	295	26	12.5	318	75		

Check goodyeartrucktires.com for updated data.



- AGGRESSIVE BLADING helps provide outstanding traction
- TIE-BARRED SHOULDERS enhance handling and help deliver even wear
- INCREASED WEARABLE TREAD RUBBER helps enhance mileage
- UNISTEEL® CONSTRUCTION enhances toughness and retreadability

Matching Retreads

Retreads	Size	Available Width		Tread Depth
		in	mm	32nds
UniCircle®	225/70R19.5	7½	190	19
UniCircle	245/70R19.5	8½	215	20
UniCircle	11R22.5	8½, 9	215, 230	26
UniCircle	295/75R22.5	8½, 9	215, 230	26
UniCircle	11R24.5	8½	215	26
Precure	-	7, 7½, 8, 8½, 8¾, 9¼	180, 190, 205, 215, 225, 235	22
Precure LT		7, 7½, 8, 8½*	180,* 190,* 205,* 215*	16

*Tread design also available with sipes.



To see how premium Goodyear® tires like the G622 RSD can help your fleet save money, call 1.866.FleetHQ or go to goodyeartrucktires.com

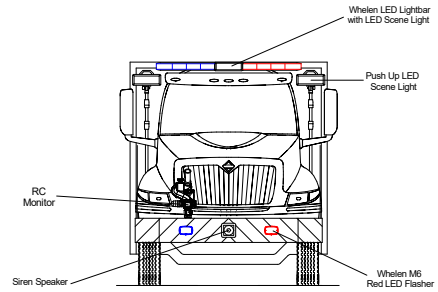
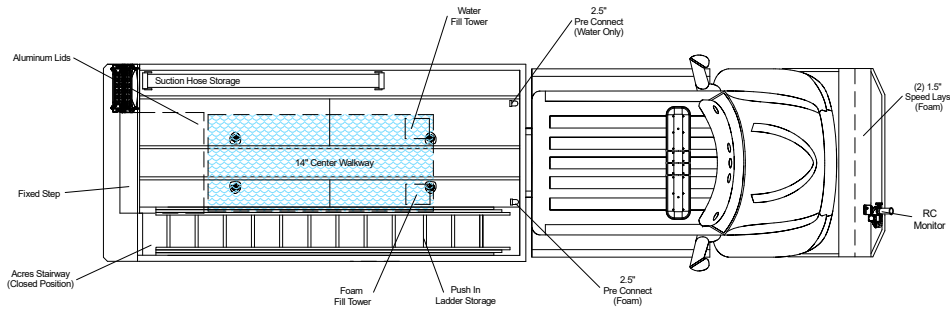

Cabinet Dimensions					
Cabinet Location	Door Opening Height	Width	Cabinet Size (Outside)		
			Height	Width	Depth
L1	61	37	71	42	12
L2	61	39	71	44	24
L3	31	54	41	56	24
L4	61	39	71	44	24
R1	61	37	71	42	12
R2	61	39	71	44	24
R3	31	54	41	56	24
R4	61	39	71	44	24
B1	61	48	71	50	33

NOTE:
All measurements stated herein are approximate and may vary slightly in production.

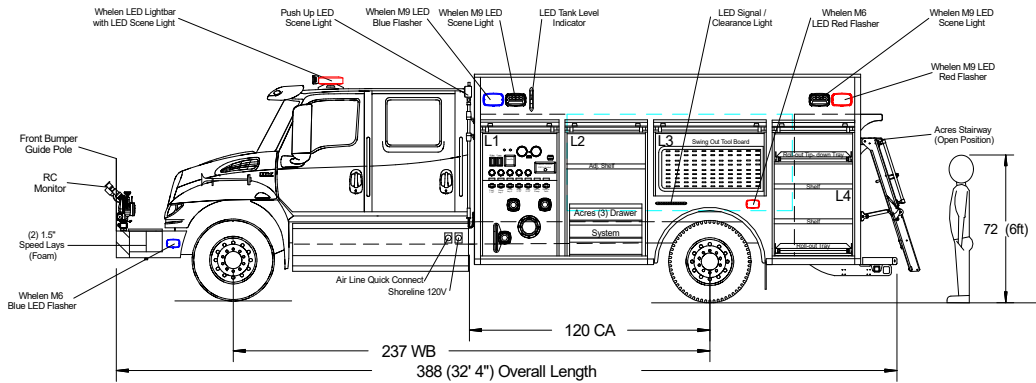
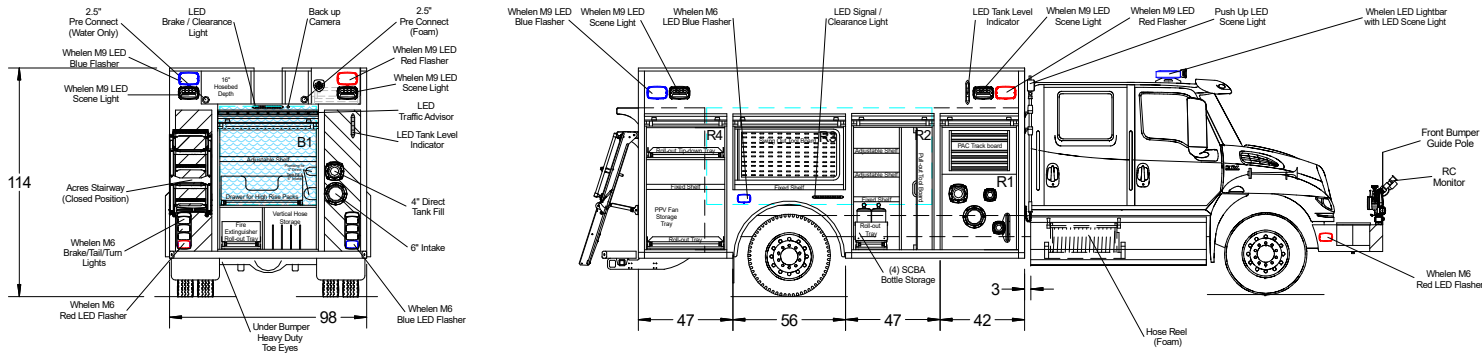

Approval Drawing

Customer: _____
 P.O. Number: _____
 Approved By: _____
 Date: _____

Revision: _____



ACRES INDUSTRIES INC. The information contained in this drawing is the sole property of Acres Industries Inc. Any reproduction in part or in whole without the written permission of Acres Industries Inc. is prohibited.
 P.O. Box 279 Wawanesa, Manitoba, Canada
 Phone: 204 824 2392 Fax: 204 824 2761
 Customer: _____
 Description: **FTL 4D RANGE 800IG**
 Model: **1929498**
 Scale: To Fit Page Date: May 10, 2023 Drawn By: JH
 Drawing Number: P***** Page: 1 of 1