



Van Diepenbeek Municipal Drain 2023

September 15, 2023

Prepared for:



Headway Engineering
23-500 Fairway Road South
Suite 308
Kitchener, Ontario N2C 1X3
226 243 6614
www.headwayeng.ca

Kitchener, Ontario
September 15, 2023

To the Mayor and Members of Council:

**Re: Van Diepenbeek Municipal Drain 2023
Township of Huron-Kinloss
Our Reference No. HK-004**

Headway Engineering is pleased to provide its report for the Van Diepenbeek Municipal Drain in the Township of Huron-Kinloss (Huron Ward).

The preparation of this report was authorized by a resolution of the Council of the Township of Huron-Kinloss on May 16, 2022, per Section 78 of the Drainage Act.

The primary objective of this report is to improve 'B' Drain and part of the Main Drain (Closed) on the Van Diepenbeek Municipal Drain by increasing the design capacity to today's standards of drainage. The report recommends the construction of an improved closed municipal drain from the east part of Lot 17, Concession 1, downstream to its outlet into the open portion in Lot 21, Concession 1, Huron Ward. Improvements to two culverts on the open portion of Van Diepenbeek Drain are also required.

A summary of the assessments for this project are as follows:

Municipal Lands	\$56,467
Privately Owned Agricultural - Grantable	\$133,934
Privately Owned - Non-Grantable	\$191,699
Total Estimated Assessments	\$382,100

Yours truly,

Stephen Brickman, P.Eng.
Project Engineer and Manager



Adam Hall
Project Coordinator
HEADWAY ENGINEERING
SB/





CONTENTS

1.0	INTRODUCTION AND LOCATION	1
2.0	PROJECT AUTHORIZATION.....	1
3.0	DRAINAGE HISTORY	1
4.0	PUBLIC MEETINGS AND ENGAGEMENTS	1
5.0	FINDINGS.....	2
6.0	DESIGN CONSIDERATIONS.....	3
7.0	ENVIRONMENTAL CONSIDERATIONS AND PERMITTING	4
8.0	RECOMMENDATIONS.....	4
9.0	SUMMARY OF PROPOSED WORKS.....	4
10.0	WORKING AREA AND ACCESS	5
11.0	SCHEDULES	5
12.0	ALLOWANCES.....	5
13.0	ESTIMATED CONSTRUCTION COSTS	6
14.0	SUMMARY OF ESTIMATED PROJECT COSTS	6
15.0	ASSESSMENT.....	7
16.0	GRANT ELIGIBILITY	8
17.0	ABANDONMENT OF EXISTING MUNICIPAL DRAINS.....	8
18.0	MAINTENANCE.....	8

SCHEDULES

SCHEDULE A – ALLOWANCES

SCHEDULE B – ESTIMATED CONSTRUCTION COSTS

SCHEDULE C – ASSESSMENT FOR CONSTRUCTION

SCHEDULE D – ASSESSMENT FOR FUTURE MAINTENANCE

SPECIFICATIONS FOR THE CONSTRUCTION OF MUNICIPAL DRAINAGE WORKS

1.0 INTRODUCTION AND LOCATION

The Council of the Township of Huron-Kinloss has appointed Headway Engineering under Section 78 of the Drainage Act to investigate improvements to be made to the Van Diepenbeek Drain. The project services parts of Lots 11 to 26, Concession 1 in the Township of Huron-Kinloss, Bruce County.

The Drainage Area comprises of approximately 297 hectares, and land uses within the watershed include agricultural, bush lands and roads.

The attached Plans, Profiles and Details; Drawing Numbers 1 to 3, show and describe in detail the location and extent of the work to be completed and the lands which are affected.

2.0 PROJECT AUTHORIZATION

Authority to prepare this report was obtained by a resolution of the Council of the Township of Huron-Kinloss at its May 16, 2022, meeting to appoint Headway Engineering under Section 78 of the Drainage Act.

3.0 DRAINAGE HISTORY

3.1 Van Diepenbeek Municipal Drain (1969)

The lands affected by this report (2023) are within the watershed of the Van Diepenbeek Municipal Drain which was originally constructed under the authority of a report prepared by H. M. Gibson, dated December 2, 1969. This 1969 report provided for the construction of 16 closed tile systems and improvements to the open portion. 'B' Drain was incorporated in this report.

4.0 PUBLIC MEETINGS AND ENGAGEMENTS

4.1 On-Site Meeting

In accordance with Section 9(1) of the Drainage Act, an on-site meeting was held on July 12, 2022. Persons in attendance were:

Stephen Brickman, P.Eng.	Headway Engineering
Adam Hall	Headway Engineering
Ken McCallum	Township of Huron-Kinloss, Drainage Superintendent
Emily Dance	Township of Huron-Kinloss, Clerk

Landowners included:

Bruce Scott	Mary Scott	Harry Van Diepenbeek
David Gibson		

A preliminary plan showing the watershed was distributed in advance. The information provided was based on previous engineering reports, and data made available to the public by the Province of Ontario.

4.2 Public Information Meeting

A Public Information Meeting was held on April 27, 2023. Persons in attendance were:



Stephen Brickman, P.Eng.	Headway Engineering
Adam Hall	Headway Engineering
Ken McCallum	Township of Huron-Kinloss, Drainage Superintendent
Kelly Lush	Township of Huron-Kinloss, Deputy Clerk

Landowners included:

Bruce Scott	Mary Scott	Bert Von Westerholt
David Gibson		

The information provided included details on the proposed construction of an improved tile drainage system on an alignment similar to the existing drain. The replacement of two farm crossings were also included in the proposal.

This meeting provided a review of the design of the proposed drainage system, the estimated costs of the project, and the proposed assessments.

5.0 FINDINGS

Based on the information collected during field investigations, surveys, public engagements, and review of documentation, the following summarizes Headway Engineering's findings:

5.1 Watershed Condition (Hydrology):

- The watershed was established through the analysis of tile drainage maps, previous engineers' reports for surrounding systems, field investigations, surveys, and data analysis of the Southwestern Ontario Orthophotographic Project (SWOOP). The drainage area comprises of approximately 297.4 hectares.
- Land uses within the watershed are as follows:
 - Agricultural: 268.3 hectares (90%)
 - Bush: 23.4 hectares (8%)
 - Residential: 1.6 hectares (1%)
 - Roads: 4.1 hectares (1%)
- Improved farm tiling has recently taken place within the watershed, and it can be anticipated that additional farm tiling will occur in the future.
- The Ontario Ministry of Agriculture, Food and Rural Affairs' Agricultural Information Atlas describes the soil types within the watershed and along the route of the drain as follows:
 - Clay Loam (73%)
 - Loam (19%)
 - Sandy Loam (8%)

5.2 Existing Drainage System:

- This report focuses on improving 'B' Drain and the Main Drain (Closed) of the Van Diepenbeek Drain. The existing drainage system in the immediate area of the proposed work consists of 150mm to 450mm diameter pipes.
- The greater system includes a main drain and 16 branches.



- The drainage coefficient design standard for the existing drainage system (Main Drain (Closed) and 'B' Drain) is approximately 13mm per 24-hour period, as calculated by Headway Engineering.

5.3 Outlet:

- The Van Diepenbeek Main Drain (Open) is of sufficient depth to adequately drain the upstream lands.

5.4 Other noted issues:

- The existing 'B' Drain and Main Drain (Closed) are not of sufficient capacity nor depth to drain the surrounding and upstream lands within the watershed at today's standards of drainage.
- Frequent blowouts are occurring along 'B' Drain due to insufficient capacity and poor condition of the existing drain.
- The existing road crossing configuration at Sideroad 10 South is poor.

5.5 Environmental Requirements:

- The Maitland Valley Conservation Authority (MVCA) has indicated that a permit to alter a watercourse is required.

6.0 DESIGN CONSIDERATIONS

The proposed drainage system is sized using the Drainage Coefficient method contained in the OMAFRA Publication 29 - 'Drainage Guide for Ontario'. The Drainage Coefficient describes a depth of water to be conveyed by the drainage works per a 24-hour period and is expressed in millimeters per 24 hours. The drainage coefficient design standard used for the works proposed in this report is 38mm per 24-hour period.

The drain is to be installed along the existing alignment of 'B' Drain and the lower portion of the Main Drain (Closed) on the Van Diepenbeek Municipal Drain. An alternative alignment was considered to shorten the distance between the upper end of 'B' Drain and the open ditch. Although the alternative alignment had marginally reduced construction costs, it would result in land being lost due to significant deepening of the open portion of the 'A' Drain and provide for fewer legal outlets. The preferred alignment is much more practical.

Pipe materials were selected based on location and intended land uses adjacent to the drainage system.

Surface water inlets have been placed purposefully to receive surface flow and allow for subsurface tile connections. Likewise, the elevation of the pipe system is designed to provide for subsurface tile connections at, and between surface water inlets.



7.0 ENVIRONMENTAL CONSIDERATIONS AND PERMITTING

7.1 Department of Fisheries and Oceans (DFO)

The work proposed under this report primarily consists of the new construction of a closed drainage system. There are minimal in-water works proposed or required. Therefore, the works do not cause death of fish, permanent alteration, or destruction of fish habitat. Likewise, DFO's participation is not required.

7.2 Ministry of Natural Resources and Forestry (MNR) and the Ministry of Environment, Conservation & Parks (MECP)

Headway Engineering completed a review of the Natural Heritage Information Centre (NHIC) mapping for Species at Risk in Ontario. The NHIC mapping indicates that there is a possibility of Eastern Meadowlark in the working area. Although Eastern Meadowlark was not observed, special provisions to locate the species (if present) within the work area will be included in the contract documents for construction.

7.3 Maitland Valley Conservation Authority (MVCA)

The MVCA has been included on the circulation list for this report and has been invited to all public engagements. Headway Engineering has forwarded design discussions and drawings to the MVCA on September 14, 2023.

The MVCA has indicated that a permit to alter a watercourse is required.

8.0 RECOMMENDATIONS

Headway Engineering recommends the following:

1. A new municipal drainage system be installed from the outlet in Lot 21, Concession 1 to the east side of Lot 17, Concession 1.
2. The proposed drainage system includes the installation of approximately 1,496m of 450mm to 600mm diameter pipes and is designed to convey flows at a design standard of 38mm per 24-hour period.
3. The proposed tile drain alignment shall be approximately parallel to the existing drainage system.
4. The proposed drainage system shall be installed at an elevation adequate to drain the subsurface lands within the watershed.
5. The existing drainage system being replaced shall be destroyed.
6. The replacement of two farm culverts with larger diameter pipes on the Main Drain (Open).
7. This new drainage system shall be known as the **Van Diepenbeek Municipal Drain 2023**.
8. Headway Engineering also recommends that the watersheds of the surrounding municipal drains be updated when those drainage systems are revisited in the future.

9.0 SUMMARY OF PROPOSED WORKS

The proposed work consists of:



1. The installation of approximately 1,496m of 450mm to 600mm diameter concrete field tile and HDPE pipe,
2. The replacement of two new culverts,
3. The installation of three concrete catch basins and one junction box.

10.0 WORKING AREA AND ACCESS

Access to the working area shall be designated by the Landowners.

The working area shall be an average width of 25m for construction purposes, and an average width of 10m for maintenance purposes along the alignment of the proposed drain.

11.0 SCHEDULES

Four schedules are attached and form part of this report.

11.1 Schedule A – Schedule of Allowances

In accordance with Sections 29 and 30 of the Drainage Act, allowances are provided to Landowners for Right-of-Way and Damages to Lands and Crops. Schedule A contains a table of the applicable allowances to Landowners.

11.2 Schedule B – Schedule of Estimated Construction Costs

An itemized cost estimate of the proposed construction work is included in detail in Schedule B.

11.3 Schedule C – Schedule of Assessment for Construction

Schedule C provides details of the distribution of the total estimated costs of the construction of the municipal drain.

11.4 Schedule D – Schedule of Assessment for Future Maintenance

Schedule D provides details of the distribution of future maintenance costs for the municipal drain. Maintenance assessments are expressed as a percentage of the total maintenance. Lands located upstream of the maintenance shall be determined by the Drainage Superintendent and assessed according to this schedule.

12.0 ALLOWANCES

In accordance with Sections 29 and 30 of the Drainage Act, Allowances payable to Landowners are described below.

12.1 Allowances for Right-of-Way (Section 29)

The Right-of-Way allowance compensates the lands for the right to enter onto the land at various times for the purpose of inspecting the drainage system and conducting maintenance activities. The land value used for the Right-of-Way calculation is adjusted to account for the continued use of the land after the construction of the closed drainage system.

Right-of-way allowances were not provided to Landowners in the previous report prepared by H.M Gibson Ltd. Consulting Engineers, dated December 2, 1969.



The values used for calculating allowances for Right-of-Way are as follows:

Land Use	Land Value	Adjustment Factor for Drainage Act Right-of-Way	Adjusted Land Value for Drainage Act Right-of-Way Allowance
Agricultural workable land	\$60,000/Ha	25%	\$15,000/Ha

12.2 Allowances for Damages to Lands and Crops (Section 30)

Allowances for Damages to Lands and Crops under Section 30 of the Drainage Act, were primarily calculated to compensate landowners for crop losses, and land damages due to the construction and operation of the drain, including access to the working area.

It is anticipated that the working area will experience a complete crop loss in the year of construction, and a reduction in crop productivity for the following two years.

Area values used for calculating allowances for Damages are as follows:

Land Use	Damage Value
Agricultural workable land	\$6,000/Ha.

Allowances payable to Landowners are shown in Schedule A.

Total Allowances, under Sections 29 and 30 of the Drainage Act are \$47,280.

Allowances will be deducted from the total assessments in accordance with Section 62(3) of the Drainage Act.

13.0 ESTIMATED CONSTRUCTION COSTS

Headway Engineering has made an estimate of the cost of the proposed construction work. A detailed description of the construction costs can be found in Schedule B of this report.

Part A – Main Drain (Open)	\$ 40,000
Part B – Main Drain (Closed) & ‘B’ Drain	\$ 183,300
Part C – Provisional Items	\$ 18,700
Total Estimated Construction Costs	\$ 242,000

14.0 SUMMARY OF ESTIMATED PROJECT COSTS

The total estimated project costs are as follows:

Allowances under Sections 29 and 30 of the Drainage Act (Refer to Schedule A)	\$ 47,280
Total Estimated Construction Costs (Refer to Schedule B)	\$ 242,000



Public engagements, survey, design and drafting, preparation of preliminary cost estimates and assessments, preparation of final drainage report, consideration of report	\$ 51,700
Environmental Agency Consultations and Approvals, including permit fees	\$ 1,000
Tendering, Supervision, and inspection of construction, as-recorded drawing preparation	\$ 17,200
Contingencies, Interest and net H.S.T.	\$ 22,920
TOTAL ESTIMATED PROJECT COSTS	
VAN DIEPENBEEK MUNICIPAL DRAIN 2023	\$ 382,100

The estimated cost of the work in the Township of Huron-Kinloss is \$382,100.

The above costs are estimates only. The final costs of construction, engineering and administration cannot be determined until the project is completed.

The above cost estimate does not include costs associated with defending the drainage report should appeals be filed with the Court of Revision, Drainage Tribunal and/or Drainage Referee. Should additional costs be incurred, unless otherwise directed, the additional costs would be distributed in a pro-rata fashion over the assessments contained in Schedule C and as may be varied under the Drainage Act.

15.0 ASSESSMENT

Headway Engineering assesses the cost of this work against the Lands and Roads as shown in Schedule C - Assessment for Construction.

Assessments were determined using the principles included in the 'Drainage Assessment Revisited' paper prepared by E.P. Dries and H.H. Todgham. These principles of assessment are recognized to be fair and equitable for determining cost distributions among those affected.

15.1 Benefit (Section 22)

Benefit assessment is applied to those properties receiving a benefit as defined in Section 1 of the Drainage Act which is extracted below:

Benefit means the advantages to any lands, roads, buildings or other structures from the construction, improvement, repair, or maintenance of a drainage works such as will result in a higher market value or increased crop production or improved appearance or better control of surface or sub-surface water, or any other advantages relating to the betterment of lands, roads, buildings or other structures.

Typically, properties which have direct, or near direct access to the proposed drain receive Benefit as defined above.

15.2 Outlet Liability (Section 23)

Outlet Liability is distributed to all properties within the watershed area on an adjusted area basis. The areas are adjusted to accurately reflect equivalent run-off rates relative to other lands and



roads within the watershed. Due to development, roads have been assessed higher Outlet Liability rates relative to agricultural lands.

15.3 Special Assessment (Section 26)

Special Assessments apply to public utilities and roads which directly cause increased costs to the construction of a drainage works due to the existence and operation of the public utility or road.

Construction costs which are required solely because of the existence of Sideroad 10 South are fully assessed to the road authority having jurisdiction over the road. The Special Assessment is calculated based on the actual costs of the road crossing, plus an allowance for administration as described below.

Road Name	Construction Costs	Plus Administration Costs	Less Equivalent Drain Costs (Fixed)	Plus Interest, and Net HST	Special Assessment
Sideroad 10 South	\$20,880	\$7,010	\$2,540	\$490	\$25,840

Whether or not the Township of Huron-Kinloss elects to do the work on their property, Sideroad 10 South, they shall be assessed the actual increased costs of the work due to the construction and operation of the road as a Special Assessment.

16.0 GRANT ELIGIBILITY

The Province provides grants towards assessments to eligible properties for drainage improvements which meet specified criteria. The provision of these grants for activities under the Drainage Act is called the Agricultural Drainage Infrastructure Program (ADIP).

A grant may be available for assessments to privately owned parcels of land which are used for agricultural purposes and eligible for the Farm Property Class Tax rate. Section 88 of the Drainage Act directs the Municipality to make an application for this grant upon certification of completion. The Municipality will then deduct the grant from the assessments.

17.0 ABANDONMENT OF EXISTING MUNICIPAL DRAINS

In accordance with Section 19 of the Drainage Act, the works constructed and/or incorporated under the authority of the report prepared by prepared by H. M. Gibson, dated December 2, 1969 for the Main Drain (Closed) from Sta. 0+000 to Sta. 0+465, and for 'B' Drain, shall be abandoned and destroyed. All other works constructed in the previous report shall remain.

18.0 MAINTENANCE

After completion, the Van Diepenbeek Municipal Drain shall be maintained by the Township of Huron-Kinloss at the expense of all the lands and roads assessed in accordance with the attached Schedule D – Assessment for Future Maintenance, and in the same relative proportions until such time as the assessment is changed under the Drainage Act, except for the portions of the drainage works on municipal right-of-ways. These portions shall be maintained at the expense of the road authority having jurisdiction over the road.



Schedule A

Allowances

Schedule of Allowances

Van Diepenbeek Municipal Drain 2023

Main Drain (Open)	Property Details				Drainage Act Allowances		
	Part Lot	Concession	Landowner	Roll Number	Right of Way (Sec. 29)	Damages (Sec. 30)	Total Allowances
	22,23,24	1	Harry Van Diepenbeek	1-076	\$ -	\$ 1,000.00	\$ 1,000.00
	25,26	1	James Gibson	1-077	\$ -	\$ 1,000.00	\$ 1,000.00
Total Allowances							
Main Drain (Open)					\$ -	\$ 2,000.00	\$ 2,000.00

Main Drain (Closed) & 'B' Drain	Property Details				Drainage Act Allowances		
	Part Lot	Concession	Landowner	Roll Number	Right of Way (Sec. 29)	Damages (Sec. 30)	Total Allowances
	15,16	1	Bruce & Mary Scott	1-071	\$ -	\$ 1,000.00	\$ 1,000.00
17,18	1	Vererna Berghe Von Trips	1-073	\$ 6,000.00	\$ 6,000.00	\$ 12,000.00	
19,20	1	Vererna Berghe Von Trips	1-074	\$ 6,270.00	\$ 6,270.00	\$ 12,540.00	
21	1	Vererna Berghe Von Trips	1-075	\$ 9,870.00	\$ 9,870.00	\$ 19,740.00	
Total Allowances							
Main Drain (Closed) & 'B' Drain					\$ 22,140.00	\$ 23,140.00	\$ 45,280.00

				Drainage Act Allowances		
				Right of Way (Sec. 29)	Damages (Sec. 30)	Total Allowances
Total Allowances				\$ 22,140.00	\$ 25,140.00	\$ 47,280.00



Schedule B

Estimated Construction Costs

Schedule of Estimated Construction Costs

We have made an estimate of the cost of the proposed work which is outlined in detail as follows:

Part A - Main Drain (Open)

Description	Estimated Quantity	\$/Unit	Total
1) Clearing, brushing and mulching	l.s.		\$ 2,000.00
2) Supply 1800mm diameter CSP with 125x25mm corrugations, 2.8mm thickness, type II aluminized coating	12 m	\$ 1,000.00	\$ 12,000.00
Installation of 1800mm diameter CSP pipe complete with quarry stone rip-rap protection and geotextile filter material (25m ²) and including the removal and offsite disposal of existing CSP	l.s.		\$ 7,000.00
3) Supply 1800mm diameter CSP with 125x25mm corrugations, 2.8mm thickness, type II aluminized coating	12 m	\$ 1,000.00	\$ 12,000.00
Installation of 1800mm diameter CSP pipe complete with quarry stone rip-rap protection and geotextile filter material (25m ²) and including the removal and offsite disposal of existing CSP	l.s.		<u>\$ 7,000.00</u>
Total Estimated Construction Costs			<u>\$ 40,000.00</u>
Part A - Main Drain (Open)			<u>\$ 40,000.00</u>

Part B - Main Drain (Closed) & 'B' Drain

Description	Estimated Quantity	\$/Unit		Total
1) Construct quarry stone rip-rap lined outlet structure	I.s.		\$	5,004.00
2) Supply 600mm diameter HDPE (CSA B182.8) outlet pipe complete with rodent grate	6 m	\$ 155.00	\$	930.00
Installation (Sta. 0+000 to Sta. 0+006)	6 m	\$ 100.00	\$	600.00
3) Supply 600mm diameter concrete field tile	512 m	\$ 66.00	\$	33,792.00
Installation (Sta. 0+006 to Sta. 0+518)	512 m	\$ 45.00	\$	23,040.00
4) Supply 525mm diameter concrete field tile	642 m	\$ 52.00	\$	33,384.00
Installation (Sta. 0+518 to Sta. 0+659 & Sta. 0+679 to Sta. 1+180)	642 m	\$ 45.00	\$	28,890.00
5) Supply 450mm diameter concrete field tile	316 m	\$ 40.00	\$	12,640.00
Installation (Sta. 1+180 to Sta. 1+496)	316 m	\$ 40.00	\$	12,640.00
6) Supply and install 900mm x 1200mm concrete junction box at Sta. 0+465 (inline) including connecting the existing main drain	I.s.		\$	3,500.00
7) Supply and install 600mm x 600mm concrete catch basin (Inline) at Sta. 1+496	I.s.		\$	3,500.00
8) Destroy existing drain	I.s.		\$	4,500.00
Sub-Total - Work on Lands			\$	162,420.00

Description	Estimated Quantity	\$/Unit	Total
9) Work to be done on the Township of Huron Kinloss Road Allowance,			
a) Supply 525mm diameter HDPE pipe (CSA B182.8)	20 m	\$ 120.00	\$ 2,400.00
Installation of 525mm diameter HDPE by open cut method	l.s.		\$ 5,000.00
b) Supply 450mm diameter HDPE pipe (CSA B182.8)	16 m	\$ 155.00	\$ 2,480.00
Installation of 450mm diameter HDPE roadway surface pipe	l.s.		\$ 4,000.00
c) Supply and install 900 x 1200 concrete catch basin at Sta. 0+659 and Sta. 0+679	2 ea.	\$ 3,500.00	\$ 7,000.00
Sub-Total - Sideroad 10 South			\$ 20,880.00

Total Estimated Construction Costs

Part B - Main Drain (Closed) & 'B' Drain

\$ 183,300.00

Part C - Provisional Items

A Provisional Item is an item that may or may not be required as a part of the Contract. The decision as to whether a Provisional Item will form part of the Contract will be at the discretion of the engineer at time of construction. Payment for Provisional Items will only be made for work authorized in writing (text or email) by the Engineer. Payment for work performed under a Provisional Item shall be based on the Unit Price bid in the Scope of Work below.

- 1) Additional costs associated with installation of tile drain on 19mm diameter crushed clear stone bedding. This includes the supply and placement of all stone, and additional labour and equipment required for installation in accordance with the Typical Pipe Installation on wrapped Stone Bedding Detail.

Description	Estimated Quantity	\$/Unit	Total
450mm diameter pipe	50 m	\$ 65.00	\$ 3,250.00
525mm diameter pipe	50 m	\$ 75.00	\$ 3,750.00
600mm diameter pipe	50 m	\$ 75.00	\$ 3,750.00

- 2) Additional costs associated with installation of tile drain on 19mm diameter crushed clear stone bedding. This includes the supply and placement of all stone, and additional labour and equipment required for installation in accordance with the Typical Pipe Installation on Stone Bedding Detail (un-wrapped bedding).

Description	Estimated		
	Quantity	\$/Unit	Total
450mm diameter pipe	25 m	\$ 55.00	\$ 1,375.00
525mm diameter pipe	25 m	\$ 60.00	\$ 1,500.00
600mm diameter pipe	25 m	\$ 60.00	\$ 1,500.00

- 3) Wheel machine lift outs due to stony conditions 5 ea. \$ 305.00 \$ 1,525.00

- 4) Tile connections:

Description	Estimated		
	Quantity*	\$/Unit	Total
100mm diameter	10 m	\$ 90.00	\$ 900.00
150mm diameter	5 m	\$ 100.00	\$ 500.00
200mm diameter	5 m	\$ 130.00	\$ 650.00

*The Contractor shall be paid for the actual quantity of tile connections at the above fixed unit prices.

Total Estimated Construction Costs

Part C - Provisional Items

\$ 18,700.00

Summary of Estimated Construction Costs

Part A - Main Drain (Open)	\$ 40,000.00
Part B - Main Drain (Closed) & 'B' Drain	\$ 183,300.00
Part C - Provisional Items	\$ 18,700.00

Total Estimated Construction Costs

\$ 242,000.00

Total Estimated Materials	\$ 109,626.00
Total Estimated Labour and Equipment	\$ 132,374.00

Total Estimated Construction Costs

Van Diepenbeek Municipal Drain 2023

\$ 242,000.00



Schedule C

Assessment for Construction

**Schedule of Assessment for Construction
Van Diepenbeek Municipal Drain 2023**

	Property Details				Drainage Act Instruments of Assessment				For Information				
	Part Lot	Concession	Landowner	Roll Number	Approx. Ha. Affected	Benefit (Sec. 22)	Outlet Liability (Sec. 23)	Special Assessment (Sec. 26)	Total Assessment	Less Gov't Grant	Less Allowances	Net Estimated Expense	
Main Drain (Open)	11,12,13	1	Peter Schlegel	1-006	38.66	\$ -	\$ 1,877.00		\$ 1,877.00	*	\$ -	\$ 1,877.00	
	12,13	1	Tyler & Rachel Kernighan	1-068	8.89	\$ -	\$ 387.00		\$ 387.00	\$ 129.00	\$ -	\$ 258.00	
	14	1	Vererna Berghe Von Trips	1-008	13.3	\$ -	\$ 651.00		\$ 651.00	*	\$ -	\$ 651.00	
	14	1	Vererna Berghe Von Trips	1-069	10.1	\$ -	\$ 398.00		\$ 398.00	*	\$ -	\$ 398.00	
	14	1	Linda Taylor	1-070	10.1	\$ -	\$ 51.00		\$ 51.00	\$ 17.00	\$ -	\$ 34.00	
	15,16	1	Bruce & Mary Scott	1-071	50.67	\$ -	\$ 2,548.00		\$ 2,548.00	\$ 849.00	\$ -	\$ 1,699.00	
	16,17,18	1	Adam Miltenburg	1-010	17.53	\$ -	\$ 882.00		\$ 882.00	\$ 294.00	\$ -	\$ 588.00	
	17	1	Eugene & Sheila Zsiga	1-072	1.61	\$ -	\$ 120.00		\$ 120.00	*	\$ -	\$ 120.00	
	17,18	1	Vererna Berghe Von Trips	1-073	38.86	\$ -	\$ 1,954.00		\$ 1,954.00	*	\$ -	\$ 1,954.00	
	19,20	1	Vererna Berghe Von Trips	1-074	40.47	\$ -	\$ 2,035.00		\$ 2,035.00	*	\$ -	\$ 2,035.00	
	21	1	Vererna Berghe Von Trips	1-075	19.54	\$ -	\$ 983.00		\$ 983.00	*	\$ -	\$ 983.00	
	22,23,24	1	Harry Van Diepenbeek	1-076	39.3	\$ 20,565.00	\$ 958.00		\$ 21,523.00	\$ 7,174.00	\$ 1,000.00	\$ 13,349.00	
	25,26	1	James Gibson	1-077	4.42	\$ 20,565.00	\$ 220.00		\$ 20,785.00	\$ 6,928.00	\$ 1,000.00	\$ 12,857.00	
	Total Assessments on Lands						\$ 41,130.00	\$ 13,064.00	\$ -	\$ 54,194.00	\$ 15,391.00	\$ 2,000.00	\$ 36,803.00
	Sideroad 10 South		Township of Huron Kinloss		1.84	\$ -	\$ 370.00		\$ 370.00			\$ 370.00	
Concession 2		Township of Huron Kinloss		2.13	\$ -	\$ 536.00		\$ 536.00			\$ 536.00		
Total Assessments on Roads						\$ -	\$ 906.00	\$ -	\$ 906.00			\$ 906.00	
Total Assessments													
Main Drain (Open)						\$ 41,130.00	\$ 13,970.00	\$ -	\$ 55,100.00	\$ 15,391.00	\$ 2,000.00	\$ 37,709.00	

Main Drain (Closed) & 'B' Drain	Property Details					Drainage Act Instruments of Assessment				For Information		
	Part Lot	Concession	Landowner	Roll Number	Approx. Ha. Affected	Benefit (Sec. 22)	Outlet Liability (Sec. 23)	Special Assessment (Sec. 26)	Total Assessment	Less Gov't Grant	Less Allowances	Net Estimated Expense
	14	1	Vererna Berghe Von Trips	1-069	5.28	\$ -	\$ 4,772.00		\$ 4,772.00	*	\$ -	\$ 4,772.00
	14	1	Linda Taylor	1-070	10.1	\$ -	\$ 2,207.00		\$ 2,207.00	\$ 736.00	\$ -	\$ 1,471.00
	15,16	1	Bruce & Mary Scott	1-071	21.86	\$ 37,786.00	\$ 47,765.00		\$ 85,551.00	\$ 28,517.00	\$ 1,000.00	\$ 56,034.00
	17	1	Eugene & Sheila Zsiga	1-072	1.61	\$ -	\$ 2,129.00		\$ 2,129.00	*	\$ -	\$ 2,129.00
	17,18	1	Vererna Berghe Von Trips	1-073	15.75	\$ 52,960.00	\$ 25,212.00		\$ 78,172.00	*	\$ 12,000.00	\$ 66,172.00
	19,20	1	Vererna Berghe Von Trips	1-074	11.94	\$ 47,314.00	\$ 11,492.00		\$ 58,806.00	*	\$ 12,540.00	\$ 46,266.00
	21	1	Vererna Berghe Von Trips	1-075	8.89	\$ 33,890.00	\$ 5,912.00		\$ 39,802.00	*	\$ 19,740.00	\$ 20,062.00
	Total Assessments on Lands					\$ 171,950.00	\$ 99,489.00	\$ -	\$ 271,439.00	\$ 29,253.00	\$ 45,280.00	\$ 196,906.00
	Sideroad 10 South	Township of Huron Kinloss			1	\$ 12,540.00	\$ 2,416.00	\$ 25,840.00	\$ 40,796.00			\$ 40,796.00
	Concession 2	Township of Huron Kinloss			1.99	\$ -	\$ 14,765.00		\$ 14,765.00			\$ 14,765.00
	Total Assessments on Roads					\$ 12,540.00	\$ 17,181.00	\$ 25,840.00	\$ 55,561.00			\$ 55,561.00
	Total Assessments Main Drain (Closed) & 'B' Drain					\$ 184,490.00	\$ 116,670.00	\$ 25,840.00	\$ 327,000.00	\$ 29,253.00	\$ 45,280.00	\$ 252,467.00

	Drainage Act Instruments of Assessment Summary				For Information		
	Benefit (Sec. 22)	Outlet Liability (Sec. 23)	Special Assessment (Sec. 26)	Total Assessment	Less Gov't Grant	Less Allowances	Net Estimated Expense
Total Assessments Van Diepenbeek Municipal Drain 2023	\$ 225,620.00	\$ 130,640.00	\$ 25,840.00	\$ 382,100.00	\$ 44,644.00	\$ 47,280.00	\$ 290,176.00

- Notes:
- 1 '*' Denotes Lands not eligible for ADIP Grants.
 - 2 The Special Assessments (Sec. 26) shall be a non-proratable assessment. All other assessments are proratable.
 - 3 The Net Estimated Expense is the Total Assessment less gov't grants and allowances (if applicable).

**Schedule of Assessment for Construction
Van Diepenbeek Municipal Drain 2023**

	Property Details					Summary of Assessment			For Information			
	Part Lot	Concession	Landowner	Roll Number	Approx. Ha. Affected	Main Drain (Open)	Main Drain (Closed) & 'B' Drain	Total Assessment	Less Gov't Grant	Less Allowances	Net Estimated Expense	
Van Diepenbeek Municipal Drain 2023	11,12,13	1	Peter Schlegel	1-006	38.66	\$ 1,877.00	\$ -	\$ 1,877.00	*	\$ -	\$ 1,877.00	
	12,13	1	Tyler & Rachel Kernighan	1-068	8.89	\$ 387.00	\$ -	\$ 387.00	\$ 129.00	\$ -	\$ 258.00	
	14	1	Vererna Berghe Von Trips	1-008	13.30	\$ 651.00	\$ -	\$ 651.00	*	\$ -	\$ 651.00	
	14	1	Vererna Berghe Von Trips	1-069	10.10	\$ 398.00	\$ 4,772.00	\$ 5,170.00	*	\$ -	\$ 5,170.00	
	14	1	Linda Taylor	1-070	10.10	\$ 51.00	\$ 2,207.00	\$ 2,258.00	\$ 753.00	\$ -	\$ 1,505.00	
	15,16	1	Bruce & Mary Scott	1-071	50.67	\$ 2,548.00	\$ 85,551.00	\$ 88,099.00	\$ 29,366.00	\$ 1,000.00	\$ 57,733.00	
	16,17,18	1	Adam Miltenburg	1-010	17.53	\$ 882.00	\$ -	\$ 882.00	\$ 294.00	\$ -	\$ 588.00	
	17	1	Eugene & Sheila Zsiga	1-072	1.61	\$ 120.00	\$ 2,129.00	\$ 2,249.00	*	\$ -	\$ 2,249.00	
	17,18	1	Vererna Berghe Von Trips	1-073	38.86	\$ 1,954.00	\$ 78,172.00	\$ 80,126.00	*	\$ 12,000.00	\$ 68,126.00	
	19,20	1	Vererna Berghe Von Trips	1-074	40.47	\$ 2,035.00	\$ 58,806.00	\$ 60,841.00	*	\$ 12,540.00	\$ 48,301.00	
	21	1	Vererna Berghe Von Trips	1-075	19.54	\$ 983.00	\$ 39,802.00	\$ 40,785.00	*	\$ 19,740.00	\$ 21,045.00	
	22,23,24	1	Harry Van Diepenbeek	1-076	39.30	\$ 21,523.00	\$ -	\$ 21,523.00	\$ 7,174.00	\$ 1,000.00	\$ 13,349.00	
	25,26	1	James Gibson	1-077	4.42	\$ 20,785.00	\$ -	\$ 20,785.00	\$ 6,928.00	\$ 1,000.00	\$ 12,857.00	
	Total Assessments on Lands						\$ 54,194.00	\$ 271,439.00	\$ 325,633.00	\$ 44,644.00	\$ 47,280.00	\$ 233,709.00
	Sideroad 10 South		Township of Huron Kinloss		1.84	\$ 370.00	\$ 40,796.00	\$ 41,166.00			\$ 41,166.00	
	Concession 2		Township of Huron Kinloss		2.13	\$ 536.00	\$ 14,765.00	\$ 15,301.00			\$ 15,301.00	
	Total Assessments on Roads						\$ 906.00	\$ 55,561.00	\$ 56,467.00	\$ -	\$ -	\$ 56,467.00
	Total Assessments Van Diepenbeek Municipal Drain 2023						\$ 55,100.00	\$ 327,000.00	\$ 382,100.00	\$ 44,644.00	\$ 47,280.00	\$ 290,176.00

Notes:

- 1 '*' Denotes Lands not eligible for ADIP Grants.
- 2 The Net Estimated Expense is the Total Assessment less gov't grants and allowances (if applicable).



Schedule D

Assessment for Future Maintenance

Schedule of Assessment for Future Maintenance Van Diepenbeek Municipal Drain 2023

Main Drain (Open) 0+408 Culvert	Property Details					Total Maintenance Assessment	
	Part Lot	Concession	Landowner	Roll Number	Approx. Ha. Affected		
	11,12,13	1	Peter Schlegel	1-006	38.66	*	2.63%
	12,13	1	Tyler & Rachel Kernighan	1-068	8.89		0.54%
	14	1	Vererna Berghe Von Trips	1-008	13.3	*	0.91%
	14	1	Vererna Berghe Von Trips	1-069	10.1	*	0.56%
	14	1	Linda Taylor	1-070	10.1		0.07%
	15,16	1	Bruce & Mary Scott	1-071	50.67		3.56%
	16,17,18	1	Adam Miltenburg	1-010	17.53		1.23%
	17	1	Eugene & Sheila Zsiga	1-072	1.61	*	0.17%
	17,18	1	Vererna Berghe Von Trips	1-073	38.86	*	2.73%
	19,20	1	Vererna Berghe Von Trips	1-074	40.47	*	2.85%
	21	1	Vererna Berghe Von Trips	1-075	19.54	*	1.37%
	22,23,24	1	Harry Van Diepenbeek	1-076	39.3		82.12%
	Total Assessments on Lands						98.73%
	Sideroad 10 South	Township of Huron Kinloss			1.84		0.52%
	Concession 2	Township of Huron Kinloss			2.13		0.75%
	Total Assessments on Roads						1.27%
	Total Assessments						
	Main Drain (Open) 0+408 Culvert						100.00%

	Property Details					Total Maintenance Assessment		
	Part Lot	Concession	Landowner	Roll Number	Approx. Ha. Affected			
Main Drain (Open) 0+833 Culvert	11,12,13	1	Peter Schlegel	1-006	38.66	*	2.46%	
	12,13	1	Tyler & Rachel Kernighan	1-068	8.89		0.51%	
	14	1	Vererna Berghe Von Trips	1-008	13.3	*	0.85%	
	14	1	Vererna Berghe Von Trips	1-069	10.1	*	0.52%	
	14	1	Linda Taylor	1-070	10.1		0.07%	
	15,16	1	Bruce & Mary Scott	1-071	50.67		3.34%	
	16,17,18	1	Adam Miltenburg	1-010	17.53		1.16%	
	17	1	Eugene & Sheila Zsiga	1-072	1.61	*	0.16%	
	17,18	1	Vererna Berghe Von Trips	1-073	38.86	*	2.56%	
	19,20	1	Vererna Berghe Von Trips	1-074	40.47	*	2.67%	
	21	1	Vererna Berghe Von Trips	1-075	19.54	*	1.29%	
	22,23,24	1	Harry Van Diepenbeek	1-076	39.3		2.59%	
	25,26	1	James Gibson	1-077	4.42		80.63%	
	Total Assessments on Lands							98.81%
	Sideroad 10 South		Township of Huron Kinloss			1.84		0.49%
Concession 2		Township of Huron Kinloss			2.13		0.70%	
Total Assessments on Roads							1.19%	
Total Assessments								
Main Drain (Open) 0+833 Culvert							100.00%	

Main Drain (Closed) & 'B' Drain	Property Details					Total Maintenance Assessment	
	Part Lot	Concession	Landowner	Roll Number	Approx. Ha. Affected		
	14	1	Vererna Berghe Von Trips	1-069	5.28	*	2.84%
	14	1	Linda Taylor	1-070	10.1		1.31%
	15,16	1	Bruce & Mary Scott	1-071	21.86		28.42%
	17	1	Eugene & Sheila Zsiga	1-072	1.61	*	1.73%
	17,18	1	Vererna Berghe Von Trips	1-073	15.75	*	20.48%
	19,20	1	Vererna Berghe Von Trips	1-074	11.94	*	15.52%
	21	1	Vererna Berghe Von Trips	1-075	8.89	*	11.56%
	Total Assessments on Lands						81.86%
Sideroad 10 South		Township of Huron Kinloss		1		5.20%	
Concession 2		Township of Huron Kinloss		1.99		12.94%	
Total Assessments on Roads						18.14%	
Total Assessments							
Main Drain (Closed) & 'B' Drain						100.00%	

Notes:

- 1 '*' Denotes Lands not eligible for ADIP Grants.
- 2 All maintenance activities on road right-of-ways shall be completed at the expense of the road authority having jurisdiction over the road.
- 3 Lands located upstream of the maintenance shall be determined by the Drainage Superintendent.



Specifications for the Construction of Municipal Drainage Works

DIVISION A – General Conditions
DIVISION C – Specification for Tile Drains
DIVISION H – Special Provisions



DIVISION A

General Conditions



CONTENTS

A.1.	SCOPE.....	1
A.2.	TENDERS.....	1
A.3.	EXAMINATIONS OF SITE, DRAWINGS, AND SPECIFICATIONS.....	1
A.4.	PAYMENT	2
A.5.	CONTRACTOR’S LIABILITY INSURANCE	2
A.6.	LOSSES DUE TO ACTS OF NATURE, ETC.....	2
A.7.	COMMENCEMENT AND COMPLETION OF WORK.....	2
A.8.	WORKING AREA AND ACCESS.....	3
A.9.	SUB-CONTRACTORS	3
A.10.	PERMITS, NOTICES, LAWS AND RULES.....	3
A.11.	RAILWAYS, HIGHWAYS, AND UTILITIES	3
A.12.	ERRORS AND UNUSUAL CONDITIONS.....	3
A.13.	ALTERATIONS AND ADDITIONS.....	3
A.14.	SUPERVISION	4
A.15.	FIELD MEETINGS.....	4
A.16.	PERIODIC AND FINAL INSPECTIONS.....	4
A.17.	ACCEPTANCE BY THE MUNICIPALITY	4
A.18.	WARRANTY.....	4
A.19.	TERMINATION OF CONTRACT BY THE MUNICIPALITY	4
A.20.	TESTS.....	5
A.21.	POLLUTION	5
A.22.	SPECIES AND RISK.....	5
A.23.	ROAD CROSSINGS.....	5
A.23.1.	ROAD OCCUPANCY PERMIT	5
A.23.2.	ROAD CLOSURE REQUEST AND CONSTRUCTION NOTIFICATION.....	6
A.23.3.	TRAFFIC CONTROL.....	6
A.23.4.	WEATHER.....	6
A.23.5.	EQUIPMENT	6
A.24.	LANEWAYS.....	6



A.25.	FENCES	7
A.26.	LIVESTOCK	7
A.27.	STANDING CROPS.....	7
A.28.	SURPLUS GRAVEL	7
A.29.	IRON BARS	7
A.30.	RIP-RAP	7
A.31.	CLEARING, GRUBBING AND BRUSHING	8
A.32.	RESTORATION OF LAWNS	8



DIVISION A – GENERAL CONDITIONS

A.1. Scope

The work to be done under this contract consists of supplying all labour, equipment and materials to construct the drainage work as outlined in the Scope of Work, Drawings, General Conditions and other Specifications.

A.2. Tenders

Tenders are to be submitted on a lump sum basis for the complete works or a portion thereof, as instructed by the Municipality. The Scope of Work must be completed and submitted with the Form of Tender and Agreement. A certified cheque is required as Tender Security, payable to the Treasurer of the Municipality.

All certified cheques, except that of the bidder to whom the work is awarded will be returned within ten (10) days after the tender closing. The certified cheque of the bidder to whom the work is awarded will be retained as Contract Security and returned when the Municipality receives a Completion Certificate for the work.

A certified cheque is not required if the Contractor provides an alternate form of Contract Security such as a Performance Bond for 100% of the amount of the Tender or other satisfactory security, if required/permitted by the Municipality. A Performance Bond may also be required to insure maintenance of the work for a period of one (1) year after the date of the Completion Certificate.

A.3. Examinations of Site, Drawings, and Specifications

The Tenderer must examine the premises and site to compare them with the Drawings and Specifications in order to satisfy himself of the existing conditions and extent of the work to be done before submission of his Tender. No allowance shall subsequently be made on behalf of the Contractor by reason of any error on his part. Any estimates of quantities shown or indicated on the Drawings, or elsewhere are provided for the convenience of the Tenderer. Any use made of these quantities by the Tenderer in calculating his Tender shall be done at his own risk. The Tenderer for his own protection should check these quantities for accuracy.

The standard specifications (Divisions B through G) shall be considered complementary and where a project is controlled under one of the Divisions, the remaining Divisions will apply for miscellaneous works.

In case of any inconsistency or conflict between the Drawings and Specifications, the following order of precedence shall apply:

- Direction of the Engineer
- Special Provisions (Division H)
- Scope of Work
- Contract Drawings
- Standard Specifications (Divisions B through G)
- General Conditions (Division A)



A.4. Payment

Progress payments equal to 87±% of the value of work completed and materials incorporated in the work will be made to the Contractor monthly. An additional ten per cent (10±%) will be paid 45 days after the final acceptance by the Engineer, and three per cent (3±%) of the Contract price may be reserved by the Municipality as a maintenance holdback for a one (1) year period from the date of the Completion Certificate. A greater percentage of the Contract price may be reserved by the Municipality for the same one (1) year period if in the opinion of the Engineer, particular conditions of the Contract requires such greater holdback.

After the completion of the work, any part of this reserve may be used to correct defects developed within that time from faulty workmanship and materials, provided that notice shall first be given to the Contractor and that he may promptly make good such defects.

A.5. Contractor's Liability Insurance

Prior to commencement of any work, the Contractor shall file with the Municipality evidence of compliance with all Municipality insurance requirements (Liability Insurance, WSIB, etc.) for no less than the minimum amounts as stated in the Purchasing Procedures of the Municipality. All insurance coverage shall remain in force for the entire contract period including the warranty period which expires one year after the date of the Completion Certificate.

The following are to be named as co-insured:

- Successful Contractor
- Sub-Contractor
- Municipality
- Headway Engineering

A.6. Losses Due to Acts of Nature, Etc.

All damage, loss, expense and delay incurred or experienced by the Contractor in the performance of the work, by reason of unanticipated difficulties, bad weather, strikes, acts of nature, or other mischances shall be borne by the Contractor and shall not be the subject of a claim for additional compensation.

A.7. Commencement and Completion of Work

The work must commence as specified in the Form of Tender and Agreement. If conditions are unsuitable due to poor weather, the Contractor may be required, at the discretion of the Engineer to postpone or halt work until conditions become acceptable and shall not be subject of a claim for additional compensation.

The Contractor shall give the Engineer a minimum of 48 hours notice before commencement of work. The Contractor shall then arrange a meeting to be held on the site with Contractor, Engineer, and affected Landowners to review in detail the construction scheduling and other details of the work.

If the Contractor leaves the job site for a period of time after initiation of work, he shall give the Engineer and the Municipality a minimum of 24 hours notice prior to returning to the project. If any work is commenced without notice to the Engineer, the Contractor shall be fully responsible for all such work undertaken prior to such notification.



The work must proceed in such a manner as to ensure its completion at the earliest possible date and within the time limit set out in the Form of Tender and Agreement.

A.8. Working Area and Access

Where any part of the drain is on a road allowance, the road allowance shall be the working area. For all other areas, the working area available to the Contractor to construct the drain is specified in the Special Provisions (Division H).

Should the specified widths become inadequate due to unusual conditions, the Contractor shall notify the Engineer immediately. Where the Contractor exceeds the specified working widths without authorization, he shall be held responsible for the costs of all additional damages.

If access off an adjacent road allowance is not possible, each Landowner on whose property the drainage works is to be constructed, shall designate access to and from the working area. The Contractor shall not enter any other lands without permission of the Landowner and he shall compensate the Landowner for damage caused by such entry.

A.9. Sub-Contractors

The Contractor shall not sublet the whole or part of this Contract without the approval of the Engineer.

A.10. Permits, Notices, Laws and Rules

The Contractor shall obtain and pay for all necessary permits or licenses required for the execution of the work (but this shall not include MTO encroachment permits, County Road permits permanent easement or rights of servitude). The Contractor shall give all necessary notices and pay for all fees required by law and comply with all laws, ordinances, rules and regulations relating to the work and to the preservation of the public's health and safety.

A.11. Railways, Highways, and Utilities

A minimum of 72 hours' notice to the Railway or Highways, exclusive of Saturdays, Sundays, and Statutory Holidays, is required by the Contractor prior to any work activities on or affecting the applicable property. In the case of affected Utilities, a minimum of 48 hours' notice to the utility owner is required.

A.12. Errors and Unusual Conditions

The Contractor shall notify the Engineer immediately of any error or unusual conditions which may be found. Any attempt by the Contractor to correct the error on his own shall be done at his own risk. Any additional cost incurred by the Contractor to remedy the wrong decision on his part shall be borne by the Contractor. The Engineer shall make the alterations necessary to correct errors or to adjust for unusual conditions during which time it will be the Contractor's responsibility to keep his men and equipment gainfully employed elsewhere on the project.

The Contract amount shall be adjusted in accordance with a fair evaluation of the work added or deleted.

A.13. Alterations and Additions

The Engineer shall have the power to make alterations in the work shown or described in the Drawings and Specifications and the Contractor shall proceed to make such changes without causing delay. In



every such case, the price agreed to be paid for the work under the Contract shall be increased or decreased as the case may require according to a fair and reasonable evaluation of the work added or deleted. The valuation shall be determined as a result of negotiations between the Contractor and the Engineer, but in all cases the Engineer shall maintain the final responsibility for the decision. Such alterations and variations shall in no way render the Contract void. No claims for a variation or alteration in the increased or decreased price shall be valid unless done in pursuance of an order from the Engineer and notice of such claims made in writing before commencement of such work. In no such case shall the Contractor commence work which he considers to be extra before receiving the Engineer's approval.

A.14. Supervision

The Contractor shall give the work his constant supervision and shall keep a competent foreman in charge at the site.

A.15. Field Meetings

At the discretion of the Engineer, a field meeting with the Contractor or his representative, the Engineer and with those others that the Engineer deems to be affected, shall be held at the location and time specified by the Engineer.

A.16. Periodic and Final Inspections

Periodic inspections by the Engineer will be made during the performance of the work. If ordered by the Engineer, the Contractor shall expose the drain as needed to facilitate inspection by the Engineer.

Final inspection by the Engineer will be made within twenty (20) days after he has received notice from the Contractor that the work is complete.

A.17. Acceptance By the Municipality

Before any work shall be accepted by the Municipality, the Contractor shall correct all deficiencies identified by the Engineer and the Contractor shall leave the site neat and presentable.

A.18. Warranty

The Contractor shall repair and make good any damages or faults in the drain that may appear within one (1) year after its completion (as dated on the Completion Certificate) as the result of the imperfect or defective work done or materials furnished if certified by the Engineer as being due to one or both of these causes; but nothing herein contained shall be construed as in any way restricting or limiting the liability of the Contractor under the laws of the Country, Province or Locality in which the work is being done. Neither the Completion Certificate nor any payment there under, nor any provision in the Contract Documents shall relieve the Contractor from his responsibility.

A.19. Termination of Contract By The Municipality

If the Contractor should be adjudged bankrupt, or if he should make a general assignment for the benefit of his creditors, or if a receiver should be appointed on account of his insolvency, or if he should refuse or fail to supply enough properly skilled workmen or proper materials after having received seven (7) days notice in writing from the Engineer to supply additional workmen or materials to commence or complete the works, or if he should fail to make prompt payment to Sub-Contractors, or for material, or labour, or persistently disregards laws, ordinances, or the instruction of the Engineer,



or otherwise be guilty of a substantial violation of the provisions of the Contract, then the Municipality, upon the certificate of the Engineer that sufficient cause exists to justify such action, may without prejudice to any other right or remedy, by giving the Contractor written notice, terminate the employment of the Contractor and take possession of the premises, and of all materials, tools and appliances thereon, and may finish the work by whatever method the Engineer may deem expedient but without delay or expense. In such a case, the Contractor shall not be entitled to receive any further payment until the work is finished. If the unpaid balance of the Contract price will exceed the expense of finishing the work including compensation to the Engineer for his additional services and including the other damages of every name and nature, such excess shall be paid by the Contractor. If such expense will exceed such unpaid balance, the Contractor shall pay the difference to the Municipality. The expense incurred by the Municipality, as herein provided, shall be certified by the Engineer.

If the Contract is terminated by the Municipality due to the Contractor's failure to properly commence the works, the Contractor shall forfeit the certified cheque bid deposit and furthermore shall pay to the Municipality an amount to cover the increased costs, if any, associated with a new Tender for the Contract being terminated.

If any unpaid balance and the certified cheque do not match the monies owed by the Contractor upon termination of the Contract, the Municipality may also charge such expense against any money which may thereafter be due to the Contractor from the Municipality.

A.20. Tests

The cost for the testing of materials supplied to the job by the Contractor shall be borne by the Contractor. The Engineer reserves the right to subject any lengths of any tile or pipe to a competent testing laboratory to ensure the adequacy of the tile or pipe. If any tile supplied by the Contractor is determined to be inadequate to meet the applicable A.S.T.M. standards, the Contractor shall bear full responsibility to remove and/or replace all such inadequate tile in the Contract with tile capable of meeting the A.S.T.M. Standards.

A.21. Pollution

The Contractor shall keep their equipment in good repair. The Contractor shall refuel or repair equipment away from open water.

If polluted material from construction materials or equipment is caused to flow into the drain, the Contractor shall immediately notify the Ministry of the Environment, and proceed with the Ministry's protocols in place to address the situation.

A.22. Species and Risk

If a Contractor encounters a known Species at Risk as designated by the MNR or DFO, the Contractor shall notify the Engineer immediately and follow the Ministry's guidelines to deal with the species.

A.23. Road Crossings

This specification applies to all road crossings (Municipality, County, Regional, or Highway) where no specific detail is provided on the drawings or in the standard specifications. This specification in no way limits the Road Authority's regulations governing the construction of drains on their Road Allowance.

A.23.1. Road Occupancy Permit



Where applicable, the Contractor must submit an application for a road occupancy permit to the Road Authority and allow a minimum of five (5) working days for its review and issuance.

A.23.2. Road Closure Request and Construction Notification

The Contractor shall submit written notification of construction and request for road closure (if applicable) to the Road Authority and the Engineer for review and approval a minimum of five (5) working days prior to proceeding with any work on the road allowance. The Contractor shall be responsible for notifying all applicable emergency services, schools, etc. of the road closure or construction taking place.

A.23.3. Traffic Control

The Contractor shall supply flagmen, and warning signs and ensure that detour routes are adequately signed in accordance with no less than the minimum standards as set out in the Ontario Traffic Manual's Book 7.

A.23.4. Weather

No construction shall take place during inclement weather or periods of poor visibility.

A.23.5. Equipment

No construction material and/or equipment is to be left within three (3) metres of the travelled portion of the road overnight or during periods of inclement weather.

If not stated on the drawings, the road crossing shall be constructed by open cut method. Backfill from the top of the cover material over the subsurface pipe or culvert to the under side of the road base shall be Granular "B". The backfill shall be placed in lifts not exceeding 300mm in thickness and each lift shall be thoroughly compacted to 98% Standard Proctor. Granular "B" road base for County Roads and Highways shall be placed to a 450mm thickness and Granular "A" shall be placed to a thickness of 200mm. Granular road base materials shall be thoroughly compacted to 100% Standard Proctor.

Where the road surface is paved, the Contractor shall be responsible for placing HL-8 Hot Mix Asphalt patch at a thickness of 50mm or of the same thickness as the existing pavement structure. The asphalt patch shall be flush with the existing roadway on each side and without overlap.

Excavated material from the trench beyond 1.25 metres from the travelled portion or beyond the outside edge of the gravel shoulder may be used as backfill in the trench in the case of covered drains. The material shall be compacted in lifts not exceeding 300mm.

A.24. Laneways

All pipes crossing laneways shall be backfilled with material that is clean, free of foreign material or frozen particles and readily tamped or compacted in place unless otherwise specified. Laneway culverts on open ditch projects shall be backfilled with material that is not easily erodible. All backfill material shall be thoroughly compacted as directed by the Engineer.

Culverts shall be bedded with a minimum of 300mm of granular material. Granular material shall be placed simultaneously on each side of the culvert in lifts not exceeding 150mm in thickness and compacted to 95% Standard Proctor Density. Culverts shall be installed a minimum of 10% of the



culvert diameter below design grade with a minimum of 450mm of cover over the pipe unless otherwise noted on the Drawings.

The backfill over culverts and subsurface pipes at all existing laneways that have granular surfaces on open ditch and closed drainage projects shall be surfaced with a minimum of 300mm of Granular “B” material and 150mm of Granular “A” material. All backfill shall be thoroughly compacted as directed by the Engineer. All granular material shall be placed to the full width of the travelled portion.

Any settling of backfilled material shall be repaired by or at the expense of the Contractor during the warranty period of the project and as soon as required.

A.25. Fences

No earth is to be placed against fences and all fences removed by the Contractor shall be replaced by him in as good a condition as found. Where practical the Contractor shall take down existing fences in good condition at the nearest anchor post and roll it back rather than cutting the fence and attempting to patch it. The replacement of the fences shall be done to the satisfaction of the Engineer. Any fences found in such poor condition where the fence is not salvageable, shall be noted and verified with the Engineer prior to commencement of work.

Fences damaged beyond repair by the Contractor’s negligence shall be replaced with new materials, similar to those materials of the existing fence, at the Contractor’s expense. The replacement of the fences shall be done to the satisfaction of the Landowner and the Engineer.

Any fences paralleling an open ditch that are not line fences that hinder the proper working of the excavating machinery, shall be removed and rebuilt by the Landowner at his own expense.

The Contractor shall not leave fences open when he is not at work in the immediate vicinity.

A.26. Livestock

The Contractor shall provide each landowner with 48 hours notice prior to removing any fences along fields which could possibly contain livestock. Thereafter, the Landowner shall be responsible to keep all livestock clear of the construction areas until further notified. The Contractor shall be held responsible for loss or injury to livestock or damage caused by livestock where the Contractor failed to notify the Landowner, or through negligence or carelessness on the part of the Contractor.

A.27. Standing Crops

The Contractor shall be responsible for damages to standing crops which are ready to be harvested or salvaged along the course of the drain and access routes if the Contractor has failed to notify the Landowners 48 hours prior to commencement of the work on that portion of the drain.

A.28. Surplus Gravel

If as a result of any work, gravel or crushed stone is required and not all the gravel or crushed stone is used, the Contractor shall haul away such surplus material.

A.29. Iron Bars

The Contractor is responsible for the cost of an Ontario Land Surveyor to replace any iron bars that are altered or destroyed during the course of the construction.

A.30. Rip-Rap



Rip-rap shall be quarry stone rip-rap material and shall be the sizes specified in the Special Provisions. Broken concrete shall not be used as rip-rap unless otherwise specified.

A.31. Clearing, Grubbing and Brushing

This specification applies to all brushing where no specific detail is provided on the drawings or in the Special Provisions.

The Contractor shall clear, brush and stump trees from within the working area that interfere with the installation of the drainage system.

All trees, limbs and brush less than 150mm in diameter shall be mulched. Trees greater than 150mm in diameter shall be cut and neatly stacked in piles designated by the Landowners.

A.32. Restoration of Lawns

This specification applies to all lawn restoration where no specific detail is provided on the drawings or in the Special Provisions and no allowance for damages has been provided under Section 30 of the Drainage Act RSO 1990 to the affected property.

The Contractor shall supply “high quality grass seed” and the seed shall be broadcast by means of an approved mechanical spreader. All areas on which seed is to be placed shall be loose at the time of broadcast to a depth of 25mm. Seed and fertilizer shall be spread in accordance with the supplier’s recommendations unless otherwise directed by the Engineer. Thereafter it will be the responsibility of the Landowner to maintain the area in a manner so as to promote growth

END OF DIVISION



DIVISION C

Specifications for Tile Drains



CONTENTS

C.1.	PIPE MATERIALS	1
C.2.	ALIGNMENT	1
C.3.	PROFILE	1
C.4.	EXCAVATION	2
C.5.	INSTALLATION	2
C.6.	TRENCH CROSSINGS	3
C.7.	OUTLET PROTECTION	3
C.8.	CATCH BASINS AND JUNCTION BOXES	3
C.9.	TRIBUTARY DRAINS.....	4
C.10.	CLEARING, GRUBBING AND MULCHING	5
C.11.	ROADS AND LANEWAY SUB-SURFACE CROSSINGS	5
C.12.	FILLING IN EXISTING DITCHES.....	5
C.13.	CONSTRUCTION OF GRASSED WATERWAYS	5
C.14.	UNSTABLE SOIL	5
C.15.	ROCKS.....	5
C.16.	BROKEN OR DAMAGED TILE	6
C.17.	RECOMMENDED PRACTICE FOR CONSTRUCTION OF SUB-SURFACE DRAINAGE SYSTEMS.....	6



DIVISION C – SPECIFICATIONS FOR TILE DRAINS

C.1. Pipe Materials

Concrete Tile

Concrete drain tile shall conform to the requirements of the most recent A.S.T.M. specification for Heavy-Duty Extra Quality drain tile. All tile with diameters less than 600mm shall have a pipe strength of 1500D. All tile with diameters 600mm or larger shall have a pipe strength of 2000D.

All tile furnished shall be subject to the approval of the Engineer. All rejected tile are to be immediately removed from the site.

High Density Polyethylene (HDPE) Pipe

All HDPE pipe shall be dual-wall corrugated drainage pipe with a smooth inner wall. HDPE pipe shall have a minimum stiffness of 320 kPa at 5% deflection.

Unless otherwise noted, all sealed HDPE pipe shall have a water tight gasketed bell and spigot joining system meeting the minimum requirements of CSA B182.8. Perforated HDPE pipe shall have a soil tight joining system, and shall be enveloped in non-woven geotextile filter sock.

C.2. Alignment

The Contractor shall contact the Engineer to establish the course of the drain. Where an existing drain is to be removed and replaced by the new drain, or where the new drain is to be installed parallel to an existing drain, the Contractor shall locate the existing drain (including repairing damaged tile caused by locating) at intervals along the course of the drain. The costs of locating shall be included in the tender price.

The drain shall run in as straight a line as possible throughout its length, except that at intersections of other watercourses or at sharp corners, it shall run on a curve of at least 15 metres radius. The new tile drain shall be constructed at an offset from and parallel with any ditch or defined watercourse in order that fresh backfill in the trench will not be eroded by the flow of surface water.

The Contractor shall exercise care not to disturb any existing tile drain or drains which parallel the course of the new drain, particularly where the new and existing tile act together to provide the necessary capacity. Where any such existing drain is disturbed or damaged, the Contractor shall perform the necessary repair at his expense.

C.3. Profile

Benchmarks have been established along the course of the drain which are to govern the elevations of the drain. The location and elevations of the benchmarks are shown on the drawings. Tile is to be installed to the elevation and grade shown on the profiles. Accurate grade control must be maintained by the Contractor at all times.

When installing a drain towards a fixed point such as a bore pipe, the Contractor shall uncover the pipe and confirm the elevation a sufficient distance away from the pipe in order to allow for any necessary minor grade adjustments to be made.



C.4. Excavation

Wheel machine

Unless otherwise specified, all trenching shall be carried out with a wheel machine approved by the Engineer. The wheel machine shall shape the bottom of the trench to conform to the outside diameter of the pipe. The minimum trench width shall be equal to the outside diameter of the pipe plus 100mm on each side of the pipe, unless otherwise specified. The maximum trench width shall be equal to the outside diameter of the pipe plus 300mm on each side of the pipe, unless otherwise specified.

Scalping

Where the depths of cuts in isolated areas along the course of the drain as shown on the profile exceed the capability of the Contractor's wheel machine, he shall lower the surface grade in order that the wheel machine may trench to the correct depth. Topsoil is to be stripped over a sufficient width that no subsoil will be deposited on top of the topsoil. Subsoil will then be removed to the required depth and piled separately. Upon completion, the topsoil will then be replaced to an even depth over the disturbed area. The cost for this work shall be included in his tender price.

Excavator

Where the use of an excavator is used in-lieu of a wheel machine, the topsoil shall be stripped and replaced in accordance with Item C.4.2. All tile shall be installed on 19mm clear crushed stone bedding placed to a minimum depth of 150mm which has been shaped to conform to the bottom of the pipe. The Contractor shall include the costs of this work in his tender price.

C.5. Installation

Concrete Tile

The tile is to be laid with close joints and in regular grade and alignment in accordance with the drawings. The tiles are to be bevelled, if necessary to ensure close joints. The inside of the tile is to be kept clear when laid. The sides of the tile are to be supported by partial filling of the trench (blinding) prior to inspection by the Engineer. No tile shall be backfilled until inspected by the Engineer unless otherwise permitted by the Engineer. The tile shall be backfilled such that a sufficient mound of backfill is placed over the trench to ensure that no depression remains after settling occurs in the backfill.

Where a tile connects to a catch basin or similar structure, the Contractor shall include in his tender price for the supply and placement of compacted Granular 'A' bedding or 19mm clear crushed stone under areas backfilled from the underside of the pipe to undisturbed soil. Where a tile drain passes through a bore pit, the Contractor shall include in his tender price for the supply and placement of compacted Granular 'A' bedding or 19mm clear crushed stone from the underside of the pipe down to undisturbed soil with the limits of the bore pit.

The Contractor shall supply and wrap all concrete tile joints with Mirafi 160N geotextile filter material as part of this contract. The width of the filter material should be:

- 300mm wide for tile sizes 150mm diameter to 350mm diameter.
- 400mm wide for tile sizes 400mm diameter to 750mm diameter.
- 500mm wide for tile sizes larger than 750mm diameter.

The filter material shall completely cover the tile joint and shall have a minimum overlap of 300mm. The type of filter material shall be.



HDPE Pipe

HDPE pipe shall be installed using compacted Granular 'A' bedding or 19mm clear crushed stone bedding from 150mm below the pipe to 300mm above the pipe. All granular material shall be compacted using a suitable mechanical vibratory compactor. Granular bedding and backfill shall be placed in lifts not exceeding 300mm and compacted to at least 95% Standard Proctor Maximum Dry Density (SPMDD).

Where a pipe connects to a catch basin or similar structure, the Contractor shall include in his tender price for the supply and placement of compacted Granular 'A' bedding or 19mm clear crushed stone under areas backfilled from the underside of the pipe to undisturbed soil. Where a pipe passes through a bore pit, the Contractor shall include in his tender price for the supply and placement of compacted Granular 'A' bedding or 19mm clear crushed stone from the underside of the pipe down to undisturbed soil with the limits of the bore pit.

As determined by the Engineer, unsuitable backfill material must be hauled off-site by the Contractor and Granular "B" shall be used as replacement backfill material.

C.6. Trench Crossings

The Contractor shall not cross the backfilled trench with any construction equipment or vehicles, except by one designated crossing location on each property. The Contractor shall ensure that the bedding and backfill material at this designated crossing location is properly placed and compacted so as to adequately support the equipment and vehicles that may cross the trench. The Contractor may undertake any other approved work to ensure the integrity of the tile at the crossing location. The Contractor shall ensure that no equipment or vehicles travel along the length of the trench. The Contractor shall be responsible for any damage to the new tile caused by the construction of the drain.

C.7. Outlet Protection

A tile drain outlet into a ditch shall be either HDPE pipe or corrugated steel pipe and shall include a hinged grate for rodent protection. The maximum spacing between bars on the rodent grate shall be 40mm. All corrugated steel outlet pipes shall be bevelled at the end to generally conform to the slope of the ditch bank.

Quarry stone rock rip-rap protection and geotextile filter material (Mirafi 160N), shall be installed around the outlet pipe and extended downstream a minimum distance of three metres, unless otherwise specified. The protection shall extend to the top of the backfilled trench and below the pipe to 300 mm under the streambed. The protection shall also extend 600mm into undisturbed soil on either side of the backfilled trench. In some locations, rip-rap may be required on the bank opposite the outlet.

Where the outlet occurs at the upper end of an open ditch, the rip-rap protection will extend all around the end of the ditch and to a point 800mm downstream on either side. Where heavy overflow is likely to occur, sufficient additional rip-rap and filter material shall be placed as directed by the Engineer to prevent the water cutting around the protection.

C.8. Catch Basins and Junction Boxes

Unless otherwise noted, catch basins shall be in accordance with OPSD 705.010 and 705.030. The catch basin grate shall be a "Birdcage" type substantial steel grate, removable for cleaning and shall be inset into a recess provided around the top of the structure. The grate shall be fastened to the catch basin with bolts into the concrete. Spacing of bars on grates for use on 600mmX600mm



structures shall be 65mm centre to centre. Spacing of bars on grates for use on structures larger than 600mmX600mm shall be 90mm.

All catch basins shall be backfilled with compacted Granular 'A' or 19mm clear crushed stone placed to a minimum width of 300mm on all sides. If settling occurs after construction, the Contractor shall supply and place sufficient granular material to maintain the backfill level flush with adjacent ground. The riser sections of the catch basin shall be wrapped with filter cloth.

Quarry stone rip-rap protection shall be placed around all catch basins and shall extend a minimum distance of one (1) metre away from the outer edge of each side of the catch basin, and shall be placed so that the finished surface of the rip-rap is flush with the existing ground.

If there are no existing drains to be connected to the catch basin at the top end of the drain, a plugged tile shall be placed in the upstream wall with the same elevations as the outlet tile.

Junction boxes shall have a minimum cover over the lid of 450mm.

The Contractor shall include in his tender price for the construction of a berm behind all ditch inlet structures. The berm shall be constructed of compacted clay keyed 300mm into undisturbed soil. The top of the spill way of the earth berm shall be the same elevation as the high wall of the ditch inlet catch basin. The earth berm shall be covered with 100mm depth of topsoil and seeded with an approved green seed mixture. The Contractor shall also include for regrading, shaping and seeding of road ditches for a maximum of 15 metres each way from all catch basins.

The Contractor shall clean all catch basin sumps after completion of the drain installation. Catch basin markers shall be placed beside each catch basin.

C.9. Tributary Drains

Any tributary tile encountered in the course of the drain is to be carefully taken up by the Contractor and placed clear of the excavated earth. If the tributary drains encountered are clean or reasonably clean, they shall be connected into the new drain in accordance with the typical tile drain connection detail. Tributary tile drain connections into the new drain shall be made using high density polyethylene agricultural drain tubing installed on and backfilled with 19mm clear crushed stone. All tile drain connections into the new drain shall be either a cored hole with an insert coupler or a manufactured tee.

Where the existing drains are full of sediment, the decision to connect the tributary drain to the new drain shall be left to the Engineer. The Contractor shall be paid for each tributary drain connection as outlined in the Form of Tender and Agreement.

The Contractor shall be responsible for all tributary tile connections for a period of one year from the date of the Completion Certificate. After construction, any missed tile connections required to be made into the new drain shall be paid at the same rate as defined in the Form of Tender and Agreement. The Contractor will have the option to make any subsequent tile connections or have the Municipality make the required connections and have the cost of which deducted from the holdback.

Where an open ditch is being replaced by a new tile drain, existing tile outlets entering the ditch from the side opposite the new drain shall be extended to the new drain.

Where the Contractor is required to connect an existing tile which is not encountered in the course of the drain, the cost of such work shall constitute an extra to the contract.



C.10. Clearing, Grubbing and Mulching

The Contractor shall clear, brush and stump trees from within the working area.

All trees or limbs 150mm or larger, that is necessary to remove, shall be cut, trimmed and neatly stacked in the working width for the use or disposal by the Landowner. Brush and limbs less than 150mm in diameter shall be mulched.

Clearing, grubbing and mulching shall be carried out as a separate operation from installing the drain, and shall not be completed simultaneously at the same location.

C.11. Roads and Laneway Sub-Surface Crossings

All roads and laneway crossings may be made with an open cut. The Contractor may use original ground as backfill to within 600mm of finished grade only if adequate compaction and if the use of the original ground backfill has been approved beforehand by the Engineer.

C.12. Filling In Existing Ditches

The Contractor shall backfill the ditch sufficiently for traversing by farm equipment. If sufficient material is available on-site to fill in the existing ditch, the topsoil shall be stripped and the subsoil shall be bulldozed into the ditch and the topsoil shall then be spread over the backfilled waterway. The Contractor shall ensure sufficient compaction of the backfill and if required, repair excess settlement up to the end of the warranty period.

C.13. Construction of Grassed Waterways

Where the Contractor is required to construct a grassed waterway, the existing waterway shall be filled in, regraded, shaped and a seed bed prepared prior to applying the grass seed. The grass seed shall be fresh, clean and new crop seed, meeting the requirements of the MTO.

- 55% Creeping Red Fescue
- 15% Perennial Rye Grass
- 27% Kentucky Bluegrass
- 3% White Clover

Grass seed shall be applied at the rate of 100 kg/ha.

C.14. Unstable Soil

The Contractor shall immediately contact the Engineer if unstable soil is encountered. The Engineer shall, after consultation with the Contractor, determine the action necessary and a price for additions or deletions shall be agreed upon prior to further drain installation.

C.15. Rocks

The Contractor shall immediately contact the Engineer if boulders of sufficient size and number are encountered such that the Contractor cannot continue trenching with a wheel machine. The Engineer shall determine the action necessary and a price for additions or deletions shall be agreed upon prior to further drain installation.



If only scattered large stone or boulders are removed on any project, the Contractor shall either excavate a hole to bury same adjacent to the drain, or he shall haul the stones or boulders to a location designated by the Landowner.

C.16. Broken or Damaged Tile

The Contractor shall remove and dispose of all broken (existing or new), damaged or excess tile off site.

C.17. Recommended Practice For Construction of Sub-Surface Drainage Systems

Drainage Guide for Ontario, Ministry of Agriculture, Food and Rural Affairs, Publication 29 and its amendments, dealing with the construction of Subsurface Drainage Systems, shall be the guide to all methods and materials to be used in the construction of tile drains except where superseded by other Specifications of the Contract.

END OF DIVISION



SPECIAL PROVISIONS

Van Diepenbeek Municipal Drain 2023



CONTENTS

1.0	GENERAL	1
2.0	UTILITIES	1
3.0	WORKING AREA AND ACCESS	1
4.0	ENDANGERED SPECIES ACT AND THE EASTERN MEADOWLARK	1
5.0	CLEARING BRUSHING AND MULCHING	2
6.0	CULVERT INSTALLATIONS	2
7.0	PIPE AND INSTALLATION	2
8.0	TOPSOIL STRIPPING AND FINE GRADING	4
9.0	OUTLET STRUCTURE	4
10.0	SEEDING	4
11.0	EXISTING DRAINS/TILE CONNECTIONS	4
12.0	CATCHBASINS AND JUNCTION BOXES	4
13.0	ROAD WORKS/CROSSING	5
14.0	RIP-RAP	6
15.0	EROSION AND SEDIMENT CONTROL	6

Special Provisions means special directions containing requirements particular to the work not adequately provided for by the standard or supplemental specifications. Special provisions shall take precedence and govern over any standard or supplemental specification.

1.0 GENERAL

The Contractor shall notify the Landowner, the Drainage Superintendent, and the Engineer 48 hours prior to construction.

The Contractor shall arrange a pre-construction meeting and shall invite the Landowners on whose property work will take place, and the Engineer, and the Drainage Superintendent.

The Contractor shall verify the location of the new drainage system with the Engineer and Landowner prior to construction.

The Contractor shall check and verify all dimensions and elevations and report any discrepancies to the Engineer prior to proceeding with the work.

The Contractor must maintain access to all driveways along the route of the drain as well as always maintain access for all emergency vehicles during the construction.

The Contractor shall be responsible for settlement within the warranty period.

2.0 UTILITIES

All utilities shall be located and uncovered in the affected areas by the Contractor prior to construction.

The locations and elevations of all utilities shown on the drawings are approximate locations. Actual locations and elevations of all utilities must be verified by the Contractor prior to construction.

The Contractor shall arrange to have a representative of the utility owner on site during construction if it is a requirement by the utility owner.

3.0 WORKING AREA AND ACCESS

The average working width for construction purposes shall be 25 metres along the alignment of the proposed drain.

Access to the working area shall be designated by the Landowner.

4.0 ENDANGERED SPECIES ACT AND THE EASTERN MEADOWLARK

The Contractor shall review species information made available by the Ministry of Environment, Conservation & Parks (MECP) prior to the start of construction to identify the species should any be observed on site.

The Contractor shall designate a staff member to inspect the daily working area for the species, and their nests prior to the start of any work activities each day. The Contractor shall complete the following daily log of inspections.



Eastern Meadowlark – Daily Inspection Log				
Date	Daily Work Area (Sta. x+xxx to Sta. y+yyy)	Number of Sightings	Comments	Staff Signature

Should an Eastern Meadowlark or its nest be encountered, the Contractor shall immediately flag the location, obtain GPS coordinates of nesting site flags, and notify the Contract Administrator, and the Site Foreman. The Contractor shall ensure that construction activities are modified to not cause harm to the species, or its nest. The Contract Administrator shall notify the MECPC.

5.0 CLEARING BRUSHING AND MULCHING

The Contractor shall clear, brush and mulch trees from within the working area that interfere with the construction of the drainage system. The Contractor shall not clear all trees within the working area unless the full working width in a specific section is required for the installation of the drain and unless the Engineer has authorized the full clearing of the trees.

All trees, limbs, and brush less than 150mm in diameter shall be mulched/chipped. Clearing and brushing shall be done prior to the construction of the drain. Trees and branches greater than 150mm in diameter shall be cut into lengths no greater than four metres and placed in nearby stacks designated by the Landowner. Trees removed from road right-of-ways shall be mulched or disposed of offsite by the Contractor.

6.0 CULVERT INSTALLATIONS

6.1 Existing Culvert Removals

The existing crossings at Sta. 0+408 and Sta. 0+833 shall be removed and disposed of offsite by the Contractor.

6.2 New Crossings

Construction of the crossings shall occur during low flow or no flow conditions. If construction is not possible during low flow conditions, the Contractor shall implement a flow diversion scheme.

The crossing shall be installed in accordance with the attached culvert installation details and the manufacturer’s specifications.

All stone rip-rap material shall be quarry stone 150mm to 300mm diameter and placed to a depth of 400mm. Geo-textile filter material shall be laid prior to the placement of stone rip-rap.

7.0 PIPE AND INSTALLATION

7.1 Concrete Field Tile

An approved wheel trencher shall be used to install the concrete field tile whenever possible.



All concrete tile shall be Heavy-Duty Extra Quality Concrete Drain Tile 2000D.

Where the drain is to be installed by means of an approved wheel trencher, the Contractor shall strip the topsoil for the specified width centred on the proposed drain. Where the drain is to be installed by means of an approved hydraulic excavator (due to poor soil conditions), the Contractor shall strip the topsoil for a width equal to the top width of the trench, or the specified width, whichever is greater. The Contractor shall stockpile the topsoil and later spread it over the backfilled trench. The Contractor shall ensure that the topsoiled trench is left in a condition such that the landowner can perform final restoration using nothing more than farm equipment. The Contractor will not attempt to place frozen topsoil over the backfilled trench.

Concrete field tile installed by means of a wheel machine shall be backfilled using suitable native material. The backfill shall not be compacted but a sufficient mound shall be left over the trench by the Contractor to allow for settlement flush with adjacent lands.

Concrete field tile installed by means of an approved hydraulic excavator shall be installed using 19mm crushed stone bedding from a minimum of 150mm below the pipe to the springline of the pipe. Suitable native material shall be used as backfill from the springline to the underside of the topsoil.

The Contractor shall supply and wrap all concrete joints with geotextile filter material. The width of the filter material shall be:

- 300mm wide with 300mm overlap for tile sizes up to 350mm diameter.
- 400mm wide with 400mm overlap for tile sizes 400mm diameter and larger.

The filter material shall completely cover the tile joint.

The Contractor shall be responsible for all trench settlement within the warranty period.

7.2 High Density Polyethylene Pipe (HDPE)

All HDPE pipe shall be CSA B182.8 with gasketed watertight jointing systems.

All HDPE pipe shall be installed using 19mm crushed stone bedding (or approved equivalent) from a minimum of 150mm below the pipe to 150mm above the pipe. Suitable native material shall be used as backfill from 150mm above the pipe to the underside of the topsoil.

The Contractor shall construct clay plugs at intervals no greater than 50m.

The Contractor shall be responsible for all trench settlement within the warranty period.

7.3 Poor Soil Conditions

The Contractor shall submit a unit price for installation of the pipe per the detail on wrapped crushed stone bedding as a provisional item. The provisional amount for installation on wrapped crushed stone bedding shall include the supply and installation of all additional labour, equipment and materials required for the installation of the pipe by this method.

If poor soil conditions are encountered, the Contractor shall install the pipe in accordance with the detail for wrapped crushed stone bedding and shall be entitled to the provisional tender amount, in addition to the tendered standard installation price. The Contractor shall be paid for the actual lengths installed in this condition.



8.0 TOPSOIL STRIPPING AND FINE GRADING

The Contractor shall strip the topsoil along the alignment of the tile drain to a width of four metres. The Contractor shall stockpile the topsoil and later spread it over the backfilled trench. The Contractor shall ensure that the topsoiled trench is left in a condition that the Landowner can perform final restoration using nothing more than farm equipment.

9.0 OUTLET STRUCTURE

The Contractor shall place riprap in the streambed and up the side slope of the Main Drain (Open) in accordance with the typical outlet detail included in the drawing set.

10.0 SEEDING

The Contractor shall supply and spread an approved seed mixture (OPS 803 – Lowland Mix) over the disturbed areas.

All seed shall be applied using the manufacturer's application recommendations.

11.0 EXISTING DRAINS/TILE CONNECTIONS

The Contractor shall destroy the existing drain in place.

The Contractor shall make all tributary tile drain connections.

The Contractor shall be responsible for all tile connections for a period of one year after the issuance of the completion certificate. Tile connections required to be made within this warranty period shall be made at the expense of the Contractor. After construction, the Contractor will be given the option to make any subsequent tile connections or have the Municipality make said connections and have the costs of which deducted from the holdback.

The Contractor shall supply all necessary materials to complete the connections of the existing drains to the new drain. The type of materials used to make the tributary drain connections shall be verified with the engineer.

All existing drains cut off during the installation of the new drainage system that will be connected to the new drainage system shall be flagged or marked by the Contractor prior to the connection being made.

12.0 CATCHBASINS AND JUNCTION BOXES

All catch basins shall be precast concrete catch basins and shall have a 300mm sump.

All catch basin grates shall be fastened to the new catch basin and shall be hot dipped galvanized bird cage grates. Catch basin marker signs shall be erected at all catch basins.

All existing catch basins that are to be removed shall be disposed of off-site by the Contractor.

The catch basin grate elevations shall be set to the satisfaction of the Engineer. Lifts shall be placed by the Contractor on all catch basins if necessary to achieve the desired elevation when field setting the structures.

All catch basins shall be installed using 19mm crushed stone bedding from 150mm below the structure to 150mm above the top of the highest pipe entering or exiting the structure. Structures



within the road allowances shall have 300mm minimum of Granular 'B' backfill around all sides up to the underside of the topsoil layer. Structures on private property shall be backfilled using approved native material up to the underside of the topsoil layer. All backfill material shall be placed and thoroughly compacted evenly around each structure in lifts not exceeding 300mm to minimize settlement around the structures. The Contractor shall be responsible for all settlement around catch basins. Should the area around the catch basin settle after construction, the Contractor shall be responsible for providing additional rip-rap required so that the top of the rip-rap is flush with the surrounding ground.

The Contractor shall place quarry stone rip-rap material around all sides of the catch basin for a width of one metre and shall be placed on geotextile filter material.

All holes for catch basin pipe connections to be cored by the manufacturer. All pipes entering or exiting a catch basin or shall be installed such that the face of the pipe is flush with the inside wall of the structure.

The Contractor shall be responsible to repair or reapply mortar for all mortared connections into any catch basin for a period of one year after the completion certificate has been issued.

13.0 ROAD WORKS/CROSSING

13.1 Notice

The Contractor shall notify the Engineer and local road authority having jurisdiction over the road a minimum of 48 hours prior to the scheduled road crossing.

13.2 Traffic Control

The Contractor shall be responsible to arrange all traffic control signals, signs and devices that are required for safe and proper traffic management during the installation of the drainage system. The Contractor shall contact the Township of Huron-Kinloss for specific local procedures, guidelines, and timelines. Traffic control shall meet the standards of Book 7 of the Ontario Traffic Manual.

13.3 Removals

The existing subsurface pipe through Sideroad 10 South shall be removed and disposed of offsite by the Contractor.

13.4 New Installations

The Contractor shall install the new HDPE pipe in accordance with the applicable OPS specifications. All granular materials shall be placed in lifts not exceeding 300mm and compacted to at least 95% Standard Proctor Maximum Dry Density (SPMDD).

13.5 Road Restoration

The Contractor shall place 150mm of Granular 'A' and 300mm of Granular 'B' road base.

Any excavated material not suitable for the backfill of the travelled portion of the road shall be removed and disposed of offsite by the Contractor and replaced with Granular 'B'.



Any areas disturbed within the Municipal Right-of-Way shall be topsoiled and hydroseeded with an approved grass seed mixture (OPS 803 – Standard Roadside Mix).

14.0 RIP-RAP

All stone rip-rap material shall be quarry stone 150mm to 300mm diameter and placed to a depth of 300mm, unless otherwise noted. All rip-rap material shall be placed on geo-textile filter material.

15.0 EROSION AND SEDIMENT CONTROL

The Contractor shall provide adequate erosion and sediment control for the duration of construction including monitoring and maintenance of the control measures put in place. The Contractor shall inspect the erosion and sediment control measures regularly, and specifically before predicted rainfall events, and after rainfall events.



NOTES:

1. THIS MAP WAS CREATED USING COUNTY OF BRUCE GEOGRAPHIC INFORMATION SYSTEM DIGITAL DATA. THIS MAP IS A SECONDARY PRODUCT WHICH HAS NOT BEEN VERIFIED BY THE COUNTY OF BRUCE.
2. THE CONTOURS WERE CREATED USING IMAGERY DERIVED DIGITAL DATA (2015) FROM LAND INFORMATION ONTARIO.

BENCHMARK DESCRIPTIONS

BENCHMARK No. 1 ELEV.=242.74
TOP OF 450mmØ CSP OUTLET PIPE AT STA. 0+000 (MAIN DRAIN)

BENCHMARK No. 2 ELEV.=247.40
TOP DOWNSTREAM END OF 450mmØ LANEWAY CULVERT 168m NORTH OF STA. 1+100 ('B' DRAIN)

LEGEND

- LOT/CONCESSION LINE
- PROPERTY LINE
- TOWNSHIP BOUNDARY
- WETLAND LIMIT
- MAJOR WATERSHED BOUNDARY
- MINOR WATERSHED BOUNDARY
- BENCHMARK LOCATION
- B.M. 1 123.45 BENCHMARK No.
- BENCHMARK ELEVATION
- JOHN & JANE SMITH 12-345 LANDOWNER NAME(S)
- ASSESSMENT ROLL No. (ABBREVIATED)
- AREA WITHIN WATERSHED

- EXISTING FEATURES:
- DRAIN NAME** OPEN DRAIN WITH CROSSING AND FLOW DIRECTION
 - DRAIN NAME** CLOSED DRAIN WITH CATCH BASIN, MANHOLE AND FLOW DIRECTION
 - OVERLAND FLOW PATH

- PROPOSED FEATURES:
- DRAIN NAME** OPEN DRAIN WITH CROSSING AND FLOW DIRECTION
 - DRAIN NAME** CLOSED DRAIN WITH CATCH BASIN, MANHOLE AND FLOW DIRECTION



No.	REVISION	DATE (YY-MM-DD)
3	REPORT SUBMISSION	23-09-15
2	INFORMATION MEETING	23-04-27
1	ON-SITE MEETING	22-07-12



DRAWN BY: R.U.	DESIGNED BY: A.H.	CHECKED BY: S.B.
DATE: 2023-09-15	REFERENCE No. HK-004	DRAWING No. 1 OF 3

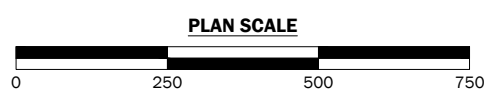
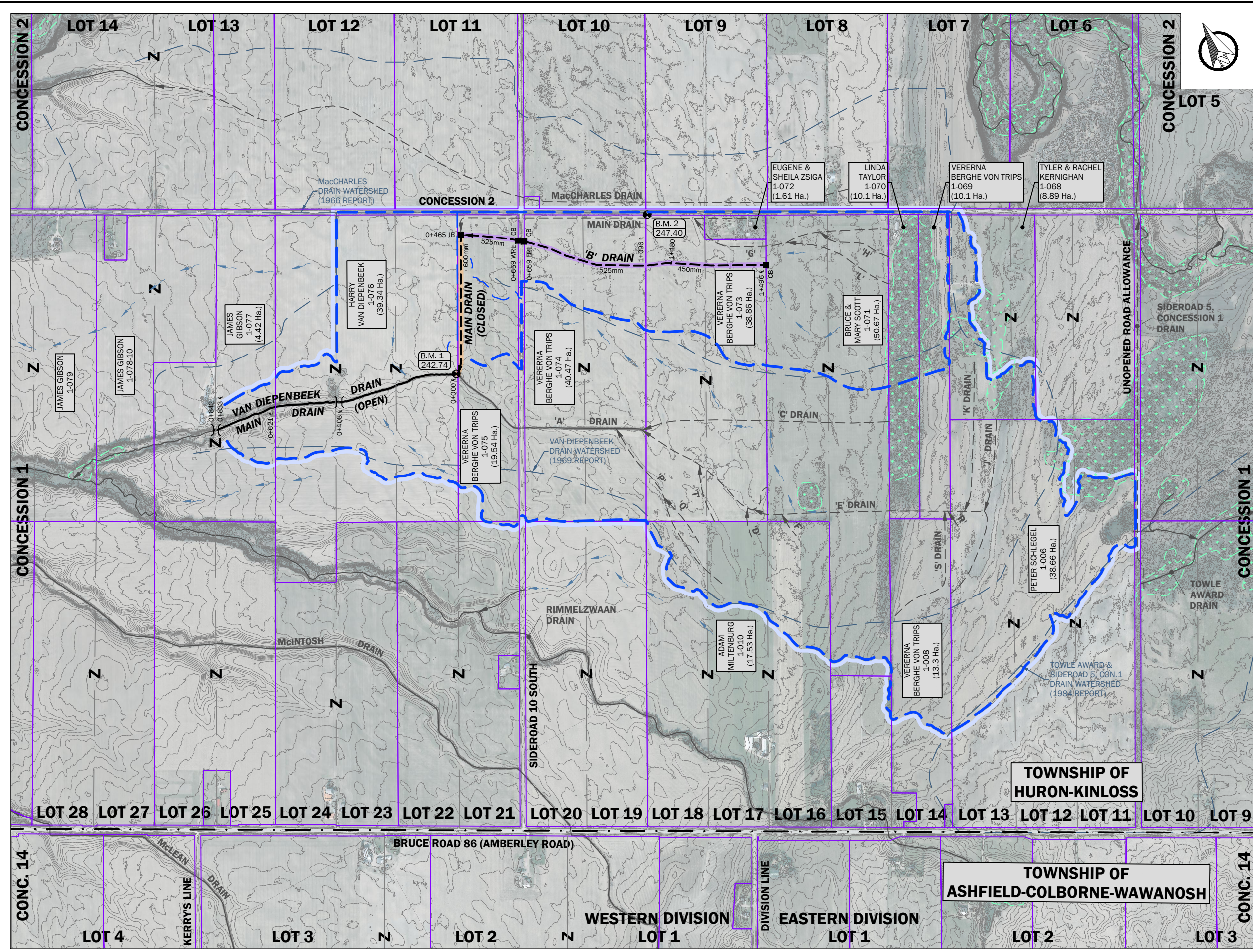



BENCHMARK DESCRIPTIONS

BENCHMARK No. 1 ELEV.=242.74
TOP OF 450mmØ CSP OUTLET PIPE AT STA. 0+000 (MAIN DRAIN)

BENCHMARK No. 2 ELEV.=247.40
TOP DOWNSTREAM END OF 450mmØ LANEWAY CULVERT 168m
NORTH OF STA. 1+100 ('B' DRAIN)

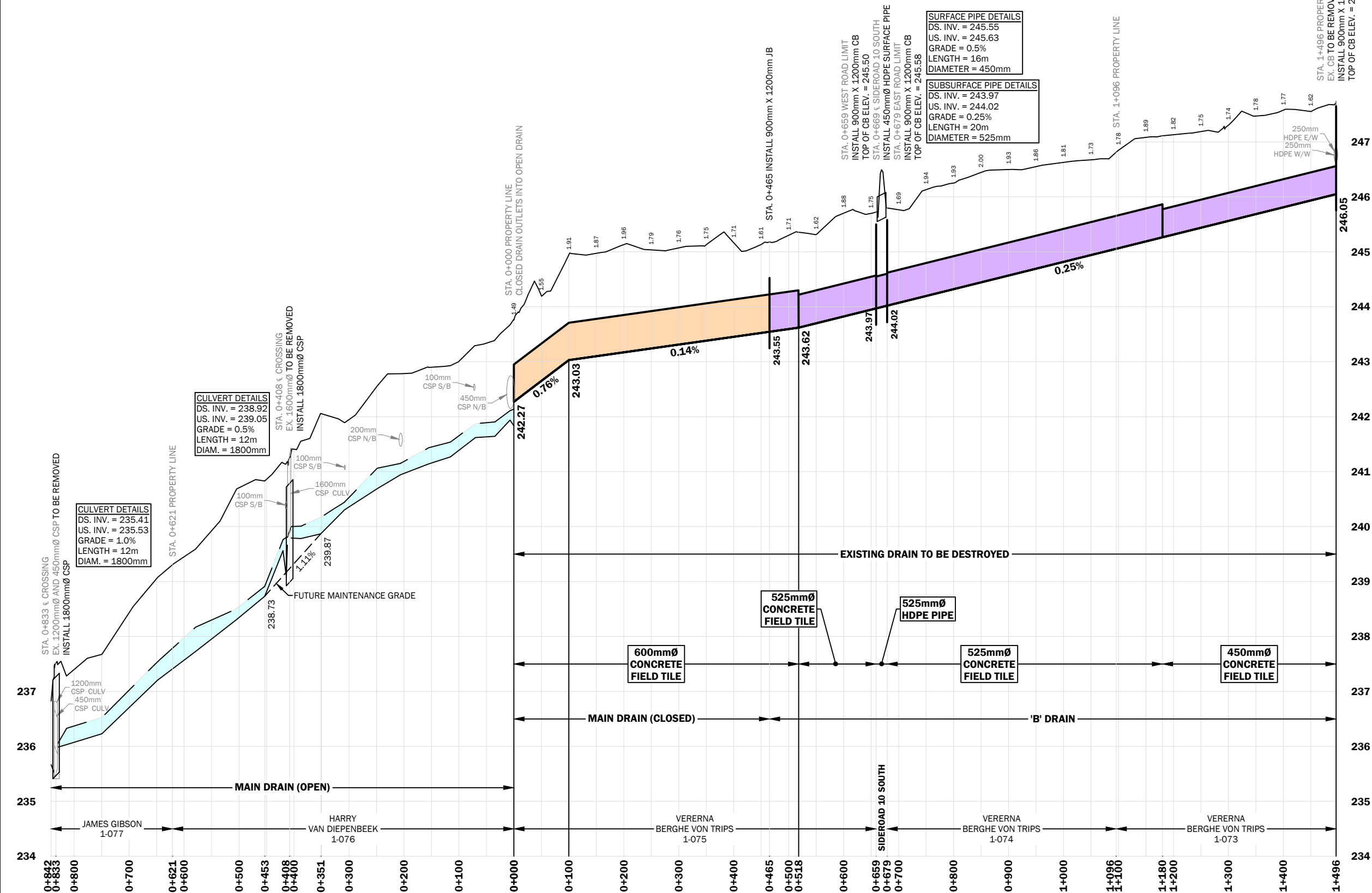

SCHEDULE OF PIPE MATERIALS

MATERIAL	DIAMETER (mm)	STATION RANGE	LENGTH (m)
1. HIGH DENSITY POLYETHYLENE OUTLET PIPE	600	0+000 - 0+006	6
2. CONCRETE FIELD TILE	600	0+006 - 0+518	512
3. CONCRETE FIELD TILE	525	0+518 - 0+659	141
4. HIGH DENSITY POLYETHYLENE PIPE	525	0+659 - 0+679	20
5. CONCRETE FIELD TILE	525	0+679 - 1+180	501
6. CONCRETE FIELD TILE	450	1+180 - 1+496	316

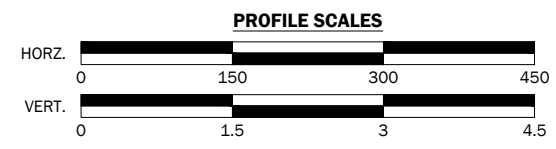

No.	REVISION	DATE (YY-MM-DD)
3	REPORT SUBMISSION	23-09-15
2	INFORMATION MEETING	23-04-27
1	ON-SITE MEETING	22-07-12



DRAWN BY: R.U.	DESIGNED BY: A.H.	CHECKED BY: S.B.
DATE: 2023-09-15	REFERENCE No. HK-004	DRAWING No. 2 OF 3



NOTES:

1. THIS MAP WAS CREATED USING COUNTY OF BRUCE GEOGRAPHIC INFORMATION SYSTEM DIGITAL DATA. THIS MAP IS A SECONDARY PRODUCT WHICH HAS NOT BEEN VERIFIED BY THE COUNTY OF BRUCE.
2. THE CONTOURS WERE CREATED USING IMAGERY DERIVED DIGITAL DATA (2015) FROM LAND INFORMATION ONTARIO.

BENCHMARK DESCRIPTIONS

- BENCHMARK No. 1** ELEV.=242.74
TOP OF 450mmØ CSP OUTLET PIPE AT STA. 0+000 (MAIN DRAIN)
- BENCHMARK No. 2** ELEV.=247.40
TOP DOWNSTREAM END OF 450mmØ LANEWAY CULVERT 168m NORTH OF STA. 1+100 ('B' DRAIN)

LEGEND

- PROPERTY LINE
- OVERLAND FLOW PATH
- BENCHMARK LOCATION
- B.M. 1 123.45 BENCHMARK No.
- BENCHMARK ELEVATION
- JOHN & JANE SMITH 12-345 LANDOWNER NAME(S)
- ASSESSMENT ROLL No. (ABBREVIATED)
- AREA WITHIN WATERSHED (12.3 Ha.)

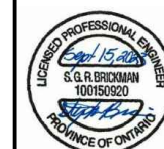

No.	REVISION	DATE (YY-MM-DD)
3	REPORT SUBMISSION	23-09-15
2	INFORMATION MEETING	23-04-27
1	ON-SITE MEETING	22-07-12



DRAWN BY: R.U.	DESIGNED BY: A.H.	CHECKED BY: S.B.
DATE: 2023-09-15	REFERENCE No. HK-004	DRAWING No. 3 OF 3

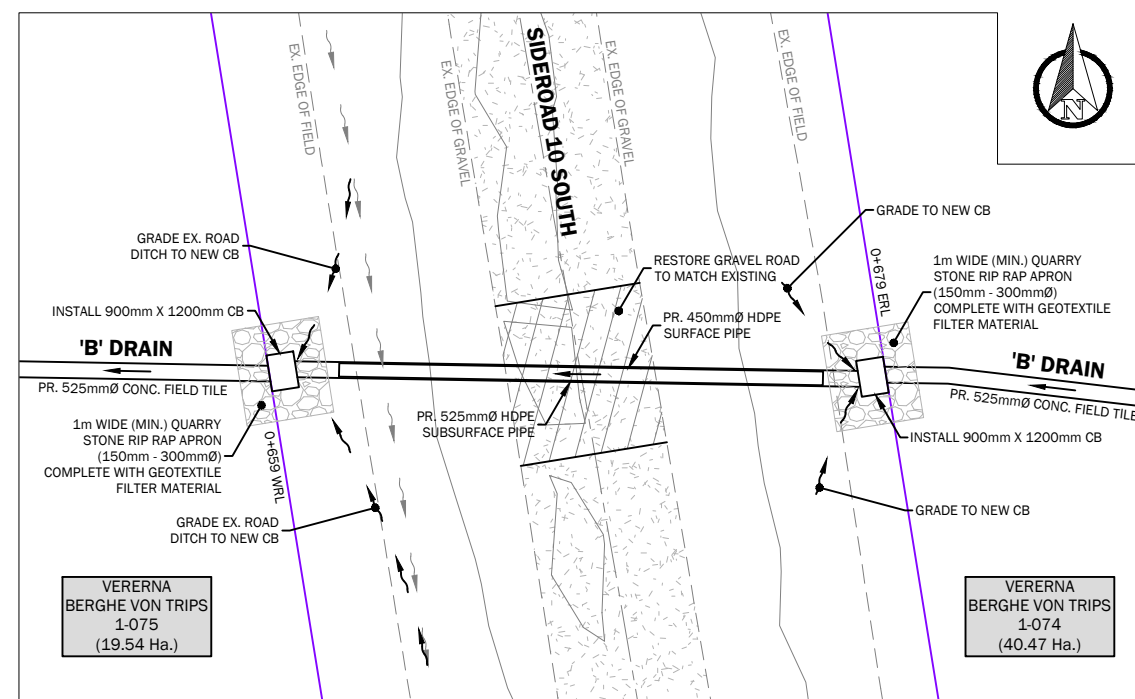

SIDEROAD 10 SOUTH CROSSING DETAIL PLAN SCALE

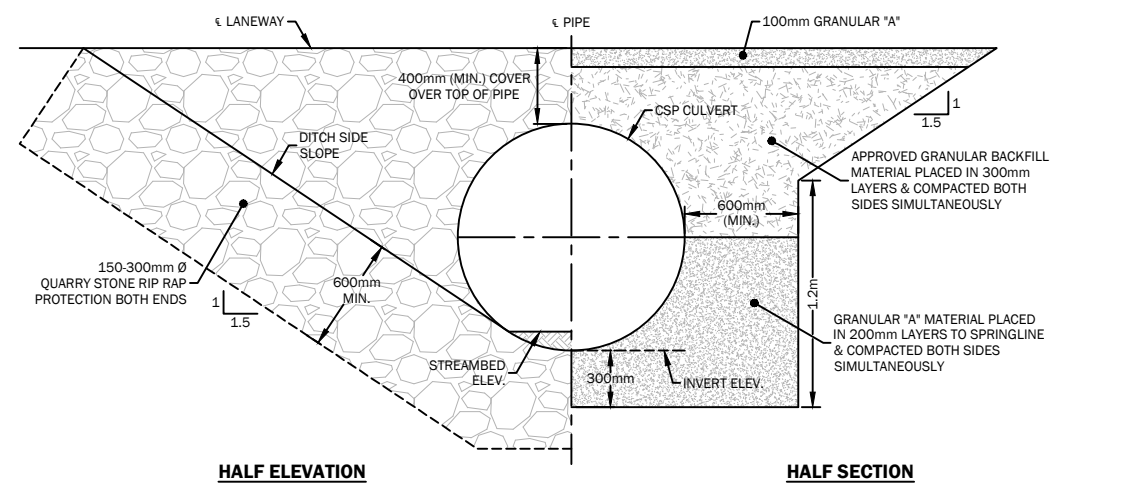

HALF ELEVATION

HALF SECTION

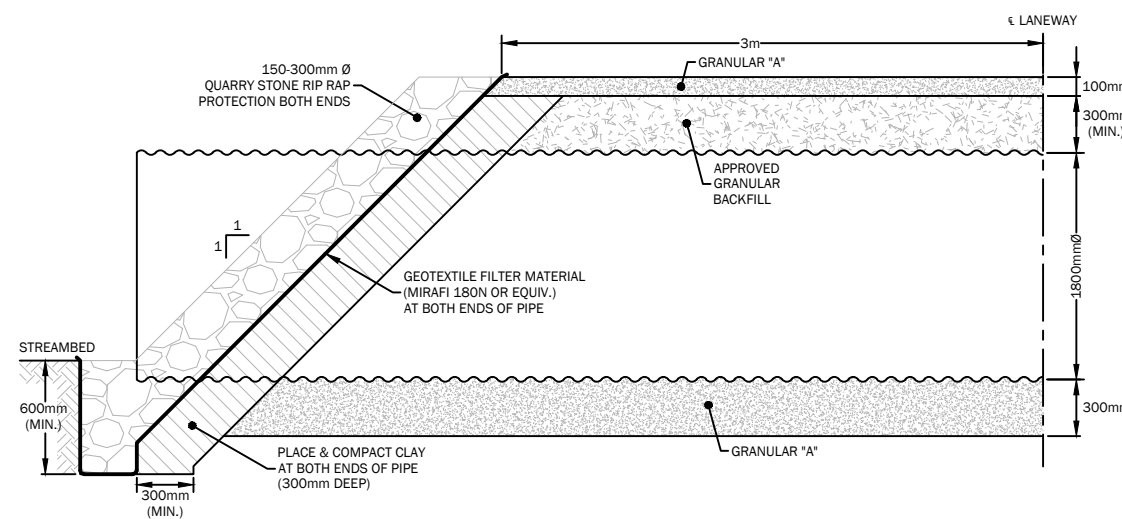

HALF LONGITUDINAL SECTION

STATION	DIAMETER	LENGTH	INVERT	STREAMBED	CORRUGATIONS	THICKNESS
0+408	1800mm	12m	DS. = 238.92 US. = 239.05	DS. = 239.17 US. = 239.30	125mm X 25mm	2.80mm
0+833	1800mm	12m	DS. = 235.41 US. = 235.53	DS. = 235.66 US. = 235.78	125mm X 25mm	2.80mm

TYPICAL LANEWAY CULVERT DETAIL N.T.S.

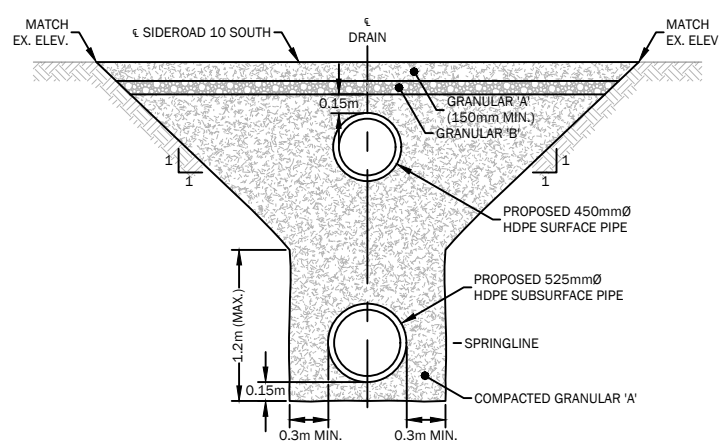

SIDEROAD 10 SOUTH CROSSING SECTION N.T.S.

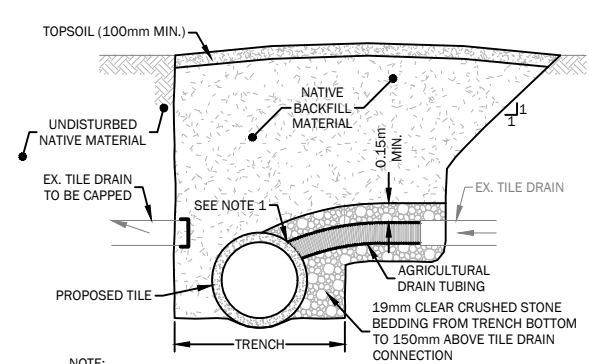

TYPICAL TILE CONNECTION DETAIL N.T.S.

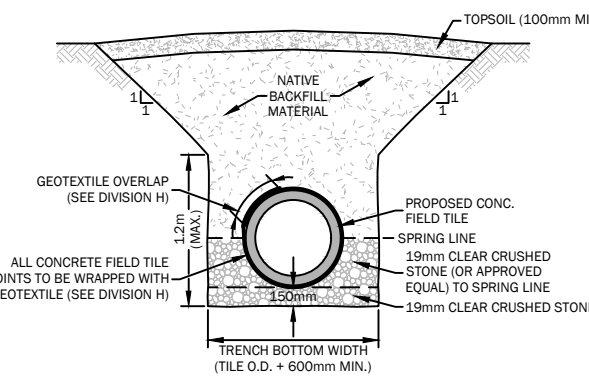

TYPICAL CONCRETE TILE INSTALLATION ON STONE BEDDING DETAIL (PROVISIONAL ITEM) N.T.S.

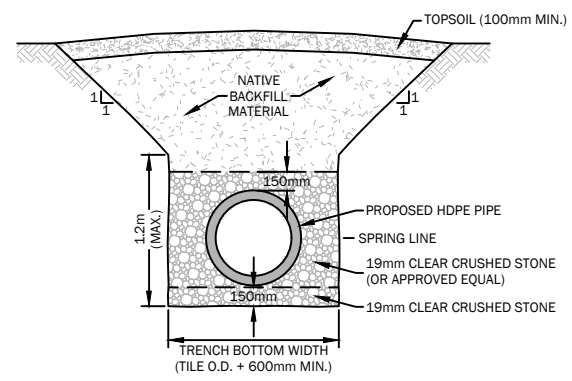

TYPICAL HDPE PIPE INSTALLATION ON STONE BEDDING DETAIL N.T.S.

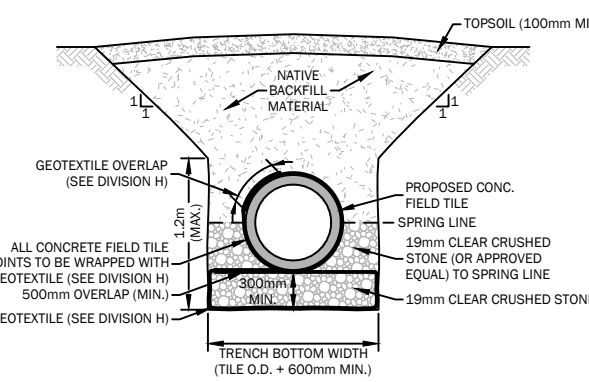

TYPICAL CONC. TILE INSTALLATION ON WRAPPED STONE BEDDING DETAIL (PROVISIONAL ITEM) N.T.S.

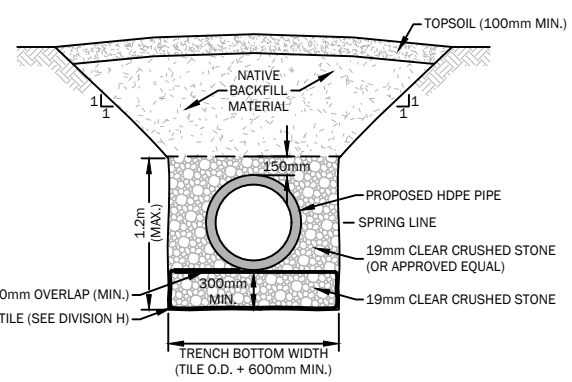

TYPICAL HDPE PIPE INSTALLATION ON WRAPPED STONE BEDDING DETAIL (PROVISIONAL ITEM) N.T.S.

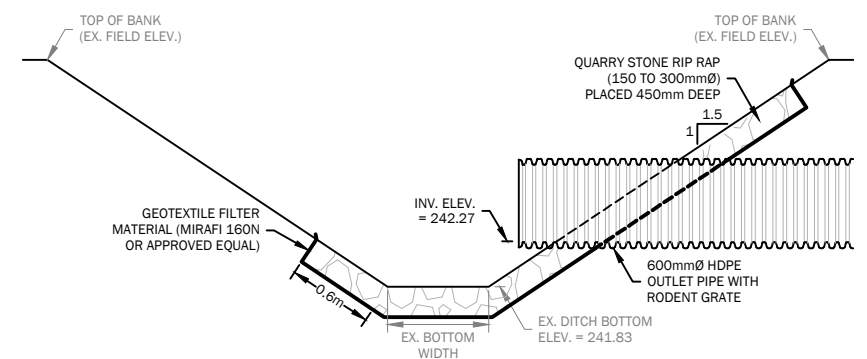

TYPICAL OUTLET DETAIL N.T.S.