

ENGINEERING REPORT

For

GAUNT-LAIDLAW MUNICIPAL DRAIN

Township of Huron-Kinloss

Geographic Township of Kinloss

Bruce County

Date: November 29, 2024

File No. 22-160



K. SMART ASSOCIATES LIMITED
CONSULTING ENGINEERS & PLANNERS

85 McIntyre Drive
Kitchener, ON N2R 1H6

Tel: 519-748-1199
Fax: 519-748-6100

This page intentionally left blank

TABLE OF CONTENTS

1 EXECUTIVE SUMMARY 1

2 BACKGROUND 2

3 DRAINAGE HISTORY 2

4 INVESTIGATION 3

 4.1 On-Site Meeting 3

 4.2 Site Examination and Survey 3

 4.3 Watershed Description 4

5 AUTHORITY FOR REPORT 4

6 DESIGN CONSIDERATIONS 5

 6.1 Sufficient Outlet 5

 6.2 Drain Capacity 5

 6.3 Soil Conditions 5

7 MEETING(S) 6

8 ENVIRONMENTAL CONSIDERATIONS 6

 8.1 Agency Notification 6

 8.2 Agency Responses 6

9 RECOMMENDED WORK 7

10 CONSTRUCTION CONSIDERATIONS 7

 10.1 Construction Scheduling 7

 10.2 Design Changes During Construction 7

 10.3 Alignment of Drains 8

11 DRAWINGS AND SPECIFICATIONS 8

 11.1 Drawings 8

 11.2 Specifications 8

12 COST ESTIMATE 8

 12.1 Allowances 8

 12.2 Construction Cost Estimate 10

 12.3 Engineering Cost Estimate 10

 12.4 Estimate of Section 73 Costs 11

 12.5 Harmonized Sales Tax 11

 12.6 Estimated Cost Summary 12

13 ASSESSMENTS 14

 13.1 Calculation of Assessments 14

 13.2 Benefit Assessments (Section 22 and 24) 14

 13.3 Outlet Liability Assessments (Section 23) 15

 13.4 Assessment Schedules 15

14 GRANT 16

15 PRIVACY OF LANDS 17

16 MAINTENANCE 17

 16.1 General 17

 16.2 Updating Future Maintenance Schedules 18

17 BY-LAW 18

SCHEDULE A – SCHEDULE OF ASSESSMENTS

SCHEDULE B – SCHEDULE OF ASSESSMENTS FOR MAINTENANCE

SCHEDULE C – SCHEDULE FOR ACTUAL COST BY-LAW

APPENDIX A – CALCULATION OF ASSESSMENTS

APPENDIX B – CALCULATION OF ASSESSMENTS FOR FUTURE MAINTENANCE

STANDARD SPECIFICATIONS

- Section 200 - General Conditions
- Section 300 - Special Provisions (See Drawings 2, 3, 4 & 7)
- Section 400 - Standard Specifications for Construction of Drains
- Section 410 - Standard Specifications for Open Drains
- Section 420 - Standard Specifications for Tile Drains

DRAWINGS 1 TO 7

Definitions:

- "Act" means The Drainage Act RSO 1990
- "CSP" means corrugated steel pipe
- "Drain" means Gaunt-Laidlaw Municipal Drain
- "Grant" means grant paid under the Agricultural Drainage Infrastructure Program
- "HDPE" means high-density polyethylene
- "Municipality" means Township of Huron-Kinloss
- "OMAFRA" means the Ontario Ministry of Agriculture, Food and Rural Affairs
- "MECP" means Ministry of Environment, Conservation and Parks
- "MNR" means Ministry of Natural Resources and Forestry
- "DFO" means Fisheries and Oceans Canada
- "Tribunal" or "Drainage Tribunal" means Agriculture, Food and Rural Affairs Appeal Tribunal

Table 12.1-1 - Section 29 Allowance Rates 9

Table 12.1-2 - Section 30 Allowance Rates 9

Table 12.1-3 - Section 31 Allowances 9

Table 12.1-4 - Summary of Allowances 10

Table 12.6-1 - Estimated Cost Summary 12

Table 13.2-1 - Benefit Assessments 15

Table 13.3-1 - Runoff Factors Table 15



K. SMART ASSOCIATES LIMITED

CONSULTING ENGINEERS & PLANNERS

85 McIntyre Drive
Kitchener, ON N2R 1H6

Tel: 519-748-1199
Fax: 519-748-6100

November 29, 2024

File No. 22-160

GAUNT-LAIDLAW MUNICIPAL DRAIN TOWNSHIP OF HURON-KINLOSS

1 **EXECUTIVE SUMMARY**

This report is prepared pursuant to Section 78 of the Drainage Act RSO 1990 (the Act).

On April 20, 2022, the Township of Huron-Kinloss received a petition for extension and improvement in Lots 27 and 28, Concession 2 for the Gaunt-Laidlaw Municipal Drain under Section 4 and 78 of the Drainage Act. Pursuant to Section 8 of the Act, on April 28, 2022, K. Smart Associates Limited was appointed by resolution of Council to prepare a report on the petition received.

At the Consideration of the Report meeting on August 14, 2023, the report dated June 30, 2023 was referred back to the engineer to extend the drain through Roll Number 00-2216-00, to collect surface water from the neighbouring property.

To address the petition/request received, this report recommends the following:

- Excavation of 282m, and incorporation of 743m of open ditch.
- Installation of 432m of closed drain and 497m of overflow swale.

The estimated cost of this project is \$186,820.

The watershed served is approximately 60.6 hectares (149.7 acres).

Assessment schedules are for construction and future maintenance of the drainage works.

- Schedule A shows the assessment of the total estimated cost.
- Schedule B is for prorating future maintenance cost.
- Schedule C is for levying the final cost of the Drain.
- Appendix A illustrates the calculation of the assessments outlined in Schedule A.
- Appendix B illustrates the calculation of the assessments outlined in Schedule B.

2 **BACKGROUND**

On April 20, 2022, the Township of Huron-Kinloss received a petition from Michael and Tina Metske, and Harvey and Sarah Martin for extension and improvement in Lots 27 and 28, Concession 2 for the Gaunt-Laidlaw Municipal Drain under Sections 4 and 78 of the Drainage Act. Pursuant to Section 8 of the Act, on April 28, 2022, K. Smart Associates Limited was appointed by a resolution of the Council to prepare a report on the petition received.

3 **DRAINAGE HISTORY**

The Gaunt-Laidlaw Municipal Drain was originally established in accordance with a report by J. C. Monteith, O.L.S., dated December 5, 1929. The final By-law was given on September 1, 1930. Under the 1929 report, the 4" tile starts at South Kinloss Avenue near the edge of lot 27 and Lot 28, Concession 2 and heads northerly and crosses into Lot 28, then crosses back to Lot 27 before it outlets into an open ditch. The drain consists of approximately 382m of 100mm diameter tile and 302m of 200mm diameter tile.

Proposed New Stations	Roll Number	1929 Stations in Metres	1929 Items	Proposed Work	Status
1+288 to 0+545	00-2113-00	N/A	N/A	Incorporate natural channel	Part of Drain
0+450 to 0+257	00-2115-00 and 00-2113-00	N/A	N/A	Open Ditch	Part of Drain
0+257 to 0+130	00-2115-00	N/A	N/A	525mm and 375mm	Part of Drain
0+130 to 0+000	00-2115-00	0+544 to 0+684	200mm Tile	290mm and 250mm	Part of Drain
0+000 to -0+169	00-2116-00	0+382 to 0+544	200mm Tile	150mm HDPE	Part of Drain
-0+169 to -0+238	00-2116-00	0+306 to 0+382	100mm Tile	No work	Abandon
-0+238 to -0+544	00-2115-00	0+000 to 0+306	100mm Tile	No work	Abandon

4 **INVESTIGATION**

4.1 **On-Site Meeting**

On June 28, 2022, an on-site meeting was held in accordance with Sections 9(1) and 9(2) of the Act. Notice of the meeting was sent to the petitioners/landowners most affected by the drain/all landowners believed to be in the watershed and the affected agencies. The following attended the on-site meeting:

Joanne Whytock (Roll No. 00-2101-000)	Harvey Martin (Roll No. 00-2115-000)
Mike Metske (Roll No. 00-2116-000)	John Yungblut, Township of Huron-Kinloss, Director of Public Works
Neal Morris, P. Eng., Project Engineer, K. Smart Associates Limited	

The following input was provided by those in attendance:

Joanne Whytock (Roll No.00-2101-000)

Joanne indicated that their property is outside of the watershed. Their land is drained to the south and west and does not cross South Kinloss Avenue.

Mike Metske (Petitioner Roll No. 00-2116-000)

Their land is tiled, but the Gaunt-Laidlaw Drain is currently not working. The tiles are underwater, and they need a new tile. They have a 6" tile and 1 x 4' clay tile from the property. He would like a 1.5" to 2" drainage coefficient. Their soils are sandy. He indicated that no water comes from the east of their property. There are some stones near the catchbasin. They just want a tile outlet and catchbasin.

Harvey Martin (Petitioner Roll No. 00-2115-000)

They grow hay and a little corn on their property. The south of their property is tiled to the west. He indicated that the Gaunt-Laidlaw Drain tile is not needed to the south. They installed a 16" smooth tile along the bush in the downstream section last year. The land along Dickies Creek is muck and can be hard to dig. There are many beaver dams in Dickies Creek.

John Yungblut

The Township has no concerns.

4.2 **Site Examination and Survey**

The route of the existing drain was examined after the on-site meeting. A topographic survey was completed on October 12, 2022, from the Drain outlet to Station -0+238.

4.3 Watershed Description

The perimeter watershed of the Drain has been established based on on-site investigation, GIS DEM SWOOP data, topographic information and historical reports.

The watershed area is approximately 81.9% agricultural lands and 18.1% forest.

5 AUTHORITY FOR REPORT

While the Gaunt-Laidlaw Drain is an existing drain, there was no evidence of the existing drain being functional. Section 4 of the Drainage Act provides for the construction of new drainage works for an area requiring drainage. As a result of discussions at the on-site meeting and the on-site examination, the area requiring drainage was determined to be the currently tiled land into the historical Gaunt-Laidlaw Drain part of Concession 2, Lots 27 and 28 .

A sketch of the area requiring drainage is presented below. The signatures on the petition account for all of the 50.4ha area requiring drainage. The signatures on the petition account for 100% of the properties in the area requiring drainage. Thus, the petition is valid under Sections 4(1)(a) and (b) of the Drainage Act.

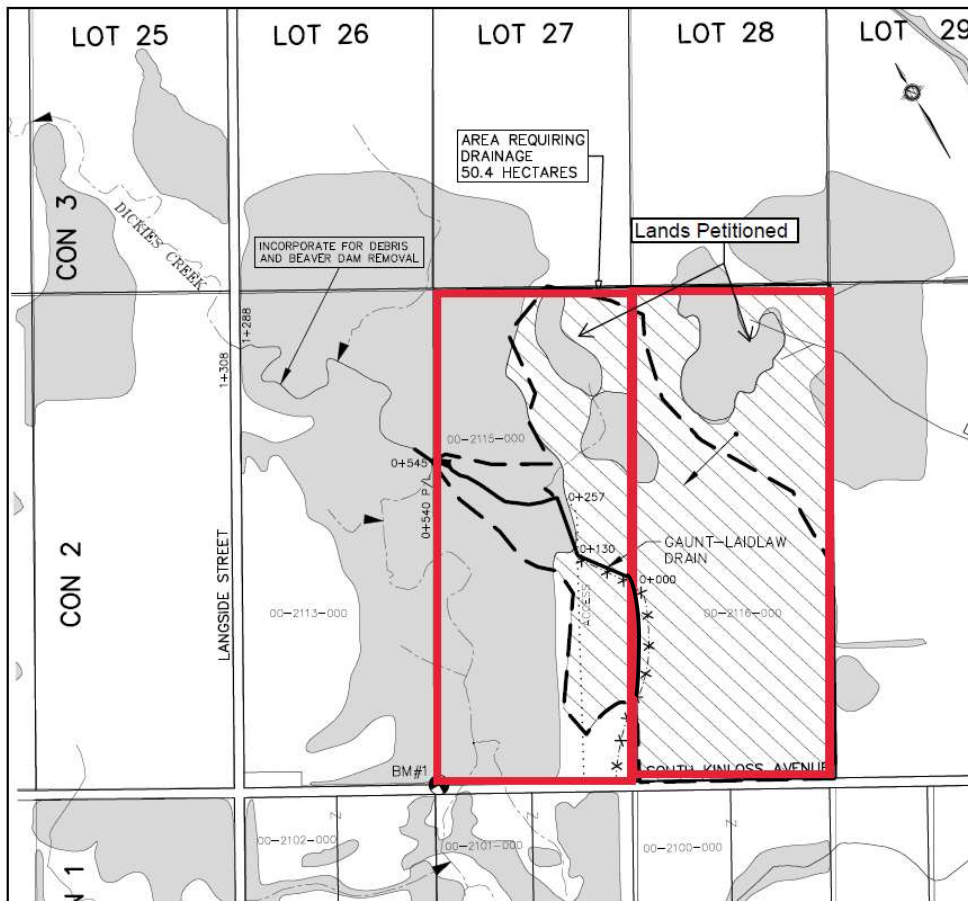

6 DESIGN CONSIDERATIONS

6.1 Sufficient Outlet

Section 15 of the Act requires that the proposed work be continued downstream to a sufficient outlet. Section 1 of the Act defines sufficient outlet as "a point at which water can be discharged safely so that it will do no damage to lands or roads." For this project, Station 1+288 on the Main Drain provides sufficient outlet and will allow the proposed works to function as intended. While the main work will stop at Station 0+545, the 743m of the Dickies Creek was incorporated to ensure that the tile outlet at Station 0+257 would not be impacted by Dickies Creek. The Dickies Creek section will be incorporated for debris and beaver dam removal so the tile outlet is not underwater.

6.2 Drain Capacity

The open ditch portion of the Drain is designed to provide adequate depth for tile drain outlets and will also convey the 2-year storm within the channel cross-section. It is customary to design open municipal drains serving agricultural or rural lands for a 2-year storm.

The size of the proposed tile drain was determined using the Drainage Coefficient Method outlined in the *Drainage Guide for Ontario*, published by OMAFRA. The drainage coefficient is a measure of the amount of runoff that a closed drain can remove from an upstream watershed in a 24-hour period. Based on our watershed examination and landowner discussions, the proposed tile drains on this project have been designed for a 1.5" drainage coefficient.

6.3 Soil Conditions

The Bruce County soils mapping for this area indicates that the soils adjacent to this Drain are Fox Sandy Loam with Muck soils in low and open ditch areas.

Based on available information, adverse subsurface and soil should be anticipated. New tile may be placed into saturated sandy soils. Clear stone and filter fabric rip-rap may be required in poor-subsoil conditions.

It is to be anticipated that the open ditch will be constructed in Muck soils. Muck soils have a low bearing capacity and are saturated soils. Work in the winter or in the summer dry, is recommended. Construction equipment most likely would be required to be supported with mats or trees during construction.

Refer to the Standard Specifications for drain construction procedures when adverse subsurface conditions are encountered.

7 **MEETING(S)**

On April 12, 2023, a second meeting with landowners was held. Notice for the meeting was sent to landowners directly affected by the proposed work/all landowners in the watershed, Maitland Valley Conservation Authority and the Municipality. At the meeting, the results of the investigation to-date were presented along with a summary of the proposed work/design alternatives and preliminary cost estimates and assessments.

Those present at the meeting were in general agreement with the work proposed.

8 **ENVIRONMENTAL CONSIDERATIONS**

8.1 Agency Notification

Contact was made with the Maitland Valley Conservation Authority and DFO during the process of preparing this report.

8.2 Agency Responses

8.2.1 Maitland Valley Conservation Authority (MVCA)

The Maitland Valley Conservation Authority did not request an environmental appraisal under Section 6 of the Act. The Conservation Authority were sent notices to the public meetings. A permit application and drawings was e-mailed to MVCA on May 8, 2023. A response from the Conservation Authority, dated May 8, 2023, indicated that additional comments would be coming.

8.2.2 MNRF

As there are no species at risk in the area, no screening request for species at risk was submitted to MNRF.

8.2.3 DFO

The Gaunt-Laidlaw Municipal Drain is rated Class F under DFO's drain classification system. Dickies Creek is rated Class D under DFO's drain classification system, and there is no proposed work on this portion of the the drain.

A Request for Review was submitted to DFO along with a project description, drawing package and photo log dated May 4, 2023. The response from DFO, dated June 8, 2023, indicated that

- No in-water work to occur between March 15 – July 15.
- Limit access to banks or areas adjacent to waterbodies.
- Construct access points and approaches perpendicular to the watercourse or waterbody.
- Vegetate the disturbed area with native species suitable for open ditch.
- Conduct all in-water works, undertakings or activities in isolation of open or flowing water to reduce the introduction of sediment into the watercourse.
- The DFO code of practice for temporary cofferdams and diversion channels should be used.
- Work in open ditch is not to occur in rainy, spring melt, stormy and windy weather.

- Monitor the watercourse to observe signs of sedimentation during all phases of the work, undertaking or activity and take corrective action.
- Place existing stream bed and bank material in bank in ditch after work is completed.
- Contractor is to clean equipment and have a spill kit on-site before working in open ditch.

8.2.4 MECP

There are no SAR anticipated in the area of proposed work.

9 **RECOMMENDED WORK**

Further detail regarding the construction and maintenance of the Drain is in the Special Provisions and Drawings.

10 **CONSTRUCTION CONSIDERATIONS**

10.1 Construction Scheduling

Construction cannot commence until ten days after a by-law to adopt this report is given third reading in accordance with the Act.

On this project, it is anticipated that no permits will be required prior to starting construction.

10.2 Design Changes During Construction

In general, design changes requested by landowners, agencies or other authorities after the by-law is passed cannot be undertaken.

Section 84.1 of the Act and the associated regulation, O. Reg. 500/21, provides criteria and a process for amending this report if design changes are required during construction and approved by the engineer. If design changes are made, this report must be amended after construction with the as-constructed drawings before passing the actual cost by-law. Since allowances were given in the original 1929 report, ROW allowances were only given for new sections of the drainage the open ditch work.

Additional work desired by the landowner(s) which is not part of the drainage works may be arranged with the Contractor provided the cost of the work is paid by the landowner(s), and the engineer reviews the additional work in advance. Such additional work is not part of the drainage works for future maintenance.

10.3 Alignment of Drains

All drains shall be constructed and maintained generally to the alignment, as noted on the plans and specified by the Special Provisions. In the absence of survey bars, existing fences and similar boundary features are assumed to represent property lines. Should landowners desire a more precise location for the drains in relation to their property line or if there is a dispute about the location of any property line, landowners may obtain a legal survey at their own cost before construction.

11 DRAWINGS AND SPECIFICATIONS

11.1 Drawings

The location of the Drain, watershed boundary and the affected properties are shown on Drawing No. 1 included with this report. The numbers adjacent to the Drain are station numbers, which indicate in metres the distance along the Drain from the outlet.

The profiles for the Drain are on Drawing No. 2. The profiles show the depth and grade for proposed work and future maintenance.

Drawings No. 2, 3, 4 and 7 contain the Special Provisions.

11.2 Specifications

This report incorporates the General Conditions, Standard Specifications and Special Provisions listed in the Table of Contents, which govern the construction and maintenance of the Drain.

12 COST ESTIMATE

This report incorporates the General Conditions, Standard Specifications and Special Provisions listed in the Table of Contents, which govern the construction and maintenance of the Drain. The estimated cost of this project includes allowances to owners, the construction cost, the engineering cost and other costs associated with the project.

12.1 Allowances

Sections 29 to 33 of the Drainage Act provides for allowances (compensation) to owners affected by proposed drain construction. On this project, there are allowances for Sections 29, 30 and 31.

12.1.1 Section 29 – Right-of-Way

Section 29 provides for payment of an allowance to landowners for the right-of-way required for construction and maintenance of the new Drain. This allowance compensates the owners for land to accommodate the Drain, access routes to the Drain and for a corridor along the Drain for construction and maintenance purposes. Right-of-way corridors of equal width exist along both sides of the Drain for maintenance. Current municipal assessment rolls were reviewed to establish land

values for computing right of way allowances. The 1929 Gaunt-Laidlaw Drain Report included Right-of-Way allowances so no Right-of-way allowances were given for tile installed along the 1929 Gaunt-Laidlaw Drain Report. Section 29 allowances are based on the following rates:

Table 12.1-1 - Section 29 Allowance Rates

Land Use	Area Land Value
Cultivated Lands	\$ 19,100/ha
Bush Lands	\$ 9,550/ha

12.1.2 Section 30 - Damages

Section 30 provides for payment of an allowance to landowners along the Drain for damages caused by the construction of the Drain. Where separate access routes to the working area are specified in this report, Section 30 allowances also account for access route damage. In agricultural areas, crop damages are computed based on published crop values and declining productivity loss in the years following construction. For this project, Section 30 allowances are based on the following rates:

Table 12.1-2 - Section 30 Allowance Rates

Land Use	Area Land Value
Cultivated Lands Tile installation	\$ 1,690/ha
Bush Lands Open Ditch	\$1,690/ha
Old Farm Fence	\$ 5/m

12.1.3 Section 31 – Existing Drains

Section 31 provides for payment of an allowance to the owner of an existing drain that is to be incorporated as part of the new Drain. The allowance for incorporating the existing tile on the Harvey Martin property (Roll No 00-2115-000) was 127m of 375mm HPDE pipe and 130m of 250mm HDPE pipe..

Table 12.1-3 - Section 31 Allowances

Roll Number	Item	Est. Pipe Cost (\$)	Discount (%)	Allowance (\$)
00-2115-000	127m of 375mm HDPE Pipe	\$65/m	0.15	1,200
00-2115-000	130m of 250mm HDPE Pipe	\$45/m	0.15	900

12.1.4 Section 32 – Insufficient Outlet

Section 32 provides for payment of an allowance to owners affected when a drain is not constructed to a sufficient outlet. The proposed Drain is constructed to sufficient outlet, so no allowance is required under Section 32.

12.1.5 Section 33 – Loss of Access

Section 33 provides for payment of a loss of access allowance to a property where an open drain is constructed, and a crossing is not provided for the property. The proposed Drain does not create a loss of access on any property, so no allowance is required under Section 33.

The table below summarizes the dimensions and amounts of the allowances to be provided under this report.

12.1.6 Summary of Allowances

Table 12.1-4 - Summary of Allowances

Roll Number	R.O.W. Width (m)	Sec.29 (\$)	Damages Width (m)	Sec.30 (\$)	Existing Sec. 31 (\$)	Total (\$)
00-2113-000	10	3,500	25	-	-	3,500
00-2115-000	10	2,550	25	50	2,100	4,700
00-2116-000	10	800	25	950	-	1,750
TOTAL ALLOWANCES:		6,850		1,000	2,100	9,950

In accordance with Section 62(3) of the Act, the allowances shown may be deducted from the final assessment levied. Payment to the owner would only be made when the allowance is greater than the final assessment. The allowances are a fixed amount and are not adjusted due to construction.

12.2 Construction Cost Estimate

The estimated cost for Labour, Equipment and Materials to construct the proposed Drain is outlined in detail in Estimated Costs Summary in Table 12.6-1 - Estimated Cost Summary. The construction cost estimate is based on recent costs for comparable work. A contingency amount is included to cover additional work that may be required due to field conditions or minor alterations to the project.

The contract for the Drain will be awarded by public tender. If the contract price is more than 33% over the engineer's estimate, Section 59 of the Act requires a Council meeting with the petitioners to determine if the project should proceed.

12.3 Engineering Cost Estimate

Engineering costs include report preparation and attending the Council meeting to consider the report and the Court of Revision

Construction Phase Services may include: preparing tender documents and tender call, review of tenders, attending the pre-construction meeting, periodic construction

inspection, payments, final inspection, post-construction follow-up, final cost analysis and preparation of the grant application.

The cost for report preparation is usually not altered at the conclusion of a project unless the report is referred back or the report is appealed to the Drainage Tribunal, which would result in additional costs. The amount shown for meetings is an estimate. The final cost will be based on the actual time required for meetings. The estimate shown for construction phase services is based on experience and assumes good construction conditions and a Contractor who efficiently completes the construction. The final cost for the construction phase will vary as per the actual time spent during and following drain construction. Engineering costs are summarized in Table 12.6-1 - Estimated Cost Summary.

12.4 Estimate of Section 73 Costs

Section 73(2) and 73(3) of the Act direct that the cost of services provided by municipal staff and the Council to carry out the Act process shall not form part of the final cost of the Drain. However, Section 73(1) outlines that the following costs incurred by the Municipality can be included in the cost of the Drain: "*cost of any application, reference or appeal and the cost of temporary financing.*"

The estimate of Section 73 costs is included to cover the above-referenced items from Section 73(1) and primarily provides for interest charges on financing the project until it is completed. This cost estimate may not be adequate to cover legal or engineering costs incurred by or assessed to the Municipality should the project be appealed beyond the Court of Revision though such costs will form part of the final drain cost.

Grant policy indicates that municipal cost for photo-copying and mailing required to carry out the required procedures under the Act can be included in the final drain cost. Section 73 costs are summarized in Table 12.6-1 - Estimated Cost Summary.

12.5 Harmonized Sales Tax

The Harmonized Sales Tax (HST) will apply to most costs on this project. The Municipality is eligible for a partial refund on HST paid, the net 1.76% HST is included in the cost estimates in this report.

12.6 Estimated Cost Summary**Table 12.6-1 - Estimated Cost Summary**

DESCRIPTION						TOTAL COST
ALLOWANCES:						\$9,950
CONSTRUCTION COST ESTIMATE						
Item	Stations	Description	Unit	Quantity	Unit Price	Cost
i) Main Drain						
1	0+000	Install 600x600mm concrete ditch inlet catchbasin and connect existing 375mm concrete tile to catchbasin with 5m ² or rip-rap	L.S.	1	3,000	3,000
2	0+002	Construct WASCoB, 60m long and 1m wide top berm with 4:1 side slopes. Install 15m ² of rip-rap	L.S.	1	9,700	9,700
3	-0+001	Remove 2.5m of existing 375mm concrete culvert	L.S.	1	300	300
4	0+002	Remove 60m of existing fence	L.S.	1	500	500
5	0+001 to 0+130	Regrade 129m of overflow swale, 1m bottom, 10:1 side slopes	m	129	15	1,900
6	0+001 to 0+130	Seed disturbed area (10m width)	m ²	1,290	2	2,600
7	0+000 to 0+130	Install 130m of 350mm concrete tile	m	130	51	6,600
8	0+130	Remove existing 750mm dia. catchbasin and install 1200x900mm catchbasin with 5m ² riprap around catchbasin. Connect two existing 200mm plastic, 250mm plastic and 375mm concrete tile to catchbasin	L.S.	1	5,000	5,000
9	0+130 to 0+257	Regrade 127m of overflow swale, 1m bottom, 10:1 side slopes	/m	127	15	1,900
10	0+130 to 0+257	Seed disturbed area (10m width)	m ²	1,270	2	2,500
11	0+130 to 0+257	Install 127m of 525mm concrete tile	/m	127	66	8,300
12	0+257	Install 1200x900mm ditch inlet catchbasin with 5m ² riprap around DICB. Connect existing 150mm, 200mm and 375mm plastic pipes to catchbasin.	L.S.	1	5,000	5,000
13	0+257 to 0+263	Install 6m of 600mm HDPE pipe	m	6	390	2,300

DESCRIPTION							TOTAL COST
14	0+260	Construct WASCoB, 30m long and 1m wide top berm, 2:1 side slope, 4:1 back slope	L.S.	1	5,800	5,800	
15	0+257 to 0+263	Backfill existing ditch and taper banks to 5:1, approximately 15m ³ of fill needed.	L.S.	1	2,000	2,000	
16	0+263 to 0+545	Brushing 10m wide on north side of ditch	m ²	2,820	1.5	4,200	
17	0+263 to 0+545	Excavate ditch, 1m bottom, 2:1 side slopes. Place spoils on north side of ditch	m	282	30	8,500	
18	0+263 to 0+545	Seed banks (10m width)	m ²	2,820	2	5,600	
19	0+263 to 0+268	Construct 5m long permanent sediment trap with 20m ² of rip rap	L.S.	1	2,500	2,500	
20	0+545 to 1+288	Incorporate 743m Dickies Creek for debris and beaver Dame removal, existing natural cross-section to be maintained	m.	743	0	0	
21	-0+169 to 0+000	Install 169m of 150mm HDPE	m	169	35	5,900	
22	-0+169	Construct 600x600 concrete DICB and 5m ² of rip-rap	m	1	2,500	2,500	
23	-0+170 to -0+169	Construct WASCoB, 38m long and 1m wide top berm, 2:1 side slope, 4:1 back slope, with 10m ² of rip-rap	m	1	5,000	5,000	
24	-0+150 to 0+000	Incorporate 150m of overflow swale 1m bottom and 10:1 side slopes	m	150	0	0	
25	-0+241 to -0+150	Regrade 91m of existing swale 1m bottom 1:10 side slope	m	91	20	1,800	
26	-0+241 to -0+150	Seed disturbed 910m ²	m ²	910	2	1,800	
Sub Total Part i)						95,200	
ii) Contingencies							
24		Lump sum contingency allowance	L.S.	1	8,500	8,500	
Net HST (1.76%)						1,825	
TOTAL CONSTRUCTION COST ESTIMATE:							\$105,525
ENGINEERING COSTS							
Report Preparation						33,000	
Prepare updated Report						12,000	
2x Consideration of Report Meeting						3,000	
Court of Revision						1,500	
Construction Phase Services						15,600	

DESCRIPTION	TOTAL COST
Net HST (1.76%)	1,145
TOTAL ENGINEERING COSTS:	\$66,245
SECTION 73 COSTS	
Printing of reports x 2	300
Printing of tenders	200
Agencies Permit Fee	235
Interest estimate	0
Unforeseen costs	4,280
Net HST (1.76%)	85
TOTAL SECTION 73 COSTS:	\$5,100
TOTAL ESTIMATED COST:	\$186,820

13 ASSESSMENTS

The Drainage Act requires that the total estimated cost be assessed to the affected lands and roads under the categories of Benefit (Section 22), Outlet Liability (Section 23), Injuring Liability (Section 23), Special Benefit (Section 24) and Increased Cost (Section 26). On this project assessment for Benefit, Special Benefit, Outlet Liability and Increased Cost (Special) Assessment are involved.

13.1 Calculation of Assessments

Appendix A in this report shows the method of calculating the assessments for the Drain. Appendix A divides the Drain into intervals. The estimated cost for each interval is then determined. For each interval, the first step in the assessment calculation is to determine the benefit assessment to the affected lands and roads, then special assessments to roads and utilities are determined, where applicable. After deducting the total benefit and special assessments from the interval cost, the balance of the cost is then assessed as outlet liability on a per hectare basis to all lands and roads in the watershed.

13.2 Benefit Assessments (Section 22 and 24)

Section 22 benefits were determined based on the estimated value provided to the property by the works and are not proportional to the watershed area.

Section 24 special benefit is assessed to lands where additional work or features are requested that are not necessary for the function of the Drain. Special benefit examples include hauling spoil offsite, aesthetic features and installing lateral drains. Non-grantable benefits relate to work that is not eligible for Grant according to the current OMAFRA policy. Non-proratable benefits are not used to determine the actual cost factor for the final cost levy. Some examples would be lateral drains, culverts or hauling of spoil. Columns with non-grantable and non-proratable are used to complete the final assessment. Table 13.2-1 - Benefit Assessments provides a summary of the benefit assessments.

Table 13.2-1 - Benefit Assessments

Roll Number (Owner)	Location	Section 22	Section 24	Total Benefit	Non-grantable	Non-proratable
00-2113-000	Interval 1	5,600		5,600		
00-2115-000	Interval 1	48,400		48,400		
00-2116-000	Interval 1	32,900		32,900		
00-2115-000	Interval 2	14,300		15,200		
00-2116-000	Interval 2	4,300		4,300		
TOTAL BENEFITS		105,500		105,500		

13.3 Outlet Liability Assessments (Section 23)

Section 23(3) of the Drainage Act states that outlet liability assessment is to be based on the volume and rate of flow of the water artificially caused to flow. Therefore the lands and roads in the watershed are assessed on a per hectare basis, with adjustments made to recognize the different amount of runoff generated by different land uses. The basis for the adjustments is 1 hectare of cleared agricultural land contributing both surface and subsurface water to the Drain. Land uses with a different runoff rate are adjusted by the factors given in Table 13.3-1 - Runoff Factors Table.

Table 13.3-1 - Runoff Factors Table

Land Use	Runoff factor
Agricultural	1
Forest and Tiled into Drain	0.5
Gravel Road	2
Paved Road	3

13.4 Assessment Schedules

13.4.1 Schedule A- Schedule of Assessments

The estimated cost for the drainage works in this report is distributed among lands, roads and utilities, as shown in Schedule A, the Schedule of Assessments. In Schedule A each parcel of land assessed has been identified by the municipal assessment roll number at the time of the preparation of this report. The size of each parcel was established using the assessment roll information. If an "F" is shown in the first column, it denotes lands with current Farm Property Tax Class designation that may qualify for Grant. For convenience only, each parcel is also identified by the owner name(s) from the last revised assessment roll.

13.4.2 Schedule B - Schedule of Assessments for Maintenance

In accordance with Section 74 of the Act, the Drain shall be maintained by the Municipality, and the cost of maintenance shall be assessed to lands and roads upstream of the maintenance location, pro rata with the amounts in Schedule B. The amounts in Schedule B are derived from the cost distribution shown in Appendix A, and will not be levied with the final cost of the drainage works.

Roll numbers are per the Municipality's last revised assessment roll, names included for convenience. Amounts are not payable at this time; they determine the share of future maintenance costs. The Municipality will confirm eligibility for the grant at the time the maintenance cost is levied.

Schedule B is divided into columns to reflect the different drain intervals where maintenance work may be undertaken. These column intervals assist in identifying upstream lands and roads to be assessed for future maintenance. The percentages shown in Schedule B determine the share of future maintenance to be levied to property or road. For example, a \$1,000 beaver dam removal or tile repair will result in a \$50 assessment to a property with a 5% maintenance assessment.

13.4.3 Schedule C – Schedule for Actual Cost By-law

After the construction of the Drain is certified, complete by the Engineer, the Municipality will determine the actual cost of the Drain. Actual assessments will be determined by prorating the actual cost of the Drain using Schedule C. Schedule C illustrates the estimated net assessments after deducting allowances and grants from the total assessments shown in Schedule A. Eligibility for the grant will be confirmed by the Municipality at the time the actual cost is levied. Actual assessments in Schedule C will be levied to the owner of the identified parcel at the time the Actual Cost By-law is passed. Roll numbers are per the Municipality's last revised assessment roll, and the names are included for convenience.

14 GRANT

In accordance with the provisions of Section 85 of the Act, a grant not exceeding 1/3 (33-1/3%) may be available on the assessments against lands used for agricultural purposes. The current OMAFRA grant policy defines agricultural lands as privately owned parcels of land which have the Farm Property Class Tax Rate. Based on Municipal assessment roll information, parcels that have the Farm Property Tax Class are identified with an 'F' in the first column of the assessment schedules.

Section 88 of the Act provides for the Municipality to apply for this grant after the construction of the Drain is certified complete by the Engineer. The Municipality must confirm the Farm Property Tax Class on the assessed parcels at the time the

grant application is completed and submitted to OMAFRA. OMAFRA has the authority to determine grant eligibility regardless of the designation herein.

If any portion of the drainage works is not eligible for the grant, those ineligible costs have been separately identified in this report.

15 PRIVACY OF LANDS

Although a municipal drain is situated on the property of various landowners, one landowner may not enter another landowner's property via the Drain. Persons authorized to enter private lands to carry out duties authorized under the Act include Engineers (or their assistants), Contractors (or their assistants) and the appointed Drainage Superintendents (or their assistants).

16 MAINTENANCE

16.1 General

Section 74 of the Act requires the Drain, as outlined in this report, to be maintained by the Municipality, and the cost of maintenance to be assessed to the upstream lands and roads pro rata with the assessments in Schedule B.

All debris and dam removal on the Dickies Creek shall only be assessed as per Interval 1 in the Schedule B and No assessment shall be make to upstream of Dickies Creek.

The 1929 Gaunt-Laidlaw Drain is to be abandon in it's entirety.

All parties affected by the Drain, are encouraged to periodically inspect the Drain and report any visible or suspected problems to the Municipality.

A right-of-way along the Drain and access routes to the Drain exist for the Municipality to maintain the Drain. The right-of-way for the Drain, as described in the Allowances section of this report shall remain free of obstructions. The cost of removing obstructions is the responsibility of the owner.

Any landowner making a new connection to the Drain shall notify the Drainage Superintendent before making the connection. If the Drainage Superintendent is not notified, the cost to remedy new connections that obstruct or otherwise damage the Drain will be the responsibility of the owner.

The discharge of anything but clean, unpolluted water into a drain is regulated by other provincial legislation. Any non-compliance will be reported to the appropriate environmental agency.

Buffer strips along open drains shall be maintained in accordance with the specifications in this report.

16.2 Updating Future Maintenance Schedules

To ensure future maintenance assessments are equitable, the assessments provided in this report should be reapportioned under Section 65 when severances or amalgamations occur when new lands are connected to the Drain or when a land-use change occurs that can be accommodated by the existing Drain. If a future land-use change will cause the drain capacity to be exceeded, a report under Section 4 or 78 may be required to provide increased capacity.

17 BY-LAW

This report including the drawings and specifications, assessment schedules and appendices, when adopted by by-law in accordance with the Act, provides the basis for construction and maintenance of the Drain.

All of which is respectfully submitted,

K. SMART ASSOCIATES LTD.



N. Morris, P. Eng.

mw



**SCHEDULE A - SCHEDULE OF ASSESSMENTS FOR CONSTRUCTION
GAUNT-LAIDLAW MUNICIPAL DRAIN
TOWNSHIP OF HURON KINLOSS**

Con	Lot	Roll Number & Owner	Main Drain				Total	Gross Total Assessment (\$)	
			Total ha affected	Benefit (Sec. 22)	Special (Sec. 26)	Outlet (Sec. 23)			
<i>Twp of Huron Kinloss (Roll No. 41-07-110)</i>									
F	2	26	MARTIN ELVIN 00-2113-000	0.0	5,600	0	0	5,600	5,600
F	2	27	MARTIN HARVEY 00-2115-000	19.9	62,700	0	23,472	86,172	86,172
F	2	28	METSKE MICHAEL 00-2116-000	40.6	37,200	0	54,125	91,325	91,325
Subtotal (Lands):				60.5	105,500	0	77,597	183,097	183,097
South Kinloss Ave				0.1	0	0	3,723	3,723	3,723
Subtotal (Roads & Utilities):				0.1	0	0	3,723	3,723	3,723
TOTAL ASSESSMENT GAUNT-LAIDLAW DRAIN:				60.6	105,500	0	81,320	186,820	186,820

Notes:

- Lands noted with an "F" are classified as agricultural and according to current OMAFRA policy qualify for the 1/3 grant. Eligibility for the 1/3 grant will be confirmed at the time the final cost is levied.
- Section 21 of the Drainage Act, RSO 1990 requires that assessments be shown opposite each parcel of land and road affected. The affected parcels of land have been identified using the roll number from the last revised assessment roll for the Township. For convenience the owner's names as shown by the last revised assessment roll have also been included.

**SCHEDULE B - SCHEDULE OF ASSESSMENTS FOR FUTURE MAINTENANCE
GAUNT-LAIDLAW MUNICIPAL DRAIN
TOWNSHIP OF HURON KINLOSS**

Con	Lot	Roll No. & Owner	DICKIES CREEK		Open Ditch		Tile						Overflow Swale					
			Interval 1 1+288 to 0+545		Interval 2 0+545 to 0+263		Interval 3 0+263 to 0+130		Interval 4 0+130 to 0+000		Interval 7 0+000 to -0+169		Interval 5 0+263 to 0+130		Interval 6 0+130 to 0+000		Interval 8 0+000 to -0+241	
			\$	%	\$	%	\$	%	\$	%	\$	%	\$	%	\$	%	\$	%
Twp of Huron Kinloss (Roll No. 41-07-110)																		
2	26	MARTIN ELVIN 00-2113-000	0	0.00	100	1.79	0	0.00	0	0.00	0	0.00	0	0.00	0	0.00	0	0.00
2	27	MARTIN HARVEY 00-2115-000	2,570	34.73	3,020	53.92	2,497	47.11	1,838	35.35	1,503	44.21	507	39.00	344	26.46	635	26.46
2	28	METSKE MICHAEL 00-2116-000	4,727	63.88	2,427	43.34	2,743	51.76	3,329	64.02	1,539	45.26	779	59.92	948	72.92	1,734	72.25
Total Assessments on Lands:			7,297	98.61	5,547	99.05	5,240	98.87	5,167	99.37	3,042	89.47	1,286	98.92	1,292	99.38	2,369	98.71
South Kinloss Ave			103	1.39	53	0.95	60	1.13	33	0.63	358	10.53	14	1.08	8	0.62	31	1.29
Total Assessments on Roads:			103	1.39	53	0.95	60	1.13	33	0.63	358	10.53	14	1.08	8	0.62	31	1.29
TOTAL ASSESSMENTS GAUNT-LAIDLAW DRAIN:			7,400	100.00	5,600	100.00	5,300	100.00	5,200	100.00	3,400	100.00	1,300	100.00	1,300	100.00	2,400	100.00

Notes:

1. Agricultural designation not included as grant eligibility has to be confirmed at the time of maintenance cost levy.
2. \$ amounts above are listed solely for calculating percentages (share of future maintenance costs) and will not be levied with the final cost of the drainage works.

**SCHEDULE C - SCHEDULE FOR ACTUAL COST BYLAW
GAUNT-LAIDLAW MUNICIPAL DRAIN
TOWNSHIP OF HURON KINLOSS**

Con	Lot	Owner	Ha. Affected	Gross Assessment	1/3 Grant	Allowances	NET	
<i>Twp of Huron Kinloss (Roll No. 41-07-110)</i>								
F	2	26	MARTIN ELVIN 00-2113-000	0.0	5,600	1,867	3,500	233
F	2	27	MARTIN HARVEY 00-2115-000	19.9	86,172	28,724	4,700	52,748
F	2	28	METSKE MICHAEL 00-2116-000	40.6	91,325	30,442	1,750	59,133
Subtotal (Lands):				60.5	183,097	61,033	9,950	112,114
South Kinloss Ave				0.1	3,723	0	0	3,723
Subtotal (Roads & Utilities):				0.1	3,723	0	0	-
TOTAL ASSESSMENT GAUNT-LAIDLAW DRAIN:				60.6	186,820	61,033	9,950	112,114

Notes:

1. Lands noted with an "F" are classified as agricultural and according to current OMAFRA policy qualify for the 1/3 grant. Eligibility for the 1/3 grant will be confirmed at the time the final cost is levied.
2. Actual assessment is levied to the owner of the parcel at the time the final cost is levied.

**APPENDIX A - CALCULATION OF ASSESSMENTS
GAUNT-LAIDLAW MUNICIPAL DRAIN
TOWNSHIP OF HURON KINLOSS**

	Main Drain													
			Interval 1				Interval 2				Grand Total			
			Station	1+288	to	0+000	Station	0+000	to	-0+169				
ESTIMATED COST	Allowances		8,450				1,500				9,950			
	Construction		85,000				18,700				103,700			
	Engineering		42,500				7,000				49,500			
	Construction Supervision		12,800				2,800				15,600			
	Administration		4,200				900				5,100			
	Net HST		2,470				500				2,970			
TOTAL		155,420				31,400				186,820				
Roll No. (Owner)	Total Ha Affected	Total ha Adjusted	Benefit (Sec. 22)	Special (Sec. 26)	Adj Ha	Outlet (Sec. 23)	Benefit (Sec. 22)	Special (Sec. 26)	Adj Ha	Outlet (Sec. 23)	Total Benefits	Total Special	Total Outlets	TOTAL
<i>Twp of Huron Kinloss (Roll No. 41-07-110)</i>														
MARTIN ELVIN 00-2113-000	0.0	0.0	5,600		0.0	0	0		0.0	0	5,600	0	0	5,600
MARTIN HARVEY 00-2115-000	19.9	20.3	48,400		15.9	20,440	14,300		0.9	3,032	62,700	0	23,472	86,172
METSKE MICHAEL 00-2116-000	40.6	36.6	32,900		36.6	47,051	4,300		2.1	7,074	37,200	0	54,125	91,325
Subtotal (Lands):	60.5	56.9	86,900	0	52.5	67,491	18,600	0	3.0	10,106	105,500	0	77,597	183,097
South Kinloss Ave	0.1	0.8			0.8	1,029			0.8	2,694	0		3,723	3,723
Subtotal (Roads & Utilities):	0.1	0.8	0	0	0.8	1,029	0	0	0.8	2,694	0	0	3,723	3,723
TOTAL ASSESSMENT GAUNT-LAIDLAW DRAIN:	60.6	57.7	86,900	0	53.3	68,520	18,600	0	3.8	12,800	105,500	0	81,320	186,820

**APPENDIX B - CALCULATION OF ASSESSMENTS FOR FUTURE MAINTENANCE
GAUNT-LAIDLAW MUNICIPAL DRAIN
TOWNSHIP OF HURON KINLOSS**

Roll No. (Owner)	Total Ha Affected	Total ha Adjusted	DICKIES CREEK				Open Ditch				Tile																		
			Interval 1				Interval 2				Interval 3				Interval 4				Interval 7										
			Station	1+288	to	0+545	Station	0+545	to	0+263	Station	0+263	to	0+130	Station	0+130	to	0+000	Station	0+000	to	-0+169							
open ditch			7,400			open ditch			5,600			Tile			5,300			Tile			5,200			Tile			3,400		
			Benefit (Sec. 22)	Adj Ha	Outlet (Sec. 23)	%	Benefit (Sec. 22)	Adj Ha	Outlet (Sec. 23)	%	Benefit (Sec. 22)	Adj Ha	Outlet (Sec. 23)	%	Benefit (Sec. 22)	Adj Ha	Outlet (Sec. 23)	%	Benefit (Sec. 22)	Adj Ha	Outlet (Sec. 23)	%							
Twp of Huron Kinloss (Roll No. 41-07-110)																													
MARTIN ELVIN 00-2113-000	0.0	0.0		0.0	0	0.00	100	0.0	0	1.79		0.0	0	0.00		0.0	0	0.00		0.0	0	0.00							
MARTIN HARVEY 00-2115-000	19.9	20.3		19.9	2,570	34.73	1,700	19.9	1,320	53.92	2,100	5.3	397	47.11	1,800	0.9	38	35.35	1,100	0.9	403	44.21							
METSKE MICHAEL 00-2116-000	40.6	36.6		36.6	4,727	63.88		36.6	2,427	43.34		36.6	2,743	51.76	1,800	36.6	1,529	64.02	600	2.1	939	45.26							
Subtotal (Lands):	60.5	56.9	0	56.5	7,297	98.61	1,800	56.5	3,747	99.05	2,100	41.9	3,140	98.87	3,600	37.5	1,567	99.37	1,700	3.0	1,342	89.47							
South Kinloss Ave	0.1			0.8	103	1.39		0.8	53	0.95		0.8	60	1.13		0.8	33	0.63		0.8	358	10.53							
Subtotal (Roads & Utilities):	0.1	0.0	0	0.8	103	1.39	0	0.8	53	0.95	0	0.8	60	1.13	0	0.8	33	0.63	0	0.8	358	10.53							
TOTAL ASSESSMENT GAUNT-LAIDLAW DRAIN:	60.6	56.9	0	57.3	7,400	100.00	1,800	57.3	3,800	100.00	2,100	42.7	3,200	100.00	3,600	38.3	1,600	100.00	1,700	3.8	1,700	100.00							

**APPENDIX B - CALCULATION OF ASSESSMENTS FOR FUTURE MAINTENANCE
GAUNT-LAIDLAW MUNICIPAL DRAIN
TOWNSHIP OF HURON KINLOSS**

Roll No. (Owner)	Overflow Swale												Grand Total			
	Interval 5				Interval 6				Interval 8				Total Benefits	Total Outlets	TOTAL	%
	Station	0+263	to	0+130	Station	0+130	to	0+000	Station	0+000	to	-0+241				
	open ditch 1,300				open ditch 1,300				open ditch 2,400				31,900			
	Benefit (Sec. 22)	Adj Ha	Outlet (Sec. 23)	%	Benefit (Sec. 22)	Adj Ha	Outlet (Sec. 23)	%	Benefit (Sec. 22)	Adj Ha	Outlet (Sec. 23)	%				
Twp of Huron Kinloss (Roll No. 41-07-110)																
MARTIN ELVIN 00-2113-000		0.0	0	0.00		0.0	0	0.00		0.0	0	0.00	100	0	100	0.31
MARTIN HARVEY 00-2115-000	400	6.4	107	39.00	300	4.4	44	26.46	600	0.9	35	26.46	8,000	4,914	12,914	40.48
METSKE MICHAEL 00-2116-000	200	34.6	579	59.92	600	34.6	348	72.92	1,100	16.4	634	72.25	4,300	13,926	18,226	57.13
Subtotal (Lands):	600	41.0	686	98.92	900	39.0	392	99.38	1,700	17.3	669	98.71	12,400	18,840	31,240	97.92
South Kinloss Ave		0.8	14	1.08		0.8	8	0.62		0.8	31	1.29	0	660	660	2.08
Subtotal (Roads & Utilities):	0	0.8	14	1.08	0	0.8	8	0.62	0	0.8	31	1.29	0	660	660	2.08
TOTAL ASSESSMENT GAUNT-LAIDLAW DRAIN:	600	41.8	700	100.00	900	39.8	400	100.00	1,700	18.1	700	100.00	12,400	19,500	31,900	100.00

GENERAL CONDITIONS**TABLE OF CONTENTS**

200.1	SCOPE	1
200.2	ORDER OF PRECEDENCE	1
200.3	MUNICIPALITY	1
200.4	TENDERS	1
200.5	EXAMINATION OF SITE, PLANS AND SPECIFICATIONS	1
200.6	COMMENCEMENT AND COMPLETION OF WORK	2
200.7	NOTICES RE COMMENCEMENT OF WORK	2
200.8	PERMITS, NOTICES, LAWS AND RULES	2
200.9	HEALTH AND SAFETY	2
200.10	LIMITATIONS OF OPERATIONS	2
200.11	SUPERVISION	2
200.12	CHARACTER AND EMPLOYMENT OF WORKERS	3
200.13	SUB-CONTRACTORS	3
200.14	PAYMENT	3
200.15	TERMINATION OF CONTRACT BY THE MUNICIPALITY	3
200.16	LIQUIDATED DAMAGES	4
200.17	CONTRACTOR'S LIABILITY	4
200.18	LIABILITY INSURANCE	5
200.19	LOSSES DUE TO ACTS OF NATURE, ETC.	5

200 GENERAL CONDITIONS**200.1 SCOPE**

The work to be done under this contract consists of supplying all labour, equipment and materials to construct the drainage work as outlined in the Instructions to Tenderers, the Form of Tender and Agreement, the Schedule of Tender Prices, the Drawings, the General Conditions, Special Provisions and the Standard Specifications.

200.2 ORDER OF PRECEDENCE

In case of any inconsistency or conflict between the drawings and specifications, the following order of precedence shall apply: Addenda, Form of Tender and Agreement, Schedule of Tender Prices, Special Provisions, Contract Drawings, Standard Specifications, General Conditions.

200.3 MUNICIPALITY

Municipality refers to a municipal corporation in the Province of Ontario. Where reference to Township, County, Region, Town, City or Owner appears it shall be deemed to be the same as the word Municipality. Where reference to owner appears in the specifications it is usually in reference to the owner of the property on which the drain is being constructed.

200.4 TENDERS

Tenders are to be submitted on a lump sum basis for the complete works or a portion thereof, as instructed by the Municipality. The Schedule of Tender Prices must be completed and submitted with the Form of Tender and Agreement even though the Contract will be a lump sum. As outlined in the Instructions to Tenders a deposit in the form of a certified cheque, bank draft, bonding or irrevocable letter of credit must accompany each tender as a guarantee of good faith. The deposit shall name the Municipality as the payee. All deposits, except that of the Tenderer to whom the work is awarded, will be returned within 10 days of the time the contract is awarded. The certified cheque of the Tenderer awarded the work will be retained as Contract Security and returned with the Completion Certificate for the work. A Performance Bond may also be required to ensure maintenance of the work for a period of one year after the date of the Completion Certificate.

200.5 EXAMINATION OF SITE, PLANS AND SPECIFICATIONS

Prior to the submission of the Tender, the Tenderer must examine the premises and site to compare them with the Drawings and Specifications in order to be satisfied with the existing conditions and the extent of the work to be done. The Tenderer must ensure that the meaning and intent of the drawings, estimated quantities and specifications is clearly understood before submission of the Tender. No allowances shall be made on behalf of the Contractor by reason of any error made in the preparation of the tender submission.

Any estimates of quantities shown or indicated on the drawings or elsewhere in the tender document are provided for the convenience of the Tenderer. The Tenderer should check the estimate of quantities for accuracy. Any use made of the estimated quantities by the Tenderer in calculating the tendered amounts is done at the Tenderers risk.

200.6 COMMENCEMENT AND COMPLETION OF WORK

The work must commence immediately after the Tenderer is notified of the contract award or at a later date, if set out as a condition in the Form of Tender and Agreement. If weather and ground conditions are unsuitable, work may be started at a later date from either of the above two dates if such delay is approved by the Engineer. The Contractor shall provide a minimum of 48 hours advance notice to the Engineer and the Municipality before commencement of any work. The work must proceed in such manner as to ensure its completion at the earliest possible date consistent with first class workmanship and within the time limit set out in the tender/contract document. Failure to commence or complete the work as set out in the tender/contract document may result in a forfeiture of all or part of the Contract Security if the Engineer deems that damages have been sustained to the Municipality or to any landowner because of the non-commencement or non-completion of the contract as awarded and that the failure to meet the specified dates has been the fault of the Contractor.

200.7 NOTICES RE COMMENCEMENT OF WORK

If the Contractor leaves the job site for a period of time after initiation of work, a minimum of 48 hours advance notice shall be given to the Engineer and the Municipality before commencement of any further work. If any work is commenced without the advance notice the Contractor shall be fully responsible for all such work undertaken prior to such notification and shall make good any works or materials judged to be inadequate or constructed in any manner that may have been subject to alteration if made known to the Engineer prior to commencement of construction.

200.8 PERMITS, NOTICES, LAWS AND RULES

The Contractor shall apply and pay for all necessary permits or licenses required for the execution of the work. This shall not include the obtaining of permanent easements or rights or servitude. The Contractor shall give all necessary notices and pay all fees required by the law and comply with all laws, ordinances, rules and regulations relating to the work and to the preservation of the public's health and safety and if the specifications and drawings are at variance therewith, any resulting additional expense incurred by the Contractor shall constitute an addition to the contract price.

200.9 HEALTH AND SAFETY

Contractor must comply with the Occupational Health and Safety Act (OHSA) and the associated Regulations for Construction Projects. Contractor will also follow any site-specific safety and training requirements of the Municipality, agencies, utility companies or other authorities.

Communication about site-specific hazards and safety requirements shall occur at the pre-construction meeting. If no pre-construction meeting is conducted, Contractor will communicate site-specific hazards and safety requirements before beginning work.

Contractor shall immediately report any workplace incidents, near misses, injuries and occupational illnesses to the Engineer.

200.10 LIMITATIONS OF OPERATIONS

Except for such work as may be required by the Engineer to maintain the works in a safe and satisfactory condition, the Contractor shall not carry out operations under the contract on Sundays or Statutory Holidays without permission in writing from the Engineer. The Engineer may direct in writing to the Contractor to cease or limit operations under the contract on any day or days if the operations are of such a nature, or if the work is so located, or if the traffic is of such a volume, that the Engineer deems it necessary or expedient to do so.

200.11 SUPERVISION

The Contractor shall provide constant supervision of the construction work and shall keep a competent foreman in charge at the site.

200.12 CHARACTER AND EMPLOYMENT OF WORKERS

The Contractor shall employ only orderly, competent and skillful workers to do the work and shall give preference to available qualified residents in the area of the contract. Whenever the Engineer informs the Contractor in writing that any workers are, in the opinion of the Engineer, disorderly, incompetent, or breaking the law, such workers shall be discharged from the job site and shall not again be employed on the job site without the written consent of the Engineer.

200.13 SUB-CONTRACTORS

If the Municipality so directs, the Contractor shall not sublet the whole or any part of this contract without the approval of the Engineer.

200.14 PAYMENT

Progress payments in cash equal to about 90% of the value of the work done and materials incorporated in the work will be made to the Contractor monthly. If directed by the Engineer the Contractor may be required to provide a written request for the progress payment amount. An additional 7% will be paid 45 days after the date of the Completion Certificate by the Engineer and 3% of the contract price may be reserved by the Municipality as a maintenance holdback for one year from the date of the Completion Certificate.

The holdbacks noted above may be increased by the Municipality if, in the written opinion of the Engineer, particular conditions of the contract require such greater holdback.

After the completion of the work any part of maintenance holdback may be used to correct defects from faulty construction and/or materials provided that notice shall first be given by the Engineer in writing to the Contractor stating that the Contractor has seven (7) days in which to remedy the defect in construction and/or materials.

200.15 TERMINATION OF CONTRACT BY THE MUNICIPALITY

Termination of the contract by the Municipality may be considered if the Contractor:

1. should be adjudged bankrupt or make a general assignment for the benefit of creditors or if a receiver should be appointed on account of insolvency;
2. should refuse or fail to supply enough properly skilled workmen or proper materials after having received seven (7) days' notice in writing from the Engineer to supply such additional workmen or materials in order to commence or complete the works;
3. should fail to make prompt payment to sub-contractors or for materials or labour;
4. should persistently disregard laws, ordinances, or instructions from the Engineer, or otherwise be guilty of a substantial violation of the provisions of the contract;

then the Municipality, upon Certificate of the Engineer that sufficient cause exists to justify such action, may without prejudice to any other right or remedy, give written notice to the Contractor to terminate the employment of the Contractor and take possession of the premises, and of all materials, tools and appliances thereon, and may finish the work by whatever method the Municipality may deem expedient, but without undue delay or expense. In such case, the Contractor shall not be entitled to receive any further payment until the work is finished. If the unpaid balance of the contract price will exceed the expense of finishing the work including compensation to the Engineer for additional services and including other damages of every name and nature, such excess shall be paid to the

Contractor. If such expense will exceed such unpaid balance including the Contract Security, the Contractor shall pay the difference to the Municipality. The expense incurred by the Municipality, as herein provided, shall be certified by the Engineer. If the contract is terminated by the Municipality due to the Contractor's failure to properly commence the works, the Contractor shall forfeit the Contract Security and furthermore shall pay to the Municipality an amount to cover the increased costs, if any, associated with a new tender for the contract being terminated.

If any unpaid balance and the Contract Security do not equal the monies owed by the Contractor upon the termination of the contract, the Municipality may also charge such expenses against any money which is or may thereafter be due to the Contractor from the Municipality.

200.16 LIQUIDATED DAMAGES

It is agreed by the parties to the Contract that in case all the work called for under the Contract is not finished or complete within the period of time as set forth in the Tender/Contract Document, damage will be sustained by the Municipality. It is understood by the parties that it will be impracticable and extremely difficult to ascertain and determine the actual damage which the Municipality will sustain in the event of and by reason of such delay. The parties hereto agree that the Contractor will pay to the Municipality a sum as set out in the Form of Tender and Agreement for liquidated damages for each and every calendar day delay, including Saturdays, Sundays and Statutory Holidays, in finishing the work in excess of the number of working days prescribed. It is agreed that the liquidated damages amount is an estimate of the actual damage to the Municipality which will accrue during the period in excess of the prescribed number of working days.

The Municipality may deduct any amount due under this section from any monies that may be due or payable to the Contractor on any account whatsoever. The liquidated damages payable under this section are in addition to and without prejudice to any other remedy, action or other alternative that may be available to the Municipality.

The Contractor shall not be assessed with liquidated damages for any delay caused by acts of nature, or of the Public Enemy, Acts of the Province or of any Foreign State, Fire, Flood, Epidemics, Quarantine Restrictions, Embargoes or any delays of Sub-Contractors due to such causes.

If the time available for the completion of the work is increased or decreased by reason of alterations or changes made under the provisions of the Contract, the number of working days shall be increased or decreased as determined by the Engineer.

If the Form of Tender and Agreement does not show an amount for Liquidated Damages then Liquidated Damages do not apply for this contract.

200.17 CONTRACTOR'S LIABILITY

The Contractor and all workers, agents or any party under the Contractor's control, including Sub-Contractors, shall use due care that no person or property is injured and that no rights are infringed during the construction work outlined in the contract. The Contractor shall be solely responsible for all damages by whomsoever claimable in respect of any injury to persons or to lands, buildings, structures, fences, livestock, trees, crops, roadways, ditches, drains and watercourses, whether natural or artificial, or property of whatever description and in respect of any infringement of any right, privilege or easement wherever occasioned in the carrying on of the work or any part thereof, or by any neglect, misfeasance or non-feasance on the Contractor's part or on the part of any workers, agents or parties under the Contractor's control including Sub-Contractors, and shall bear the full cost thereof. The Contractor shall be fully responsible to make such temporary provisions as may be necessary to ensure the avoidance of any such damage, injury or infringement and to prevent the interruption of or danger or menace to the traffic in any railway or any public or private road entrance or sidewalk and to secure to all persons and corporations the uninterrupted enjoyment of all their rights, in and during the performance of the work. The Contractor shall indemnify and save harmless

the Municipality and the Engineer from and against all claims, demands, losses, costs, damages, actions, suits or other proceedings by whomsoever made, brought or prosecuted in any manner based upon, occasioned by, or attributed to any such damage, injury or infringement.

Wherever any work is of such an extent and nature that it must necessarily be confined to particular areas of a roadway, a working area, or private property, the Contractor shall use reasonable care not to damage or deface the remaining portions of the property, and if any damage is occasioned as a result of the Contractor's operations, it shall be rectified by and at the expense of the Contractor, to the satisfaction of the Engineer. Notwithstanding the indemnity provisions contained in this section, where in the opinion of the Engineer the Contractor has failed to rectify any damage, injury or infringement or has failed to adequately compensate any person for any damage, injury or infringement for which the Contractor is responsible under the contract, the Engineer, following notice in writing to the Contractor of an intention so to do, may withhold payment of any monies due the Contractor under this or any other contract until the Contractor has rectified such damage, injury or infringement or has paid adequate compensation for such damage, injury or infringement, provided however, that the Municipality will not withhold such monies where in the opinion of the Engineer there are reasonable grounds upon which the Contractor denies liability for such damage, injury or infringement and the Contractor has given the claimant a reasonable time in which to establish the validity of the claim, and provided further that the amount withheld under this section shall not exceed the amount of such claims against the Contractor.

Where the Contractor uses privately owned lands for pits or waste disposal areas, the Contractor shall comply with applicable laws and provide the Engineer with a release signed by or on behalf of the owner of each pit or waste disposal area used by the Contractor. If the said release is not obtained, then sufficient monies will be withheld from the Contractor except, however, where the owner's signature is withheld solely on the basis of damage, injury, or infringement it will be dealt with as provided elsewhere in this subsection.

Nothing herein contained shall be construed as in any way restricting or limiting the liability of the Contractor under the laws of the country, province or locality in which the work is being done. Neither the Completion Certificate nor final payment thereunder, nor any provision in the Contract Document shall relieve the Contractor from this liability.

200.18 LIABILITY INSURANCE

The Contractor shall take out and keep in force until the date of acceptance of the entire work by the Engineer, a comprehensive policy of public liability and property damage insurance providing insurance coverage of at least \$3,000,000 for each and every accident, exclusive of interest and cost, against loss or damage resulting from bodily injury to or death of one or more persons and loss of or damage to property and such policy shall where, and as requested by the Municipality, name the Municipality and the Engineer as an additional insured thereunder and shall protect the Municipality against all claims for all damage or injury including death to any person or persons and for damage to any property of the Municipality or any other public or private property resulting from or arising out of any act or omission on part of the Contractor or any of his servants or agents during the execution of the Contract.

200.19 LOSSES DUE TO ACTS OF NATURE, ETC.

All damage, loss, expense and delay incurred or experienced by the Contractor in the prosecution of the work, by reason of unanticipated difficulties, bad weather, strikes, wars, acts of nature, or other mischances, shall be borne by the Contractor and shall not be the subject of a claim for additional compensation.

TABLE OF CONTENTS

400.1	ABBREVIATIONS.....	1
400.2	PRE CONSTRUCTION MEETING	1
400.3	COLD WEATHER.....	1
400.4	WORKING AREA	1
400.5	ACCESS.....	1
400.6	ACCESS TO PROPERTIES ADJOINING THE WORK	2
400.7	DRAINAGE SUPERINTENDENT	2
400.8	ALTERATIONS TO WORK.....	2
400.9	ERRORS AND UNUSUAL CONDITIONS	2
400.10	TESTS	2
400.11	BENCHMARKS AND STAKES.....	3
400.12	OPENING UP OF FINISHED WORK	3
400.13	FINAL INSPECTION.....	3
400.14	WARRANTY	3
400.15	MATERIALS	4
400.16	RIPRAP	5
400.17	GEOTEXTILE	5
400.18	DISPOSAL OF MATERIALS	5
400.19	NOTIFICATION OF RAILROADS, ROAD AUTHORITIES AND UTILITIES	5
400.20	WORKING IN ROAD ALLOWANCES	6
400.21	LOCATIONS OF EXISTING UTILITIES.....	6
400.22	LANEWAYS.....	7
400.23	EXISTING CROSSING CLEANOUT	7
400.24	FENCES	7
400.25	LIVESTOCK	8
400.26	STANDING CROPS	8
400.27	CLEARING VEGETATION	8
400.28	ROCK REMOVAL.....	9
400.29	SEEDING	10
400.30	EROSION CONTROL BLANKETS.....	11
400.31	SEDIMENT CONTROL.....	11
400.32	GRASSED WATERWAYS AND OVERFLOW SWALES.....	12
400.33	BUFFER STRIPS	13
400.34	MAINTENANCE CORRIDOR.....	13
400.35	POLLUTION	13
400.36	SPECIES AT RISK	13

400 STANDARD SPECIFICATIONS FOR CONSTRUCTION OF DRAINS**400.1 ABBREVIATIONS**

- i) MTO means the Ministry of Transportation of Ontario.
- ii) ASTM means the American Society for Testing Materials.
- iii) CSA means the Canadian Standard Association.
- iv) OPSD means Ontario Provincial Standard Drawings
- v) OPSS means Ontario Provincial Standard Specifications
- vi) DFO means Fisheries and Oceans Canada
- vii) MNRF means Ministry of Natural Resources and Forestry
- viii) MECP means Ministry of Environment, Conservation and Parks

400.2 PRE CONSTRUCTION MEETING

The Contractor should arrange a pre-construction meeting with the Engineer, Municipality, affected landowners prior to commencement of construction.

If there is no pre-construction meeting or if a landowner is not present at the pre-construction meeting, the following shall apply. The drain is to be walked by the Contractor and each landowner prior to construction to ensure that both agree on the work to be done. Any difference of opinion shall be referred to the Engineer for decision. If the landowner is not contacted for such review, they are to advise the Engineer and/or Municipality.

400.3 COLD WEATHER

When working in cold weather is approved by the Engineer, the Contractor shall provide suitable means for heating, protection, and snow and ice removal. All work completed in cold weather conditions shall be to the satisfaction of the Engineer and any additional cost to remedy unsatisfactory work, or protect the work shall be borne by the Contractor. All backfilling operations shall be done as soon as possible to avoid backfilling with ground containing frozen particles. The Contractor will assume all responsibility for damages to any tile drains and for settlements or bank slippages that may result from work in cold weather.

400.4 WORKING AREA

Where any part of the drain is on a road allowance, the road allowance shall be the working area. For a closed drain the working area shall be a 10 metre width on either side of the trench or any combination not exceeding 20 metres. A 10m x 10m working area shall exist around any catchbasin, junction box or access point. For an open drain the working area shall be 17 metres on the side for leveling and 3 metres on the opposite side. A 10m working area shall exist for any overflow swale or grassed waterway. If any part of the drain is close to a property line then the fence line shall be one of the limits of the work area. Reduced or increased working areas will be described in detail on the Drawings.

400.5 ACCESS

The Contractor shall have access to the drain by entering the working area directly from road allowances or along access routes shown on the Drawings. All specifications governing fences, livestock and crops during drain construction apply to access routes. No other access routes shall be used unless first approved by the Engineer and the affected landowner. The Contractor shall contact each landowner prior to using the designated access routes. Contractor shall make good any damages caused by using the designated access routes.

400.6 ACCESS TO PROPERTIES ADJOINING THE WORK

The Contractor shall provide at all times and at no additional cost, adequate pedestrian access to private homes and commercial establishments unless otherwise authorized by the Engineer. Where interruptions to access have been authorized by the Engineer, reasonable notice shall be given by the Contractor to the affected landowners and such interruptions shall be arranged to minimize interference to those affected.

400.7 DRAINAGE SUPERINTENDENT

Where a Drainage Superintendent (Superintendent) is appointed by the Municipality, the Engineer may designate the Superintendent to act as the Engineer's representative. If so designated, the Superintendent will have the power to inspect and direct the execution of the work.

Any instructions given by the Superintendent which change the proposed work or with which the Contractor does not agree shall be referred to the Engineer for final decision.

400.8 ALTERATIONS TO WORK

The Engineer shall have the power to make alterations, additions and/or deletions in the work as shown or described in the Drawings or Specifications and the Contractor shall proceed to implement such changes without delay. Alterations ordered by the Engineer shall in no way render the contract void.

If a landowner desires deviations from the work described on the Drawings, the landowner shall submit a written request to the Engineer, at least 48 hours in advance of the work in question.

In every such case, the contract amount shall be increased or decreased as required according to a fair evaluation of the work completed. Where such changes involve additional work similar to items in the contract, the price for additional work shall be determined after consideration is given to the tendered price for similar items.

In no case shall the Contractor commence work considered to be extra work without the Engineer's approval. Payment for extra work is contingent on receipt of documentation to the satisfaction of the Engineer. Refer to the Extra Work Summary included in the Special Provisions.

400.9 ERRORS AND UNUSUAL CONDITIONS

The Contractor shall notify the Engineer immediately of any error or unusual conditions which may be found. Any attempt by the Contractor to correct the error without notice shall be done at the Contractor's risk. Any additional cost incurred by the Contractor to remedy an error or unusual condition without notice shall be borne by the Contractor. The Engineer shall direct the alteration necessary to correct errors or unusual conditions. The contract amount shall be adjusted in accordance with a fair evaluation of documentation for the work added, deleted or adjusted.

400.10 TESTS

The Engineer reserves the right to subject any materials to a competent testing laboratory for compliance with the standard. If any materials supplied by the Contractor are determined to be inadequate to meet the applicable standards, the Contractor shall bear full responsibility to remove and/or replace all such inadequate materials with materials capable of meeting the standards.

The cost of testing the materials supplied by the Contractor shall be borne by the Contractor.

400.11 BENCHMARKS AND STAKES

Prior to construction, the Engineer will confirm the benchmarks. The Contractor shall be held liable for the cost of replacing any benchmarks destroyed during construction.

If the Engineer provides layout stakes, the Contractor shall be held liable for the cost of replacing any layout stakes destroyed during construction.

Where property bars are shown on the Drawings, they are to be protected and if damaged by the Contractor, they will be reinstated by an Ontario Land Surveyor at the expense of the Contractor. Where property bars not shown on the Drawings are damaged, they will be reinstated by an Ontario Land Surveyor at the expense of the project.

400.12 OPENING UP OF FINISHED WORK

If ordered by the Engineer, the Contractor shall make such openings in the work as are needed to re-examine the work, and shall forthwith make the work good again. Should the Engineer find the work so opened up to be faulty in any respect, the whole of the expense of opening, inspecting and making the work good shall be borne by the Contractor. Should the Engineer find the work opened up to be in an acceptable condition the Contractor shall be paid for the expense of opening and making the work good, unless the Contractor has been obligated by any specification or by the direction of the Engineer to leave the work open for the Engineer's inspection.

400.13 FINAL INSPECTION

Final inspection by the Engineer will be made within twenty (20) days after receiving notice in writing from the Contractor that work is complete, or as soon thereafter as weather conditions permit. All the work included in the contract must at the time of final inspection have the full dimensions and cross-sections.

Prior to commencing the final inspection an on-site meeting may be held by the Engineer and landowners directly affected by the construction of the drain. The Contractor will attend this meeting upon notice by the Engineer.

If there is no on-site meeting with the Engineer and landowners, the Contractor shall obtain from each landowner a written statement indicating that the work has been performed to the owner's satisfaction. If the Contractor is unable to obtain a written statement from the landowner, the Engineer will determine if further work is required prior to issuing the Completion Certificate.

400.14 WARRANTY

There shall be a one-year warranty period on all completed work. The warranty period will commence on the date of the Completion Certificate.

When directed by the Engineer, the Contractor shall repair and make good any deficiencies in the work that may appear during the warranty period.

Before the work shall be finally accepted by the Municipality, the Contractor shall complete all work as directed by the Engineer and remove all debris and surplus materials and leave the work neat and presentable.

400.15 MATERIALS**400.15.1 Concrete Drain Tile**

Concrete drain tile shall conform to the requirements of the most recent ASTM C412 specifications for heavy duty extra quality, unless a stronger concrete tile is required by the Special Provisions or Drawings. All tile furnished shall be subject to the approval of the Engineer.

The minimum nominal lengths of the tile shall be 750mm for 150 to 350mm diameter tile and 1200mm for 400 to 900mm diameter tile.

All tile should be of good quality, free from distortions and cracks and shall meet the standards specified. The ends should be smooth and free from cracks or checks. All rejected tile are to be immediately removed from the site.

Granular backfill, where required, shall consist of approved sand or gravel having no particles retained on a screen having 50mm square openings.

Earth backfill shall consist of approved material having no large lumps or boulders.

400.15.2 Corrugated Plastic Tubing

Corrugated plastic tubing shall conform to the *Land Improvement Contractors of Ontario Standard Specification for Corrugated Plastic Drainage Tubing, 2006*. Type of material (solid or perforated) and need for filter sock will be specified on the Drawings or in the description of the work in the Special Provisions. Filter sock where specified shall be a standard synthetic filter material as provided by a recognized plastic tubing manufacturer unless noted differently on the contract drawings or elsewhere in the contract document. Protect coils of plastic tubing from damage and deformation.

400.15.3 Corrugated Steel Pipe

Corrugated Steel Pipe (CSP) shall be according to OPSS 1801 (CSA G401). Unless stated otherwise in the Special Provisions the pipe shall be:

- galvanized
- helical corrugation with lock seam and re-rolled annular ends
- 68mm x 13mm corrugation profile for diameters up to 1200mm
- 125mm x 25mm corrugation profile for diameters 1200mm and larger
- minimum wall thickness of 1.6mm for diameters up to 500mm
- minimum wall thickness of 2.0mm for diameters 600mm and larger
- joined using standard couplers matching the pipe diameter and material

Other coatings that may be specified include aluminized Type 2 or polymer. Polymer coating shall be a 254mm polymer film laminated to both sides of the pipe.

400.15.4 Plastic Pipe

Plastic Pipe shall be a high density polyethylene (HDPE) double wall corrugated pipe with smooth inner wall, solid with no perforations in accordance with OPSS 1840.

A minimum stiffness of 320 KPa at 5% deflection

The pipe shall be joined with snap-on or split couplers.

400.15.5 Concrete Sewer Pipe

Concrete sewer pipe shall be in accordance with OPSS 1820.

Non-reinforced concrete sewer pipe shall be used for pipe 375mm in diameter and smaller and reinforced concrete sewer pipe shall be used for pipe over 375mm.

Classes shall be as shown on the Contract Drawings or as described in the Form of Tender.

All new concrete sewer pipe shall have rubber-type gasket joints.

Where concrete sewer pipe “seconds” are specified, the pipe should exhibit no damage or cracks on the barrel section and shall be capable of satisfying the crushing strength requirements of OPSS 1820. The pipe may contain cracks or chips in the bell or spigot which prevent the use of rubber gaskets but the joints must be protected with filter cloth.

400.16 RIPRAP

All riprap is to be placed on a geotextile underlay (Terrafix 360R or equal) unless directed otherwise in the specific construction notes. The riprap is to be graded heavy angular stone (quarry stone is recommended) with particles averaging in size from 200mm to 300mm and is to be placed at 300mm thickness. Fine particles may be included to fill voids. Along upstream edges of riprap, where surface water will enter, underlay is to extend a minimum of 300mm upstream from riprap and then be keyed down a minimum of 300mm. Wherever riprap is placed, the area is to be over-dug so that finished top of riprap is at design cross-section, at design elevation or flush with existing ground.

400.17 GEOTEXTILE

To be non-woven fabric that is rot proof, non-biodegradable, chemically resistant to acidic or alkaline soils and is dimensionally stable under different hydraulic conditions. The filter fabric is to be a material whose primary function is to act as a highly permeable, non-clogging soil separator for fine soils (Terrafix 360R or equal). Contractor is to follow the manufacturer's recommendations for cutting, installation and precautions necessary to avoid damage to fabric. Other approved equals will be considered by the Engineer prior to construction.

400.18 DISPOSAL OF MATERIALS

The Contractor shall remove all surplus materials from the job site at the end of the project. The Contractor shall locate the disposal site for all materials to be disposed of. Disposal of materials shall comply with applicable regulations.

400.19 NOTIFICATION OF RAILROADS, ROAD AUTHORITIES AND UTILITIES

Contractor will notify any Railroad, Road Authority or Utility at least 48 hours in advance regarding work to be performed on their property or affecting their infrastructure. The notice will be in writing and is exclusive of Saturdays, Sundays and Holidays.

A utility includes any entity supplying the general public with necessities or conveniences.

400.20 WORKING IN ROAD ALLOWANCES**400.20.1 General**

Work within public road allowances shall be done in accordance with the Ontario Traffic Manual Book 7, latest edition.

400.20.2 Road Crossings

If no specific detail is provided for road crossings on the drawings or in the specifications the following shall apply:

- A Road Authority will supply no labour, equipment or materials for the construction of the road crossing.
- Contractor will not commence road crossing work until any required permits have been obtained. The Engineer may apply for any required permits prior to construction.
- Contractor will notify the Road Authority at least 72 hours in advance of any construction in the road allowance.
- Road crossings may be made with an open cut unless otherwise noted.
- Exact location of crossing shall be verified with the Road Authority and the Engineer.
- Pipe shall be placed on a minimum 150mm depth of Granular A shaped for the pipe.
- Pipe backfill shall be compacted Granular A and extend 300mm above the top of the pipe.
- Trench shall be backfilled with acceptable native material for the base width of the road bed.
- The material shall be placed in lifts not exceeding 300mm in depth and shall be thoroughly compacted with an approved mechanical vibrating compactor.
- Top 600mm of the road bed backfill shall consist of 450mm Granular B and 150mm of Granular A placed in lifts and fully compacted.
- Any surplus excavated material within the road allowance may be spread on the right-of-way with consent of the Road Superintendent otherwise the surplus material shall be hauled away.
- Existing asphalt or concrete pavement or surface treatment shall be replaced by the Contractor to the satisfaction of the Engineer and Road Authority.
- Contractor shall be responsible for correcting any backfill settlement during construction and during the warranty period. Upon approval of the road authority, surplus gravel shall be stockpiled near gravel road crossings to provide backfill for future trench settlement.
- All road crossings shall meet the approval of the Road Authority.
- If any road crossing is not left in a safe manner at the end of the working day barricades and warning signs shall be erected to guarantee the safety of the travelling public.
- If the Engineer deems a road to surface to have been damaged by the construction of a drain, either across or along the road, the Engineer may direct the Contractor to restore the road surface to existing or better condition at no additional cost.

400.20.3 Maintenance of Traffic

Unless directed otherwise on the drawings or in the specifications the Contractor shall keep the road open to traffic at all times. The Contractor shall provide suitable warning signs and/or flagging to the satisfaction of the Road Authority to notify of the construction work.

If a detour is required, the Contractor shall submit a proposal as to the details of the detour for approval by the Road Authority. If necessary to close the road to through traffic, the Contractor shall provide for and adequately sign the detour route. Contractor shall undertake all notifications required for a road closure in consultation with the Municipality.

400.21 LOCATIONS OF EXISTING UTILITIES

The position of pole lines, conduits, watermains, sewers and other underground and overhead utilities are not necessarily shown on the Contract Drawings, and, where shown, the accuracy of the position of such utilities and structures is not guaranteed. Before starting work, the Contractor shall have all utilities located in accordance with the Ontario Underground Infrastructure Notification System Act.

All utilities shall be exposed to the satisfaction of the utility company to verify that the construction proposed will not conflict with the utility structure. Additional payment will be allowed for relocation of utilities if conflicts should occur.

The Contractor is responsible for protecting all located and exposed utilities from damage during construction. The Contractor shall assume liability for damage caused to all properly located utilities.

400.22 LANEWAYS

If no specific detail is provided for laneway crossings on the Drawings or in the Specifications the following shall apply:

- Pipe backfill shall be acceptable native material that can be compacted in place.
- Top 450mm of laneway backfill shall consist of 300mm Granular B and 150mm of Granular A placed in lifts and fully compacted.
- Minimum cover on laneway culverts shall be 300mm.
- Existing asphalt or concrete pavement or surface treatment shall be replaced by the Contractor.
- The width of surface restoration shall match the existing laneway.
- Contractor shall be responsible for correcting any backfill settlement during construction and during the warranty period.

The timing of laneway closures will be coordinated by the Contractor to the satisfaction of the landowner.

400.23 EXISTING CROSSING CLEANOUT

Where the Special Provisions require an existing crossing to be cleaned, the Contractor shall provide a bottom width and depth that provides capacity equivalent to the capacity of the channel on either side. Excavated materials shall be hauled away unless adjacent landowners give permission for leveling. Care shall be taken to ensure that existing abutments or any portion of the structure are not damaged or undercut. The method of removing the material is to be pre-approved by the Engineer.

400.24 FENCES

If the Contractor is responsible to remove and install fences, the following shall apply:

- All fences removed by a Contractor are to be re-erected in as good a condition as existing materials permit.
- All fences shall be properly stretched and fastened. Where directed by the Engineer, additional steel posts shall be placed to adequately support a fence upon re-erection.
- Where practical and where required by the landowner, the Contractor shall take down an existing fence at the nearest anchor post and roll the fence back rather than cutting the fence and attempting to patch it.
- Where fence materials are in such poor condition that re-erection is not possible, the Contractor shall replace the fence using equivalent materials. Such fence material shall be approved by the Engineer and the landowner. Where the Engineer approves new fence material, additional payment will be provided.

Any fences paralleling an open drain, that are not line fences, that hinder the proper working of the excavating machinery for drain construction or maintenance shall be removed and rebuilt by the landowner at their own expense. If such parallel fences are line fences they shall be removed and reinstalled by the Contractor.

No excavated or cleared material shall be placed against fences.

The installation of all fences shall be done to the satisfaction of the Engineer and the landowner.

400.25 LIVESTOCK

If any construction will be within a fenced field containing livestock that are evident or have been made known to the Contractor, the Contractor shall notify the owner of the livestock 48 hours in advance of access into the field. Thereafter, the owner shall be responsible for the protection of the livestock in the field during construction and shall also be liable for any damage to or by the livestock.

Where the owner so directs or where the Contractor has failed to reach the owner, the Contractor shall adequately re-erect all fences at the end of each working day. No field containing livestock shall have a trench left open at the end of the working day, unless the trench has been adequately backfilled or protected. Failure of the Contractor to comply with this paragraph shall render the Contractor liable for any damage to or by the livestock.

Where livestock may be encountered on any property the Contractor shall notify the Engineer to arrange for inspection of the work prior to backfilling.

400.26 STANDING CROPS

The Contractor shall not be held responsible for damages to standing crops within the working area for the drain. However, the Contractor shall notify the owner of the crops 48 hours prior to commencement of construction so as to allow the owner an opportunity to harvest or salvage the crop within the drain working area. If this advance notice is not given the Contractor may be liable for the loss of the standing crops.

400.27 CLEARING VEGETATION

400.27.1 General

The area for clearing, if not defined elsewhere, shall be 15m on each side of the drain.

400.27.2 Trees to Remain

Where it is feasible to work around existing trees that do not impede the function of the drainage works, the Contractor shall not remove any deciduous tree larger than 300mm and any coniferous tree larger than 200mm, unless authorized by the Engineer.

400.27.3 Incidental Clearing

Incidental clearing includes removal of trees, brush or other vegetation with an excavator during construction activities, and the cost is to be included in the price for the related construction activity.

400.27.4 Power Brushing

Power brushing includes removal of above-ground vegetation with a rotary brush cutter or other mechanical means. Stump and root removal is not required. Power brushed vegetation in a channel cross-section shall be removed and leveled in the working area. Excavated material may be placed and leveled on power brushed vegetation.

400.27.5 Close-Cut Clearing

Close-cut clearing includes removal of above-ground vegetation cut flush with the ground. Stump and root removal is not required.

400.27.6 Clearing And Grubbing

Clearing and grubbing includes removal of vegetation, including stumps and roots. Removal of earth from the grubbed area into the windrows or piles is to be minimized.

400.27.7 Disposal of Cleared Vegetation**400.27.7.1 In Bush Areas**

Cleared vegetation is to be pushed into windrows or piles at the edge of the cleared area. Stumps and roots are to be piled first at the edge of the cleared area, followed by other vegetation (trunks, branches, etc.). Provisions for lateral drainage are required through all windrows. Windrows are not to block any laneways or trails. After removing cleared vegetation, the working area shall be leveled to the satisfaction of the Engineer.

400.27.7.2 In Field Areas

Cleared vegetation resulting from incidental clearing or power brushing may be hauled away, mulched in place or reduced to a size that permits cultivation using conventional equipment without causing undue hardship on farm machinery.

Cleared vegetation resulting from close-cut clearing or clearing and grubbing is to be hauled away to an approved location. Disposal sites may be in bush areas or other approved locations on the same farm. No excavated material shall be levelled over any logs, brush or rubbish of any kind.

400.27.8 Landowner Requested Salvage

A landowner may request that wood be separated from the windrows for the landowner's future use. This additional work would be eligible for extra payment, subject to the approval of the Engineer. The cost of the additional work would be assessed to the landowner.

400.27.9 Clearing by Landowner

Wherever the Special Provisions indicate that clearing may be undertaken by the landowner, work by the landowner shall be in accordance with the Clearing Vegetation requirements of this specification and must be completed so as not to cause delay for the Contractor. If the landowner does not complete clearing in accordance with these requirements, the Contractor will undertake the clearing at a price approved by the Engineer.

400.28 ROCK REMOVAL**400.28.1 General**

Rock shall be defined as bedrock and boulders that are greater than one-half cubic metre in size and that require blasting or hoe-ram removal. Bedrock or boulders that can be removed with a standard excavator bucket are not considered rock removal.

400.28.2 Blasting Requirements

All blasting shall be performed by a competent, qualified blaster in accordance with OPSS 120. Blasting mats are required. A pre-blast survey meeting the requirements of OPSS 120 must be completed for any structure within 200m of any blasting. The cost for pre-blast survey shall be included in the tender price for rock removal.

400.28.3 Typical Sections and Pay Limits

For tile drains and road culverts, rock shall be removed to 150mm below the proposed grade shown on the profile so that pipes are not in direct contact with rock. The width of rock removal shall be 1m minimum or the diameter of the pipe plus 600mm.

For open drains, rock removal shall match the proposed grade and bottom width shown on the Drawings. Side slopes shall be vertical or sloped outward. Side slopes shall be free of loose rock when excavation is completed.

Payment for the quantity of rock removed will be based on the typical sections described in these specifications and confirmed by field measurements. There will be no payment for overbreak.

400.28.4 Disposal of Rock

Excavated rock shall be piled at the edge of the working area at locations designated by the landowner. The cost to pile excavated rock shall be included in the tender price for rock removal. If the Special Provisions or the landowner require excavated rock to be hauled away, additional payment will be considered.

Where approved by the Engineer, excavated rock may be used in place of imported riprap.

400.29 SEEDING

400.29.1 General

Contractor responsible for re-seeding as necessary for uniform catch during warranty period. Areas that remain grassed after construction may not need to be seeded unless directed otherwise by the Engineer.

400.29.2 Drainage Works and Road Allowances

All disturbed ditch banks, berms and road allowances are to be seeded at the end of the day.

The following seed mixture shall be applied at 60kg/ha using a mechanical (cyclone) spreader:

- 35% Creeping Red Fescue
- 25% Birdsfoot Trefoil
- 25% Kentucky Bluegrass
- 10% Cover Crop (Oats, Rye, Barley, Wheat)
- 5% White Clover

Provide temporary cover for late fall planting by adding an additional 10 kg/ha of rye or winter wheat.

400.29.3 Hydroseeding

Where hydroseeding is specified, disturbed areas will be restored by the uniform application of a standard roadside mix, fertilizer, mulch and water at a rate of 2,000 kg/ha and be in accordance with OPSS 804.

400.29.4 Seeding Lawns

Unless specified otherwise, lawn areas shall be seeded with Canada No. 1 lawn grass mixture applied at 300 kg/ha using a mechanical (cyclone) spreader on 100mm of topsoil. Fertilizer shall be 5:20:20 or 10:10:10 applied at 300 kg/ha. Seed and fertilizer shall be applied together. Contractor shall arrange for watering with landowners.

400.29.5 Sod

Where sod is specified, sod is to be commercial grade turfgrass nursery sod, Kentucky Bluegrass placed on 50mm of topsoil. Fertilizer shall be 5-20-20 applied at 10kg/ha. Place sod in accordance with supplier instructions. Contractor is responsible for saturating the sod with water on the day of sod placement. Subsequent watering is the responsibility of the landowner.

400.30 EROSION CONTROL BLANKETS

Erosion Control Blankets (ECB) shall be biodegradable and made of straw/coconut (Terrafix SC200, Nilex SC32 or equal) or coconut (Terrafix C200, Nilex C32 or equal) with photodegradable, double net construction. The blanket and the staples shall be supplied and installed as per OPSS 804.

Erosion control blanket shall be placed and stapled into position as per the manufacturer's installation instructions on slopes as directed by the Engineer. Blankets shall be installed in direct contact with the ground surface to form a uniform, cohesive mat over the seeded earth area. The blankets are to be single course with 150mm overlap between blankets and joints are to be staggered. The Contractor shall ensure that the ECB is anchored to the soil and that tenting of the ECB does not occur.

On slopes, when the ECB cannot be extended 1m beyond the crest of the slope, the uppermost edge of the ECB shall be anchored in a 150mm wide by 150mm deep trench. The trench shall be backfilled with earth and compacted.

400.31 SEDIMENT CONTROL**400.31.1 General**

Contractor shall install sediment control features at the downstream limits of the project and at other locations as shown on the drawings or directed by the Engineer.

Sediment control features shall be installed prior to any excavation taking place upstream of that location. The Contractor shall maintain all sediment control features throughout construction and the warranty period.

Sediment that accumulates during construction shall be removed and levelled as required.

400.31.2 Flow Check Dams**400.31.2.1 Temporary Straw Bale Flow Check Dam**

The straw bale flow check dam shall consist of a minimum of 3 bales. Each bale is to be embedded at least 150mm into the channel bottom and shall be anchored in place with 2 T-bar fence posts or 1.2m wooden stakes driven through the bale.

Straw bales shall be hauled away at the end of the warranty period. Accumulated sediments shall be excavated and levelled when the temporary straw bale flow check dam is removed.

400.31.2.2 Temporary Rock Flow Check Dam

The temporary rock flow check dam shall extend to the top of the banks so that dam overtopping does not cause bank erosion. Rock shall be embedded a minimum of 150mm into the ditch bottom and banks. No geotextile is required for temporary rock flow check dams.

Accumulated sediments shall be excavated and levelled when the temporary rock flow check dam is removed at the conclusion of the warranty period.

400.31.2.3 Permanent Rock Flow Check Dam

The requirements of temporary rock flow check dams shall apply except rock shall be placed on geotextile and the dam shall remain in place permanently.

400.31.3 Sediment Traps**400.31.3.1 *General***

The channel bottom shall be deepened in accordance with the dimensions provided in the Drawings or Special Provisions. If dimensions are not specified on the Drawings, the sediment trap shall be excavated within the channel cross-section at least 0.3m below the design grade.

The Contractor will monitor the sediment trap during construction and cleanout accumulated sediments as required to maintain the function of the sediment trap.

If specified to be temporary, no sediment trap maintenance is required after construction is complete.

If specified to be permanent, the contractor will clean out the sediment trap at the conclusion of the warranty period, unless directed otherwise by the Engineer.

400.31.3.2 *Sediment Trap with Flow Check Dam*

A permanent rock sediment trap shall include a permanent sediment trap and a rock flow check dam.

A temporary rock/straw sediment trap shall include a temporary sediment trap and a rock/straw flow check dam.

400.31.4 Turbidity Curtains

A turbidity curtain is required when there is permanent water level/flow and a sediment trap is not feasible.

Turbidity curtains shall be in accordance with OPSS 805 and installed per manufacturer's instructions.

Turbidity curtains shall be sized and anchored to ensure the bottom edge of the curtain is continuously in contact with the waterbody bed so that sediment passage from the enclosed area is prevented. The curtain must be free of tears and capable of passing the base flow from the drainage works. Turbidity curtain locations may be approved by the Engineer.

Turbidity curtains are to remain functional until work in the enclosed area is completed. Prior to relocating or removing turbidity curtains, accumulated sediment is to be removed from the drain and levelled.

Where a turbidity curtain remains in place for more than two weeks it shall be inspected for damage or clogging and replaced, repaired or cleaned as required.

400.31.5 Silt Fence

Silt fence shall be in accordance with OPSS 805.07.02.02 and OPSD 219.110 (light-duty).

400.32 GRASSED WATERWAYS AND OVERFLOW SWALES

Grassed waterways and overflow swales typically follow low ground along the historic flow route. The cross-section shall be saucer shaped with a nominal 1m bottom width, 8:1 side slopes and 300mm depth unless stated otherwise in the Special Provisions.

All grassed waterways are to be permanently vegetated. Grassed waterways shall be seeded with the following permanent seed mixture: 50% red fescue, 45% perennial ryegrass and 5% white clover, broadcast at 80 kg/ha. Fertilizer to be 7-7-7 applied at 80 kg/ha.

Provide temporary cover for late fall planting by adding an additional 10 kg/ha of rye or winter wheat.

Overflow swales may be cropped using conventional farming practice.

400.33 BUFFER STRIPS

Open drains shall include minimum 3m wide, permanently vegetated buffer strips on each side of the drain. Catchbasins shall include a minimum 1m radius, vegetated buffer strip around the catchbasin.

Cultivation of buffer strips using conventional farming practice may be undertaken, provided sediment transport into the drain is minimized.

400.34 MAINTENANCE CORRIDOR

The maintenance corridor along the route of the drain, as established in the report, shall be kept free of obstructions, ornamental vegetation and structures. When future maintenance is undertaken, the cost of removing such items from the corridor shall be assessed to the landowner.

400.35 POLLUTION

The Contractor shall keep their equipment in good repair. The Contractor or any landowner shall not spill or cause to flow any polluted material into the drain that is not acceptable to the MECP. The local MECP office and the Engineer shall be contacted if a polluted material enters the drain. The Contractor shall refill or repair equipment away from open water. If the Contractor causes a spill, the Contractor is responsible to clean-up the spill in accordance with MECP clean-up protocols.

400.36 SPECIES AT RISK

If a Contractor encounters a known Species At Risk designated by the MECP, MNRF or DFO, the Contractor shall notify the Engineer immediately and follow the Ministry's guidelines for work around the species.

STANDARD SPECIFICATIONS

FOR

OPEN DRAINS

TABLE OF CONTENTS

410.1 DESCRIPTION..... 1

410.2 MATERIALS 1

410.3 CONSTRUCTION..... 1

 410.3.1 Excavation..... 1

 410.3.2 Low Flow Channels 1

 410.3.3 Line 1

 410.3.4 Grade Control..... 1

 410.3.5 Variation from Design Grade 2

 410.3.6 Excavated Material 2

 410.3.7 Excavation at Existing Bridge and Culvert Sites 3

 410.3.8 Bridges and Culverts 3

 410.3.9 Obstructions 3

 410.3.10 Tile Outlets 4

 410.3.11 Completion 4

410.1 DESCRIPTION

Work under this item shall include the supply of labour, equipment and materials required for: channel excavation to the cross-section specified, leveling or disposal of all excavated material (spoil) as directed, reconstruction of all intercepted drains as required and any other items related to open drain construction as required by the Schedule of Tender Prices, Special Provisions or the Drawings.

410.2 MATERIALS

Refer to Section 400, Standard Specifications for Drain Construction for any materials required for open drain construction.

410.3 CONSTRUCTION**410.3.1 Excavation**

The bottom width and the side slopes of the ditch shall be as shown on the profile drawing. If the channel cross-section is not specified in the Special Provisions it shall be a 1m bottom width with 1.5m horizontal to 1m vertical (1.5:1) bank slope. At locations along the drain where the specified side slopes change there shall be a transitional length of not less than 5m between the varying side slopes. At locations along the drain where the specified bottom width changes there shall be a transitional length of not less than 5m. In all cases there shall be a smooth transition between changes in any part of the channel cross-section. Where the bottom width of the existing ditch matches the specified bottom width, ditch excavation shall be completed without disturbing existing banks.

410.3.2 Low Flow Channels

Unless specified otherwise in the Special Provisions, all intermittent open drains with a bottom width greater than 1.8m and a grade less than 0.07%, shall have a low flow channel. The bottom of the low flow channel shall be the grade shown on the profiles.

The low flow channel shall have a U-shaped cross-section with an average top width of 0.5m and a minimum depth of 0.3m. The low flow channel will not be seeded and may meander along the main channel bottom provided it remains at least .3m from the toe of main channel bank slope.

410.3.3 Line

The drain shall be constructed according to the alignment shown on the drawings or shall follow the course of the existing ditch. All bends shall have a minimum inside radius of 2m. There shall be a smooth transition between changes in the channel alignment. The Contractor shall contact the Engineer before removing any bends or irregularities in an existing ditch.

410.3.4 Grade Control

The profile shows the grade line for the bottom of the ditch. Cuts may be shown on the profile from the existing top of bank and/or from the existing ditch bottom to the new ditch bottom. These cuts are shown for the convenience of the Contractor and are not recommended for quantity estimate or grade control. Accurate grade control must be maintained by the Contractor during ditch excavation. The ditch bottom elevation should be checked every 50 metres and compared to the elevation on the profile.

Benchmarks are identified on the Contract Drawings. The Engineer will confirm all benchmark elevations prior to construction.

410.3.5 Variation from Design Grade

A variation of greater than 25mm above the design grade line may require re-excavation. Excavation below design grade up to 150mm is recommended so that sediment accumulation during or following excavation will not place the ditch bottom above the design grade at completion. Under some circumstances the Engineer may direct that over excavation greater than 200mm will have to be backfilled. No additional payment will be made if backfilling is required to remedy over excavation.

410.3.6 Excavated Material

Excavated material (spoil) shall be deposited on either or both sides of the drain within the specified working area as directed in the Special Provisions. The Contractor shall verify the location for the spoil with each landowner before commencing work on their property. If not specified, spoil shall be placed on the low side of the ditch or opposite trees and fences. The spoil shall be placed a minimum 1m from the top of the bank. No excavated material shall be placed in tributary drains, depressions, or low areas such that water is trapped behind the spoil bank. Swales shall be provided through the leveled or piled spoil at approximately 60m intervals to prevent trapping water behind the spoil bank.

The excavated material shall be placed and leveled to a maximum depth of 250mm; unless otherwise instructed. If excavating more than 450mm topsoil shall be stripped, stockpiled separately and replaced over the leveled spoil, unless stated otherwise in the Special Provisions. The edge of the spoil bank furthest from the ditch shall be feathered down to existing ground. The edge of the spoil bank nearest the ditch shall have a maximum slope of 2:1. The material shall be leveled such that it may be cultivated with conventional equipment without causing undue hardship on farm machinery.

Wherever clearing is necessary prior to leveling, the Contractor shall remove all stumps and roots from the working area. No excavated material shall cover any logs, brush or rubbish of any kind. Large stones in the leveled spoil that are greater than 300mm in diameter shall be moved to the edge of the spoil bank nearest to the ditch but in general no closer than 1m to the top of bank.

Lateral channels that outlet into the drain shall be tapered over a distance of 10m to match the grade of drain excavation. No additional payment will be made for this work.

Where the elevation difference between the lateral channel and the drain is greater than 450mm, a rock chute or similar bank protection approved by the Engineer shall be provided. Additional payment may be allowed for this work.

Where it is specified to straighten any bends or irregularities in the alignment of the ditch or to relocate any portion of an existing ditch, the excavation from the new cut shall be used for backfilling the original ditch. Regardless of the distance between the new ditch and old ditch, no additional payment will be allowed for backfilling the existing ditch.

The Contractor shall contact the Engineer if a landowner indicates in writing that spoil on the owner's property does not need to be leveled. The Engineer may release the Contractor from the obligation to level the spoil and the Engineer shall determine the credit to be applied to the Contractor's payment. No additional compensation is provided to the owner if the spoil is not leveled.

The Engineer may require the Contractor to obtain written statements from any or all of the landowners affected by the leveling of the spoil. Final determination on whether or not the leveling of spoil meets the specification shall be made by the Engineer.

410.3.7 Excavation at Existing Bridge and Culvert Sites

The Contractor shall excavate the drain to the specified depth under all bridges and to the full width of the structure unless specified otherwise in the Special Provisions. All necessary care and precautions shall be taken to protect permanent structures. Temporary bridges may be removed and left on the bank of the drain. In cases where the design grade line falls below the top of footings, the Contractor shall take care to not over-excavate below the grade line. The Contractor shall notify the Engineer if excavation of the channel exposes the footings of the bridge or culvert, so the Engineer can make an evaluation.

The Contractor shall clean through all pipe culverts to the grade line and width specified on the profile. The Contractor shall immediately contact the Engineer after a culvert cleanout if it is found that the culvert bottom is above the grade line or where the structural integrity of the culvert is questionable.

Material resulting from cleanout through bridges or culverts shall be levelled on the adjacent private lands or hauled offsite at the expense of the bridge/culvert owner.

410.3.8 Bridges and Culverts

The size and material for any new ditch crossings shall be as outlined in the Special Provisions.

For culvert installation instructions, refer to the General Specifications for Drain Construction and the Drawings.

Any crossings assembled on-site shall be assembled in accordance with the manufacturer's specifications.

If directed on the drawings that the existing crossing is to be salvaged for the owner, the Contractor shall carefully remove the existing crossing and place it beside the ditch or haul to a location as specified by the owner. If the existing crossing is not to be saved then the Contractor shall remove and dispose of the existing crossing. Disposal by burying on-site must be approved by the Engineer and the owner.

All new pipe crossings shall be installed at the invert elevations as specified on the Drawings, usually a minimum of 50mm below design grade. If the ditch is over excavated greater than 200mm below design grade the Contractor shall confirm with the Engineer the elevations for installation of the new pipe crossing.

For backfill and surface restoration, refer to the General Specifications for Drain Construction and the Drawings.

Installation of private crossings during construction must be approved by the Engineer.

410.3.9 Obstructions

All trees, brush, fallen timber and debris shall be removed from the ditch cross-section and as required for spreading of the spoil. The roots shall be left in the banks if no bank excavation is required as part of the new channel excavation. In wooded or heavily overgrown areas all cleared material may be pushed into piles or rows along the edge of the cleared path and away from leveled spoil. All dead trees along either side of the drain that may impede the performance of the drain if allowed to remain and fall into the ditch, shall be removed and put in piles, unless directed otherwise by the Engineer.

410.3.10 Tile Outlets

The location of all existing tile outlets may not be shown on the profile for the drain. The Contractor shall contact each owner and ensure that all tile outlets are marked prior to commencing excavation on the owner's property. If a marked tile outlet or the tile upstream is damaged due to construction, it shall be replaced at the Contractor's expense. Additional payment will be allowed for the repair or replacement of any unmarked tile outlets encountered during excavation. In all cases, if an existing tile outlet requires replacement the Contractor shall confirm the replacement tile outlet with the Engineer. Where riprap protection exists at any existing tile outlet such protection shall be removed and replaced as necessary to protect the outlet after reconstruction of the channel.

If any tile outlet becomes plugged as a result of construction, the Contractor shall remove the obstruction.

410.3.11 Completion

At the time of final inspection, all work in the contract shall have the full dimensions and cross-sections specified.

STANDARD SPECIFICATIONS**FOR****TILE DRAINS****TABLE OF CONTENTS**

420.1	DESCRIPTION	1
420.2	MATERIALS	1
420.3	CONSTRUCTION.....	1
420.3.1	Outlet	1
420.3.2	Line	1
420.3.3	Grade Control	2
420.3.4	Variation from Design Grade.....	2
420.3.5	Installation	2
420.3.6	Backfilling	3
420.3.7	Tile Connections	3
420.3.8	Stones and Rock	4
420.3.9	Brush, Trees and Debris	4
420.3.10	Subsoil Instability	4
420.3.11	Broken or Damaged Tile	4
420.3.12	Excess Tile	4
420.3.13	Catchbasins	5
420.3.14	Junction Boxes	5

420 STANDARD SPECIFICATIONS FOR TILE DRAINS**420.1 DESCRIPTION**

Work under this specification will consist of supplying, hauling, laying and backfilling subsurface drainage conduit with the conduit materials as described on the Drawings and in the location, depth and invert grade as shown on the Drawings. In this specification the word "tile" will apply to all described conduit materials. Lengths are in millimeters (mm) and meters (m).

The work shall include the supplying of all labour, tools, equipment and extra materials required for the installation of the tile; the excavation and backfilling of the trenches; the hauling, handling, placing and compaction of the excavated material for backfill, the loading, hauling, handling and disposal of surplus excavation material; the removal and replacing of topsoil and sod where required by the Engineer.

All existing laterals crossed by the new line shall be reconnected in an approved manner. Either special manufactured connections shall be used or another method of sealing connections as approved by the Engineer. The Contractor shall also construct catchbasins, junction boxes and other structures where directed by the Engineer.

Except where complete removal of an existing pipe is required by new construction, existing pipes to be abandoned shall be sealed with a concrete or mortar plug with a minimum length of 300mm to the satisfaction of the Engineer.

Sections 6 and 7 of the current version of the *Drainage Guide for Ontario*, OMAFRA Publication 29 shall provide a general guide to all methods and materials to be used in the construction of tile drains except where superseded by this Contract.

The licensing requirements of the *Agricultural Tile Drainage Installation Act, 1990* will not be applicable to this Contract unless specified otherwise by this Contract.

420.2 MATERIALS

Refer to Section 400, Standard Specifications for Drain Construction for any materials required for tile drain construction.

420.3 CONSTRUCTION**420.3.1 Outlet**

A tile drain outlet into a ditch or creek shall be protected using a 6m length of rigid pipe with a hinged grate for rodent protection. Maximum spacing between bars on the rodent grate shall be 50mm. Material for rigid pipe will be specified in the Special Provisions, plastic pipe is preferred. The joint between the rigid pipe and the tile drain shall be wrapped with filter fabric. All outlets will be protected with rock riprap to protect the bank cut and as a splash apron. In some locations riprap may also be required on the bank opposite the outlet. The quantity of riprap required will be specified in the Special Provisions. A marker stake as approved by the Engineer shall be placed at each tile outlet.

420.3.2 Line

The Engineer will designate the general location of the new drain. A landowner may indicate a revised location for the drain which must be approved by the Engineer. Where a change in alignment is required that is not accommodated in a catchbasin, junction box or similar structure the alignment change shall run on a curve with a radius not less than the minimum installation radius specified for the tile material.

The Contractor shall exercise care to not disturb any existing tile drains which parallel the course of the new drain, particularly where the new and existing tile act together to provide the necessary capacity. Where an existing tile is disturbed or damaged the Contractor shall perform the necessary correction or repair with no additional compensation.

NOTE: It is the Contractor's responsibility to ascertain the location of, and to contact the owners of all utility lines, pipes and cables in the vicinity of drain excavations. The Contractor shall be completely responsible for all damages incurred.

420.3.3 Grade Control

Tile is to be installed to the elevation and grade shown on the profiles. Accurate grade control must be maintained by the Contractor at all times during tile installation. The tile invert elevation should be checked every 50m and compared to the elevation on the profile.

Benchmarks are identified on the Contract Drawings. The Engineer will confirm all benchmark elevations prior to construction.

420.3.4 Variation from Design Grade

No reverse grade will be allowed. A small variation in grade can be tolerated where the actual capacity of the drain exceeds the required capacity. The constructed grade should be such that the drain will provide the capacity required for the drainage area. Constructed grade should not deviate from design grade by more than 10% of the internal diameter for more than 25m. Grade corrections shall be made gradually over a distance not less than 10m.

420.3.5 Installation

At each work stoppage, the exposed end of the tile shall be covered by a tight fitting board or metal plate. No installed tile shall be left exposed overnight. Any tile damaged or plugged during construction shall be replaced or repaired at the Contractor's expense.

Topsoil over the trench shall be stripped, stockpiled separately and replaced after the trench is backfilled. Where installation is across a residential lawn, existing sod over the trench shall be cut, lifted and replaced in a workmanlike manner or new sod laid to match pre-construction conditions.

420.3.5.1 Installation of Concrete Tile

Concrete tile shall be installed by a wheel trencher unless an alternate method of construction is noted on the Drawings.

Digging of the trench shall start at the outlet end and proceed upstream. The location and grade shall be as shown on Drawings but shall be liable to adjustment or change by the Engineer on site with no additional payment allowed except where the change involves increased depth of cut beyond the limitation of the wheel trencher in use at the time of the change. The trench width measured at the top of the tile should be at least 150mm greater than the tile diameter.

The bottom of the trench is to be cut accurately to grade and shaped so that the tile will be embedded in undisturbed soil or in a compacted bed at least for 10% of its overall height. Where hard shale, boulders or other unsuitable bedding material is encountered, the trench shall be excavated to 75mm below grade and backfilled with granular material compacted to a shaped, firm foundation. If the trench is overcut below the proposed grade, it is to be backfilled with granular material to the correct grade and compacted to a shaped, firm foundation.

Where the depth for the tile installation exceeds the depth capacity of the wheel trencher the Contractor shall excavate a trench of sufficient depth so that the wheel trencher can install the tile at the correct depth and grade. The tender price shall include the cost of the additional excavation and backfilling and stripping and replacing topsoil over the trench.

The inside of the tile is to be kept clean during installation. All soil and debris should be removed before the next tile is laid. Maximum spacing at joints between tiles should be about 3mm. Directional changes can be made without fittings or structures provided the centre-line radius of the bend is not less than 15m radius. The tiles are to be beveled, if necessary, to ensure close joints on all bends.

All tile joints and connections with other pipe materials are to be fully and tightly wrapped with a minimum 300mm width of geotextile drain wrap. A 150mm overlap on top is required. No additional payment will be made for joint wrapping.

420.3.5.2 *Installation of Corrugated Plastic Tubing*

Corrugated plastic tubing shall be installed by a drainage plow or wheel trencher unless an alternate method of construction is specified on the Drawings. For other installation methods, proper bedding and backfill is required to maintain the structural integrity of the plastic tubing so that surface and earth loads do not deflect the tubing by more than 20% of its nominal diameter.

For all installation methods:

- the plastic tubing should not be stretched by more than 7% of its normal length
- protect tubing from floating off grade when installing in saturated soil conditions
- directional changes can be made without fittings provided the centre-line radius of the bend is not less than five times the tubing diameter

Drainage plow equipment should construct a smooth bottomed opening in the soil and maintain the opening until the tubing is properly installed. The size of the opening in the soil should conform closely to the outside diameter of the tubing.

420.3.5.3 *Installation of Concrete Sewer Pipe or Plastic Pipe*

The Contractor may install pipe using a wheel trencher. For concrete sewer pipe, the bells must be recessed.

The Contractor may install pipe using an excavator by shaping the bottom of the trench to receive and support the pipe over 10% of its diameter if the trench is backfilled with native material. Shaping the trench bottom is not required where 150mm of granular bedding is placed to the satisfaction of the engineer.

420.3.6 **Backfilling**

All tile should be blinded by the end of the day's work to protect and hold them in place against disturbances. After tile is inspected, it shall initially be backfilled with a minimum cover of 300mm.

For blinding and initial backfilling use clean native soil with no organic matter. Initial backfill shall be tamped around the pipe by backhoe bucket or similar if directed by the Engineer.

The tile shall be backfilled with native material such that there is a minimum cover of 600mm. In addition, a sufficient mound must be placed over the trench to ensure that no depression occurs after settling along the trench.

420.3.7 **Tile Connections**

All lateral drains encountered along the route of the new tile drain are to be connected to the new drain if the intercepted tile are clean and do not contain polluted water. Lateral drains that are full of sediments or contain polluted waters will be addressed by the Engineer at the time of construction. All lateral drains are to be connected to the new tile using a pipe material and size that will provide the same flow capacity as the existing lateral drain unless a different connection is described in the Special Provisions. Corrugated plastic tubing can be used for all tile connections. Tubing can be solid or perforated, filter sock is not required. Contractor is responsible for installation and backfilling in a manner that maintains the structural integrity of the connection. Manufactured fittings should be used to ensure tight connections. Where an opening must

be made in the new tile drain for a connection, the opening shall be field cut or cored. After the opening is cut in the new tile any gaps or voids around the connection shall be sealed with mortar, low-expanding spray foam or geotextile. Lateral tubing shall not protrude more than 25mm beyond the inside wall of the new tile drain. The Contractor shall ensure that any material used to seal the connection does not protrude beyond the inside wall of the new tile drain.

All connections that are described in the Special Provisions are considered to be part of the original Contract price. For all other connections the Contractor will be paid in accordance with the price established in the Schedule of Tender Prices. The Contractor must list all connections on the Lateral Connection Summary sheet, if included in the Special Provisions, in order to qualify for payment. The Lateral Connection Summary sheet describes all tile encountered based on location (station), side of trench, size and type of tile and approximate length and type of material used for the connection.

420.3.8 Stones and Rock

The Contractor shall immediately contact the Engineer if bedrock or stones of sufficient size and number are encountered such that installation by wheel trencher cannot continue. The Engineer may direct the Contractor to use some other method of excavation to install the tile. The basis of payment for such extra work shall be determined by the Engineer. Stones greater than 300mm in diameter that are removed during excavation shall be disposed of by the Contractor at an offsite location. No additional payment for excavating or hauling these stones will be provided.

420.3.9 Brush, Trees and Debris

Unless stated otherwise in the Special Provisions, the following requirements shall apply for installation of a tile drain in a wooded area. The Contractor will clear and grub a minimum corridor width of 30m centered on the tile drain alignment. The resulting debris shall be placed in a windrow along the edge of the working area. No additional payment will be made for such work.

420.3.10 Subsoil Instability

If poor subsoil conditions are encountered during tile installation by wheel trencher an attempt shall be made to install the tile with a continuous geotextile underlay in the trench bottom. The cost of the underlay, if approved by the Engineer, will be paid as an extra. If the continuous geotextile underlay is not sufficient then the tile will be installed by backhoe or excavator on a bedding of 19mm clear crushed stone (300mm depth) to achieve trench bottom stability for the new tile. If approved, the above work will be paid based on the unit price provided on the Form of Tender. The unit price shall include the cost to supply and place the stone. If more than 300mm depth of stone is required for bottom stability, additional payment will be allowed for the additional depth of stone. The additional quantity of stone shall be supported by weigh tickets and the suppliers invoice.

If poor subsoil conditions are encountered during tile installation by backhoe or excavator, the tile shall be installed on stone bedding as noted above. For this installation only the material cost of the stone will be paid as an extra. Supply of stone and cost to be supported by weigh tickets and supplier's invoice.

If the subsoil is a fine grained soil it may necessary to place the stone on a geotextile with the geotextile wrapped over the stone before laying the tile. Additional payment will be allowed to supply and install the geotextile.

420.3.11 Broken or Damaged Tile

The Contractor shall dispose of all damaged or broken tile and broken tile pieces off-site.

420.3.12 Excess Tile

All excess tile shall be removed from the job site.

420.3.13 Catchbasins**420.3.13.1 General**

All catchbasins shall have minimum inside dimensions matching the dimensions shown on the Drawings. Contractor is responsible for ordering catchbasins to match the inlet and outlet connections and top elevations required by the Special Provisions and the Drawings.

420.3.13.2 Materials

Requirements in this section apply to catchbasins in non-travelled locations. Where catchbasins are proposed for travelled locations, refer to the Special Provisions and the Drawings for applicable OPSD information.

Precast concrete catchbasins shall be manufactured by Coldstream Concrete or approved equal. Minimum wall thickness for catchbasins without reinforcement is 150mm and with reinforcement 100mm. The joints between precast catchbasin sections shall be protected with geotextile to prevent soil material from entering into the catchbasin. Joint protection using mortar or water tight barrier is also acceptable. Grates are to be birdcage grates as manufactured by Coldstream Concrete or approved equal unless specified otherwise on the Drawings. All grates to be secured with corrosion resistant hardware.

HDPE catchbasins shall be as fabricated by ADS, Armtec, Hancor or approved equal. Steel catchbasins shall be the Heavy Duty Steel Catch Basin as manufactured by AgriDrain or approved equal. PVC catchbasins shall be Nyloplast as manufactured by ADS or approved equal. HDPE, steel and PVC catchbasins shall be supplied with integral stubouts fabricated by the manufacturer and sized according to the pipe connections shown on the Drawings. Grates for HDPE, steel or PVC catchbasins shall be in accordance with the Special Provisions and manufacturer recommendations.

Marker stakes as supplied by Coldstream Concrete or equal are to be placed beside each catchbasin unless specified otherwise on the Drawings.

420.3.13.3 Installation

All tile or pipe connected to concrete catchbasins shall be mortared or secured in place so that no gaps remain at the connection. Mortar is to be applied on both the inside and outside wall surfaces.

Backfill around all new catchbasins is recommended to be 19mm clear crushed stone to avoid future settlements. The Contractor shall be responsible for backfilling all settlement areas around catchbasins during the contract warranty period. No additional payment will be provided for adding backfill to settlement areas around catchbasins.

All catchbasin sumps to be fully cleaned by the Contractor after completion of drain installation and backfilling.

420.3.14 Junction Boxes

Junction boxes shall be precast concrete to the same specification as above for catchbasins except that the junction box shall have a solid lid. The lid shall be a minimum of 125mm thick with wire mesh reinforcement and 2 lifting handles. The top of the junction box should have a minimum ground cover of 450mm.

THE POSITION OF POLE LINES, CONDUITS, WATERMAINS, SEWERS AND OTHER UNDERGROUND AND OVERGROUND UTILITIES AND STRUCTURES IS NOT NECESSARILY SHOWN ON THE CONTRACT DRAWINGS, AND, WHERE SHOWN, THE ACCURACY IS NOT GUARANTEED. BEFORE STARTING WORK, THE CONTRACTOR SHALL BE INFORMED OF THE EXACT LOCATION OF ALL SUCH UTILITIES AND STRUCTURES, AND SHALL ASSUME ALL LIABILITY FOR DAMAGE TO THEM.

NOTES:
 - ALL ROLL NUMBERS IN BEGIN WITH 41-07-110-00
 ie. 00-2115-000 IN FULL IS
 41-07-110-00-2115-000

BENCHMARKS
BM#1
 SPIKE IN SOUTH FACE OF H.P. #BB6NAX
 NORTH SIDE OF SOUTH KINLOSS ROAD
 25m WEST OF TWIN ROAD CULVERTS
 ELEV. 305.046m

- LEGEND**
- - - - - WATERSHED
 - - - - - SUBWATERSHED
 - - - - - PROPOSED WORK OR INCORPORATION
 - - - - - EXISTING DRAIN
 - - - - - DITCH OR WATERCOURSE
 - ACCESS
 - Z - DENOTES PROPERTY OWNERSHIP ON BOTH SIDES OF LOT LINE
 - (5.6) - APPROXIMATE HECTARES IN WATERSHED
 - 00-2116-000 - ASSESSMENT ROLL NUMBER
 - [Shaded Area] - BUSH/WETLAND/WATER BODIES
 - [Hatched Area] - AREA TILED AND DIRECTION
 - * * * * - 1929 GAUNT-LAIDLAW DRAIN TO BE ABANDONED

NO.	DESCRIPTION	DATE
1	ISSUED FOR MVCA APPROVAL	2023-04-08
2	ISSUED FOR DFO APPROVAL	2023-05-04
3	ISSUED FOR TENDER	
4	ISSUED FOR CONSTRUCTION	
5	AS BUILT	

DESIGNED BY: N.W.M.
 CHECKED BY: N.M.W.
 DRAWN BY: N.M.B.
 CHECKED BY: N.W.M.

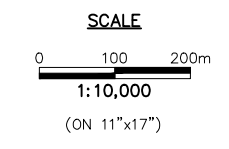
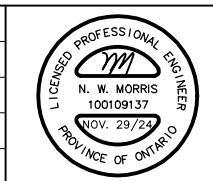

GAUNT - LAIDLAW MUNICIPAL DRAIN
 BRUCE COUNTY
 TOWNSHIP OF HURON-KINLOSS
 (FORMER TOWNSHIP OF KINLOSS)

WATERSHED PLAN NOV. 29, 2024

K. SMART ASSOCIATES LIMITED
 CONSULTING ENGINEERS AND PLANNERS
 KITCHENER SUDBURY

REVISED:
 JOB NUMBER: **22-160**
 DRAWING
1 OF 7

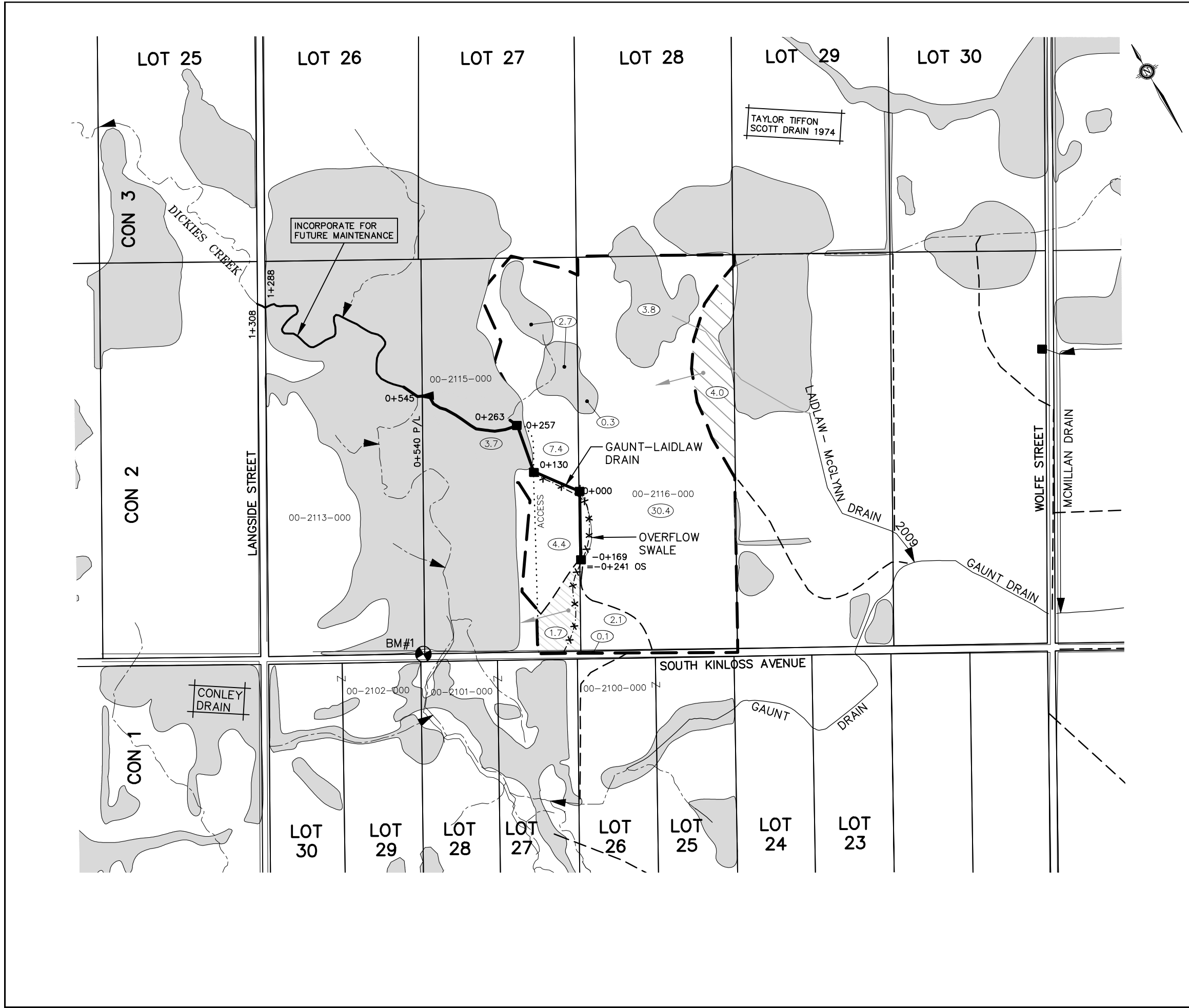

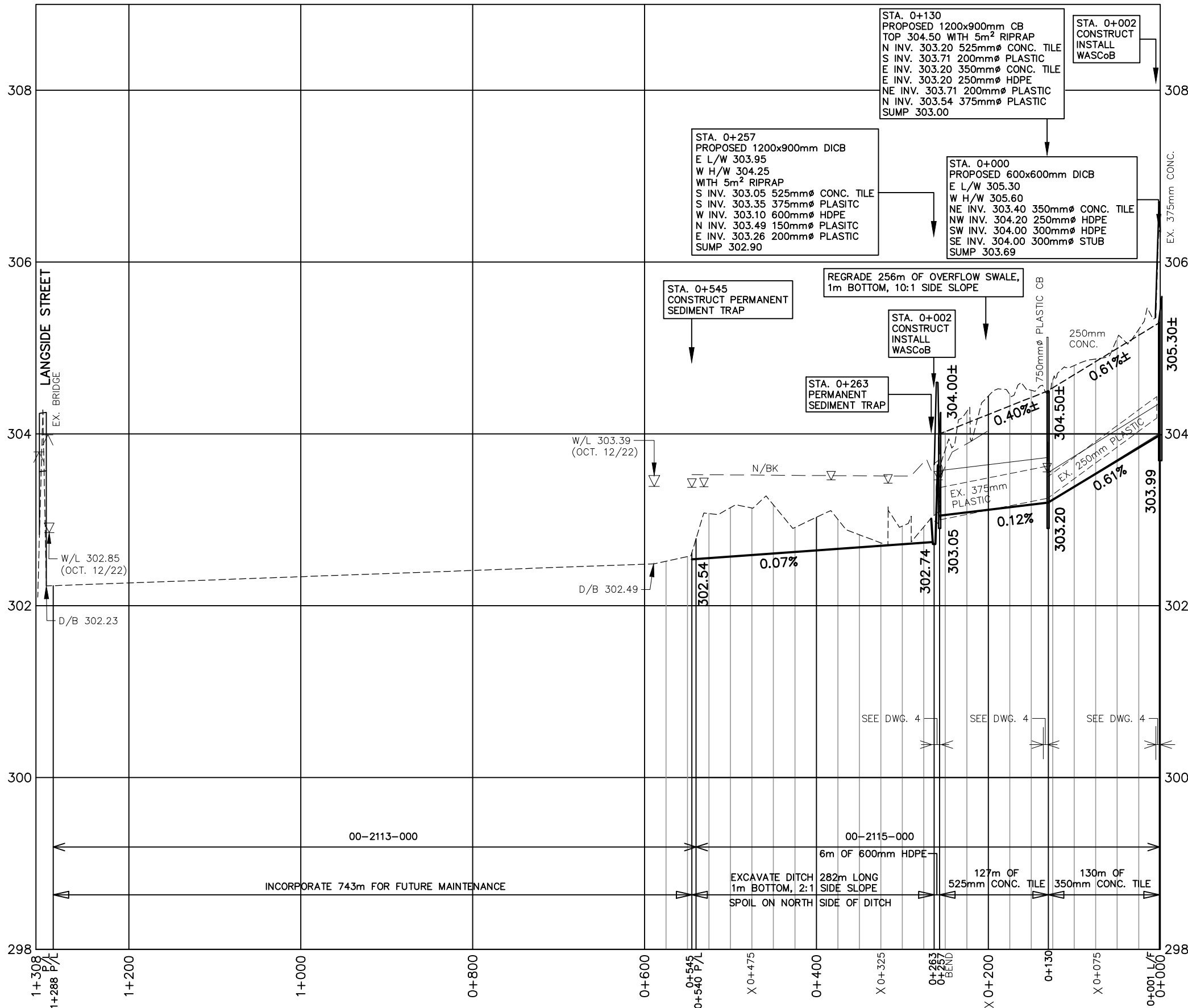

PROFILE

SPECIAL PROVISIONS – CONSTRUCTION NOTES

00+2116–000

0+001 TO 0+130 RE GRADE 129m OF OVERFLOW SWALE, 1m BOTTOM, 1:10 SIDE SLOPE

0+000 TO 0+130 INSTALL 130m OF 350mm CONCRETE TILE

0+130 TO 0+257 RE GRADE 127m OVERFLOW SWALE, 1m BOTTOM, 10:1 SIDE SLOPE

0+130 TO 0+257 INSTALL 127m OF 525mm CONCRETE TILE

0+260 TO 0+266 PLACE 10m² RIPRAP, 5:1 TAPER

0+260 TO 0+298 BRUSHING ALONG NORTH DITCH 10m WIDE

0+251 TO 0+257 INSTALL 6m OF 600mm HDPE

0+251 TO 0+257 FILL IN 6m OF EXISTING DITCH

0+266 TO 0+271 CONSTRUCT PERMANENT SEDIMENT TRAP WITH 10m² OF RIPRAP

0+263 TO 0+545 EXCAVATE DITCH 282m LONG, 1m BOTTOM, 2:1 SIDE SLOPE SPOIL ON NORTH SIDE OF DITCH

00–2113–000

0+545 CONSTRUCT PERMANENT SEDIMENT TRAP WITH 5m² OF RIPRAP AND STRAWBALE DAM

0+545 TO 1+288 INCORPORATE 743m OF EXISTING STREAM FOR FUTURE MAINTENANCE

▽ WATER LEVEL SURVEYED ON OCT. 12, 2022

NO.	DESCRIPTION	DATE
1	ISSUED FOR MVCA APPROVALS	2023–04–08
2	ISSUED FOR DFO APPROVALS	2023–05–04
3	ISSUED FOR TENDER	
4	ISSUED FOR CONSTRUCTION	
5	AS BUILT	

DESIGNED BY: N.W.M.		<p>SCALE</p> <p>0 50 100m</p> <p>1:5000 (HORZ.)</p> <p>0 0.5 1m</p> <p>1:50 (VERT.)</p> <p>(ON 11"x17")</p>
CHECKED BY: N.W.M.		
DRAWN BY: N.M.B.		
CHECKED BY: N.W.M.		

GAUNT - LAIDLAW MUNICIPAL DRAIN
 BRUCE COUNTY TOWNSHIP OF HURON-KINLOSS (FORMER TOWNSHIP OF KINLOSS)

OPEN DITCH PROFILE	NOV. 29, 2024
<p>K. SMART ASSOCIATES LIMITED CONSULTING ENGINEERS AND PLANNERS KITCHENER SUDBURY</p>	REVISED: JOB NUMBER: 22-160 DRAWING 2 OF 7

STA. 0+000
 PROPOSED 600x600mm DICB
 LOW WALL 305.30
 HIGH WALL 305.60
 NE INV. 304.00 350mm \varnothing CONC. TILE
 NW INV. 304.20 250mm \varnothing HDPE
 SW INV. 304.00 150mm \varnothing HDPE
 SE INV. 304.00 300mm \varnothing STUB
 SUMP 303.70

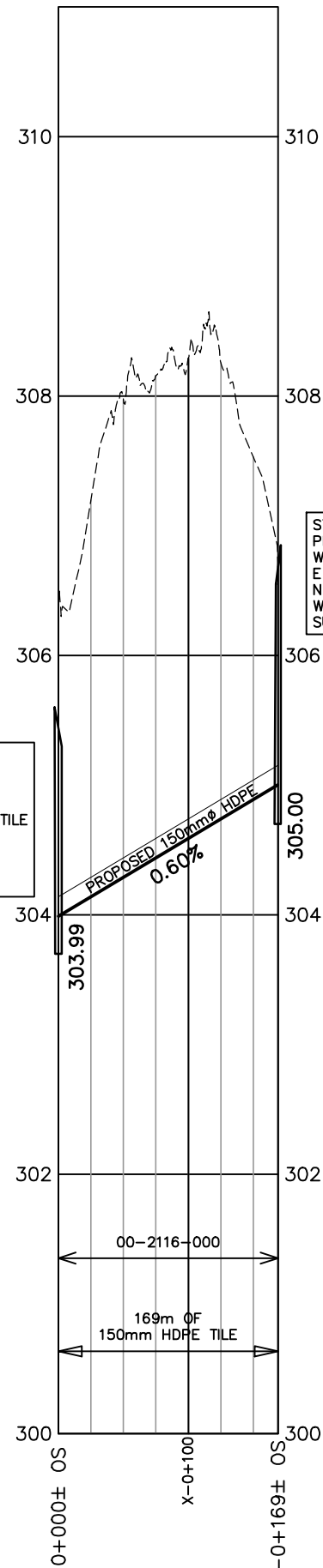

PROFILE - TILE

STA. -0+169 = -0+241 OS
 PROPOSED 600x600mm DICB
 W LOW WALL 306.55
 E HIGH WALL 306.85
 NE INV. 305.00 150mm \varnothing HDPE
 W INV. 305.00 150mm \varnothing STUB
 SUMP 304.70

STA. 0+000
 PROPOSED 600x600mm DICB
 LOW WALL 305.30
 HIGH WALL 305.60
 NE INV. 304.00 350mm \varnothing CONC. TILE
 NW INV. 304.20 250mm \varnothing HDPE
 SW INV. 304.00 150mm \varnothing HDPE
 SE INV. 304.00 300mm \varnothing STUB
 SUMP 303.70

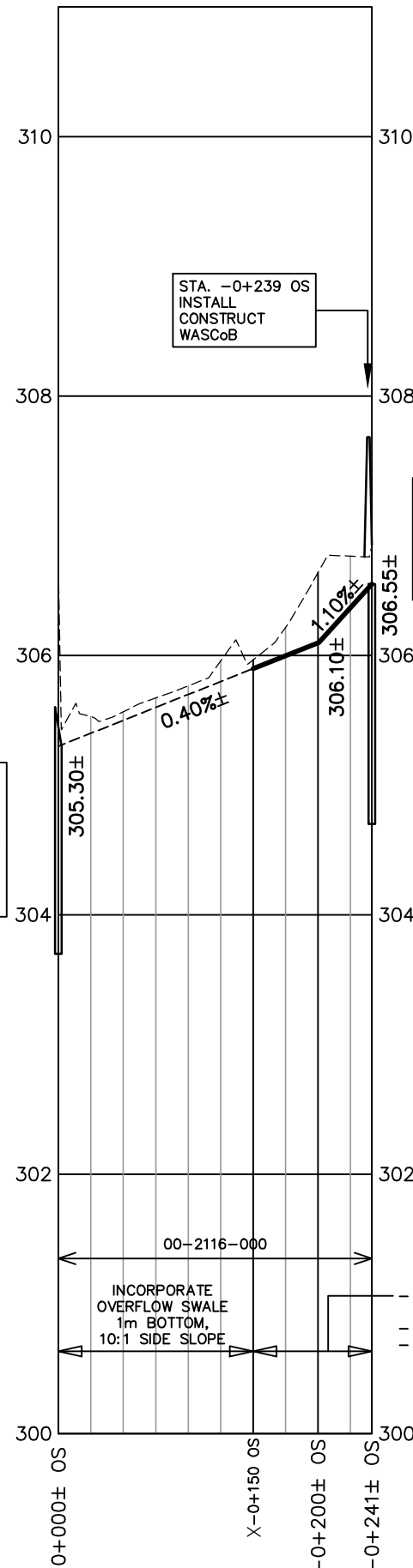

PROFILE - OVERFLOW SWALE

STA. -0+239 OS
 INSTALL
 CONSTRUCT
 WASCob

STA. -0+241 OS = -0+169
 PROPOSED 600x600mm DICB
 W LOW WALL 306.55
 E HIGH WALL 306.85
 NE INV. 305.00 150mm \varnothing HDPE
 W INV. 305.00 150mm \varnothing STUB
 SUMP 304.70

INCORPORATE
 OVERFLOW SWALE
 1m BOTTOM,
 10:1 SIDE SLOPE

REGRADE 91m OF EXISTING SWALE
 1m BOTTOM, 10:1 SIDE SLOPE
 SPOIL ON WEST SIDE OF DRAIN
 SEED SWALE 910m²

SPECIAL PROVISIONS - CONSTRUCTION NOTES

- 0+000 TO -0+169 INSTALL 169m OF PERFORATED WITH 150mm \varnothing HDPE PIPE
- 0+000 TO -0+150 OS INCORPORATE OVERFLOW SWALE GRADE FOR FUTURE MAINTENANCE
- 0+150 OS TO -0+241 OS REGRADE 91m EXISTING SWALE 1m BOTTOM, 10:1 SIDE SLOPE, PLACE SPOIL ON WEST SIDE OF DRAIN SEED 910m² DISTURBED AREA 10m WIDTH

NO.	DESCRIPTION	DATE
1	ISSUED FOR MVCA APPROVALS	2023-04-08
2	ISSUED FOR DFO APPROVALS	2023-05-04
3	ISSUED FOR TENDER	
4	ISSUED FOR CONSTRUCTION	
5	AS BUILT	

DESIGNED BY: N.W.M.
 CHECKED BY: N.W.M.
 DRAWN BY: N.M.B.
 CHECKED BY: N.W.M.

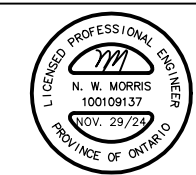

SCALE
 0 50 100m
1:5000 (HORZ.)
 0 0.5 1m
1:50 (VERT.)
 (ON 11"x17")

GAUNT - LAIDLAW MUNICIPAL DRAIN
 BRUCE COUNTY TOWNSHIP OF HURON-KINLOSS (FORMER TOWNSHIP OF KINLOSS)

EXTENSION PROFILE	NOV. 29, 2024
	REVISED:
K. SMART ASSOCIATES LIMITED CONSULTING ENGINEERS AND PLANNERS KITCHENER SUDBURY	JOB NUMBER: 22-160
	DRAWING 3 OF 7

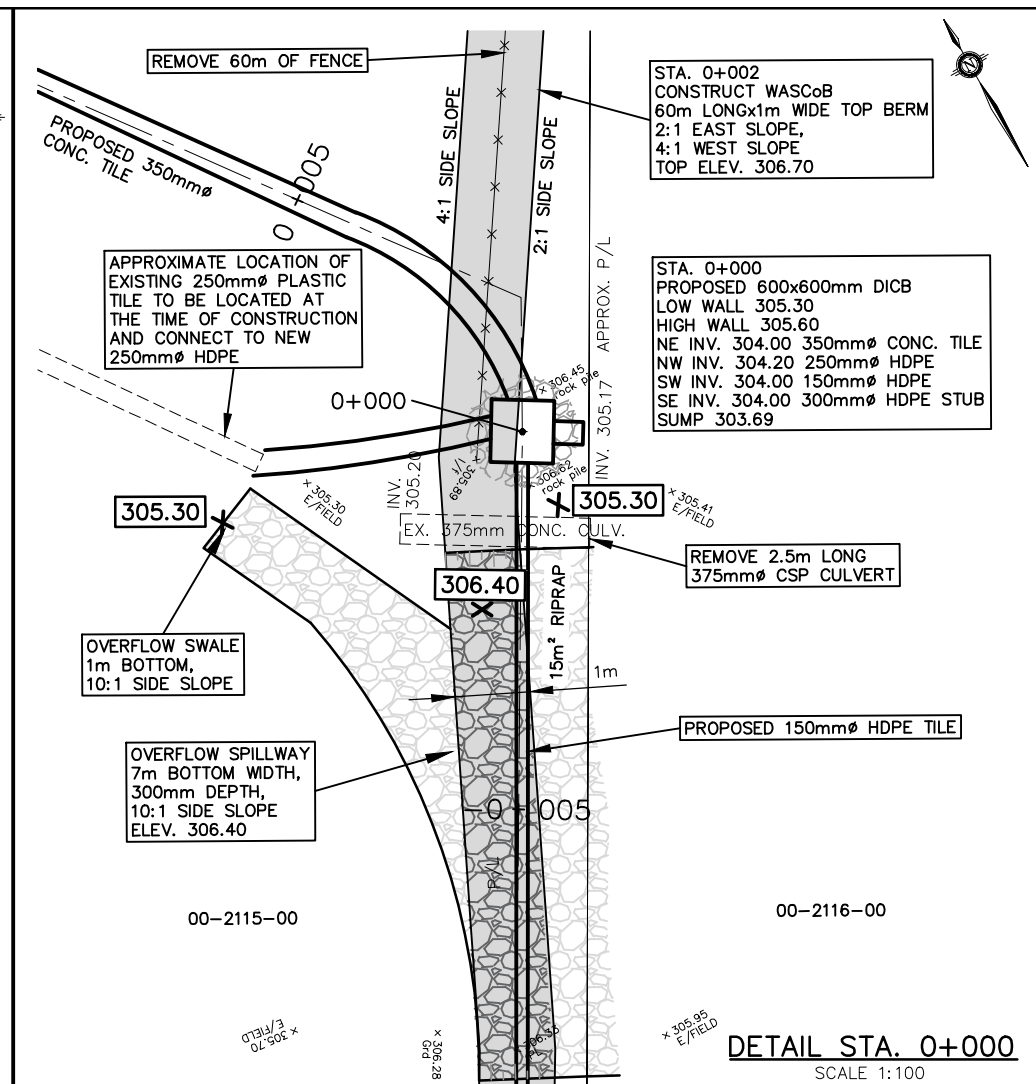
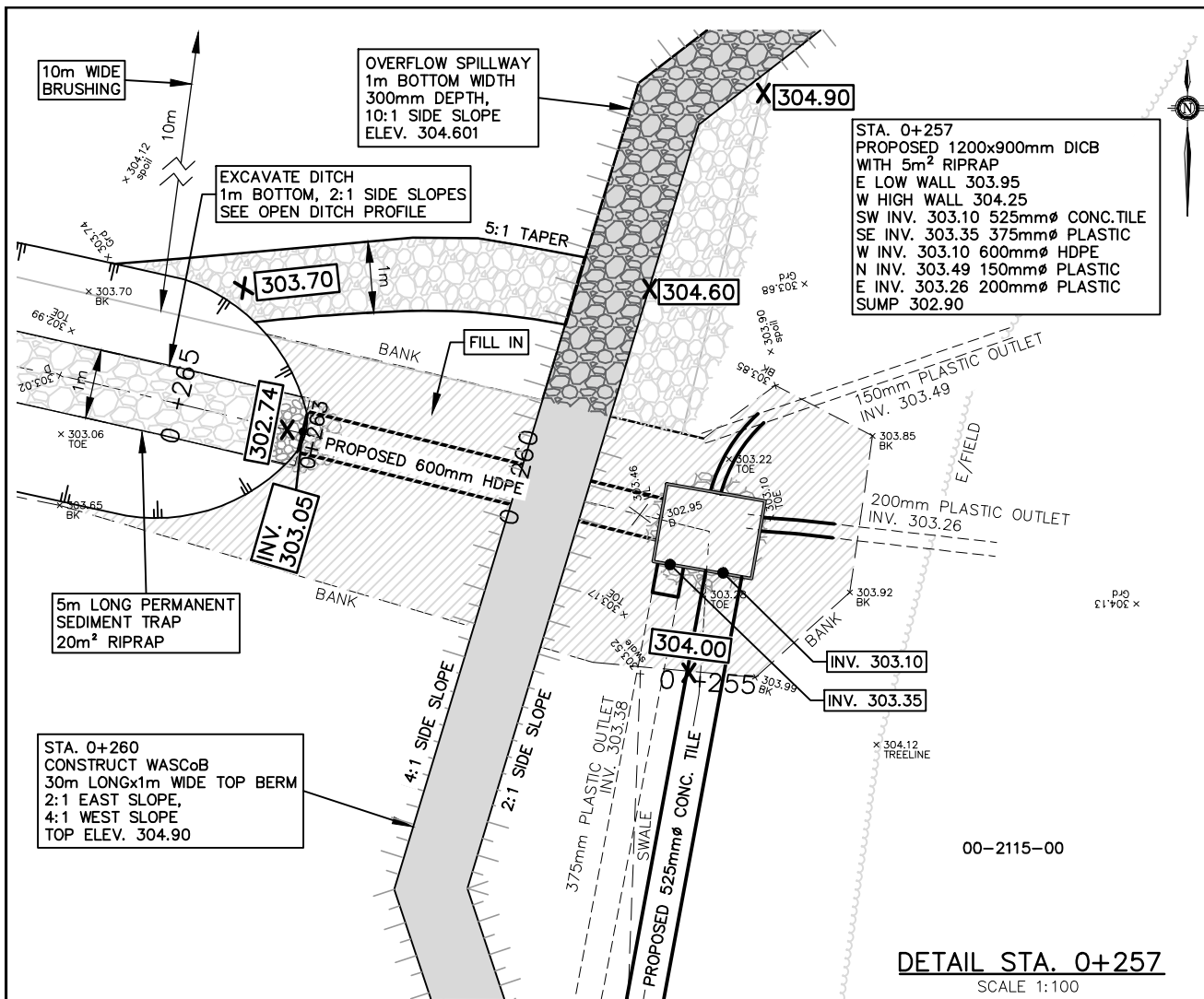

SPECIAL PROVISIONS – CONSTRUCTION NOTES

-0+001	REMOVE 2.5m LONG CULVERT OF 375mm ϕ CSP
0+000	CONSTRUCT 600x600mm DICB WITH BIRDCAGE GRATE, CONNECT EXISTING TILE AND 5m ² RIPRAP AROUND DICB
0+002	REMOVE 60m OF FENCE
0+002	CONSTRUCT WASCob 60m LONGx1m WIDE, 2:1 EAST SLOPE, 4:1 WEST SLOPE WITH OVERFLOW SPILLWAY 1m BOTTOM WIDTH, 300mm DEPTH, 10:1 SIDE SLOPE WITH 15m ² RIPRAP LOCATE EXISTING 250mm ϕ TILE AND CONNECT NEW 250mm ϕ HDPE
0+257	CONSTRUCT 1200x900mm DICB WITH 5m ² RIPRAP AROUND CB WITH BIRDCAGE GRATE
0+260 TO 0+266	PLACE 10m ² RIPRAP, 5:1 TAPER
0+260 TO 0+548	BRUSHING ALONG NORTH DITCH 10m WIDE
0+257 TO 0+263	FILL IN 6m OF EXISTING DITCH
0+260 TO 0+271	CONSTRUCT PERMANENT SEDIMENT TRAP WITH 10m ² OF RIPRAP
0+260	CONSTRUCT WASCob 30m LONG 1m WIDE, 2:1 EAST SLOPE, 4:1 WEST SLOPE WITH OVERFLOW SPILLWAY 1m BOTTOM WIDTH, 300mm DEPTH
-0+169	CONSTRUCT 600x600mm DICB WITH 5m ² RIPRAP AROUND CB WITH BIRDCAGE GRATE
-0+239 OS	CONSTRUCT WASCob 38m LONG 1m WIDE, 2:1 FRONT SLOPE, 4:1 BACK SLOPE WITH OVERFLOW SPILLWAY 1m BOTTOM WIDTH, 300mm DEPTH, 10:1 SIDE SLOPE WITH 15m ² RIPRAP
0+123 TO 0+124	PLACE 6m ² OF RIPRAP ACROSS LANEWAY 6m WIDE
0+130	CONSTRUCT 1200x900mm CB WITH 5m ² RIPRAP AROUND WITH BIRD GRATE GRATE AND CONNECT EXISTING TILE TO CB
0+131	REMOVE EXISTING 750mm ϕ CB

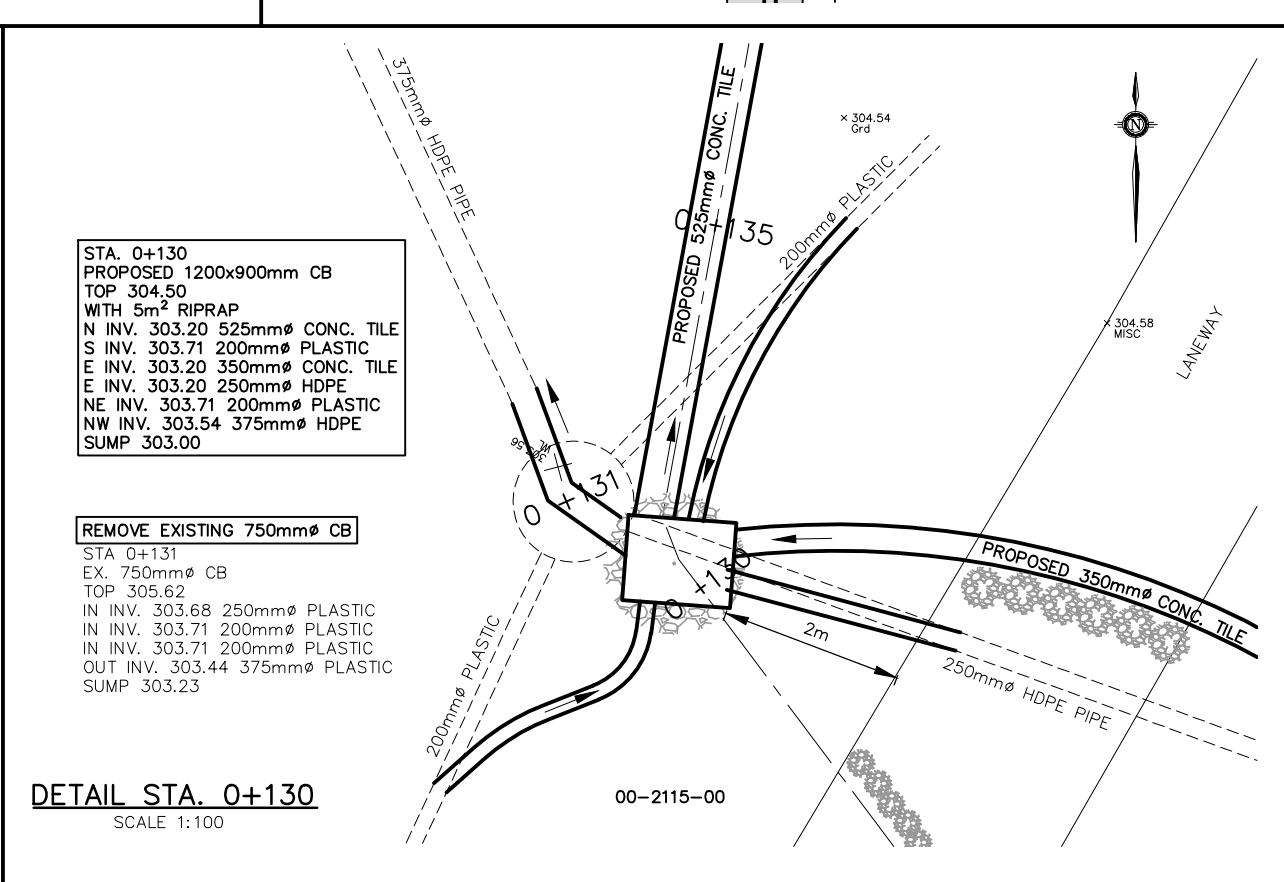
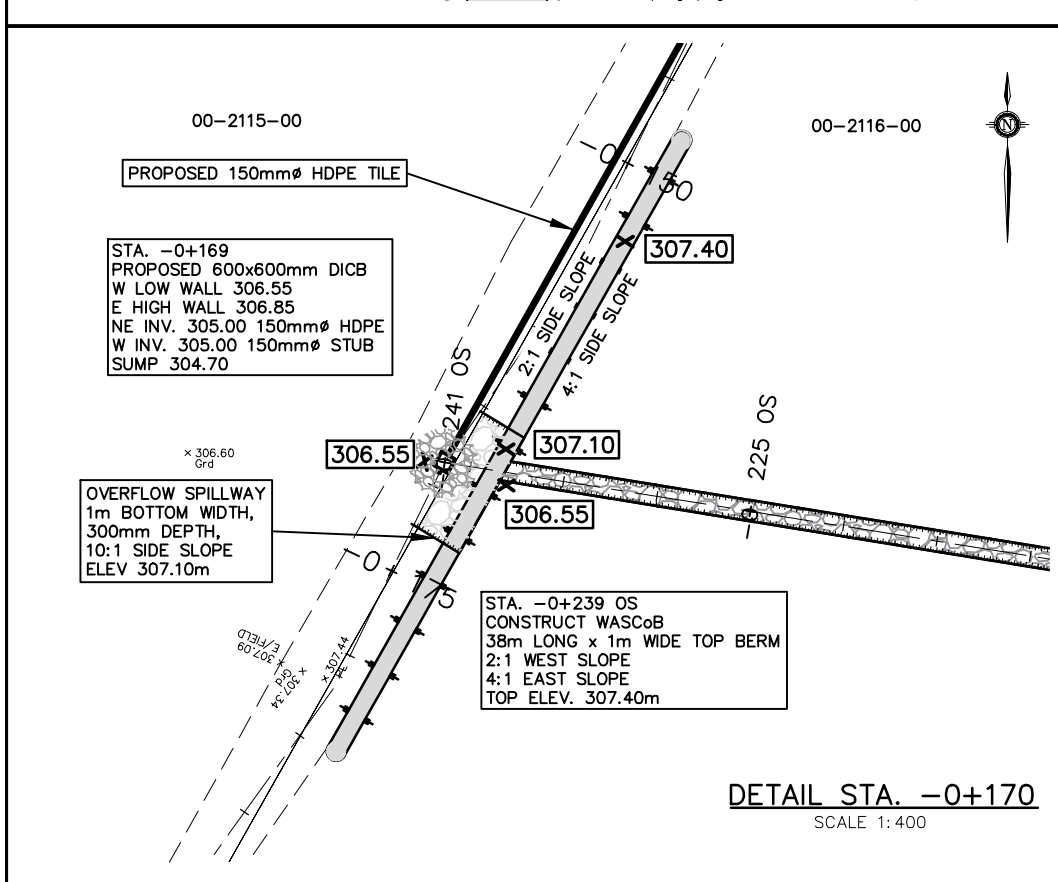

NO.	DESCRIPTION	DATE
1	ISSUED FOR MVCA APPROVALS	2023-04-08
2	ISSUED FOR DFO APPROVALS	2023-05-04
3	ISSUED FOR TENDER	
4	ISSUED FOR CONSTRUCTION	
5	AS BUILT	

DESIGNED BY: N.W.M.
 CHECKED BY: N.W.M.
 DRAWN BY: N.M.B.
 CHECKED BY: N.W.M.

SCALE
 0 1 2m
 1 : 100
 (ON 11"x17")

GAUNT - LAIDLAW MUNICIPAL DRAIN
 BRUCE COUNTY TOWNSHIP OF HURON-KINLOSS (FORMER TOWNSHIP OF KINLOSS)

DETAILS	NOV. 29, 2024
	REVISED: JOB NUMBER: 22-160 DRAWING: 4 OF 7

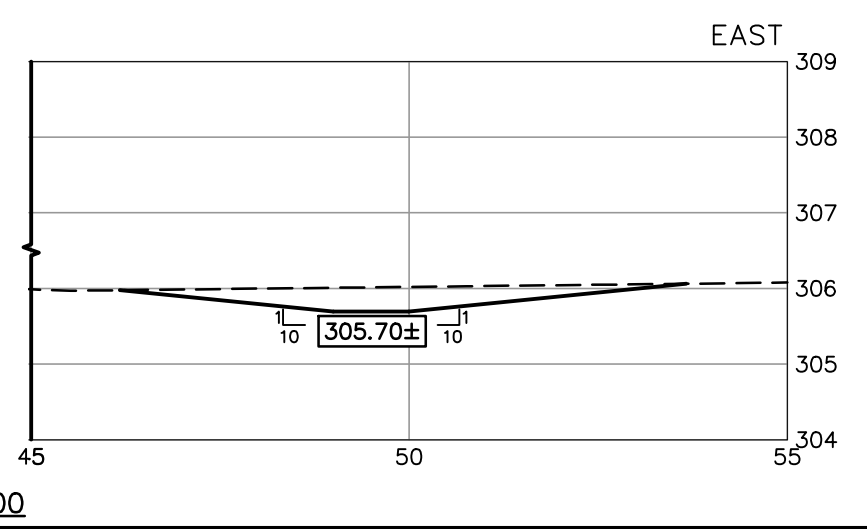
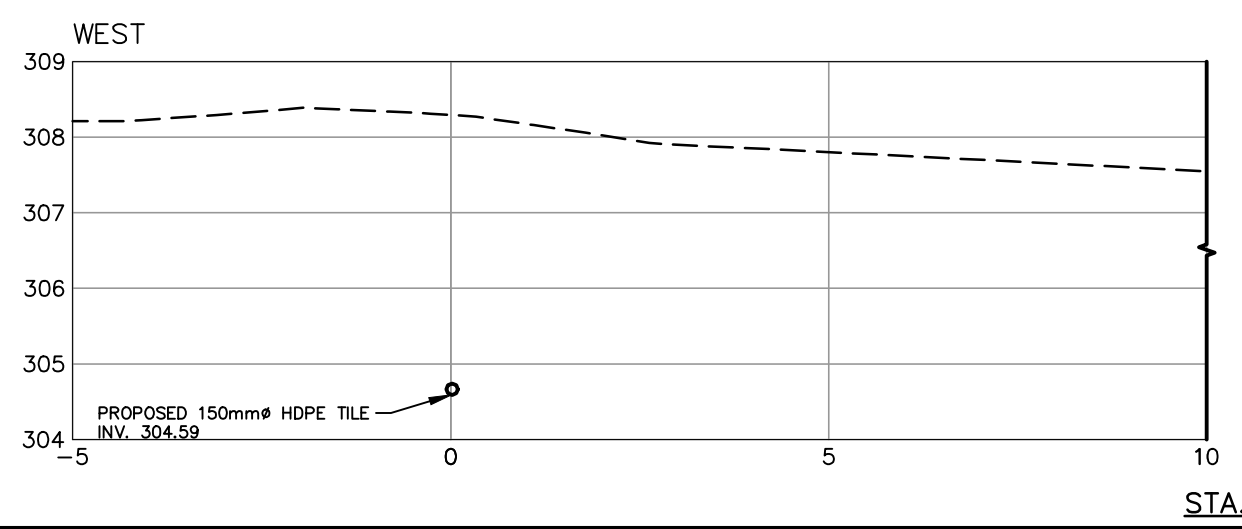
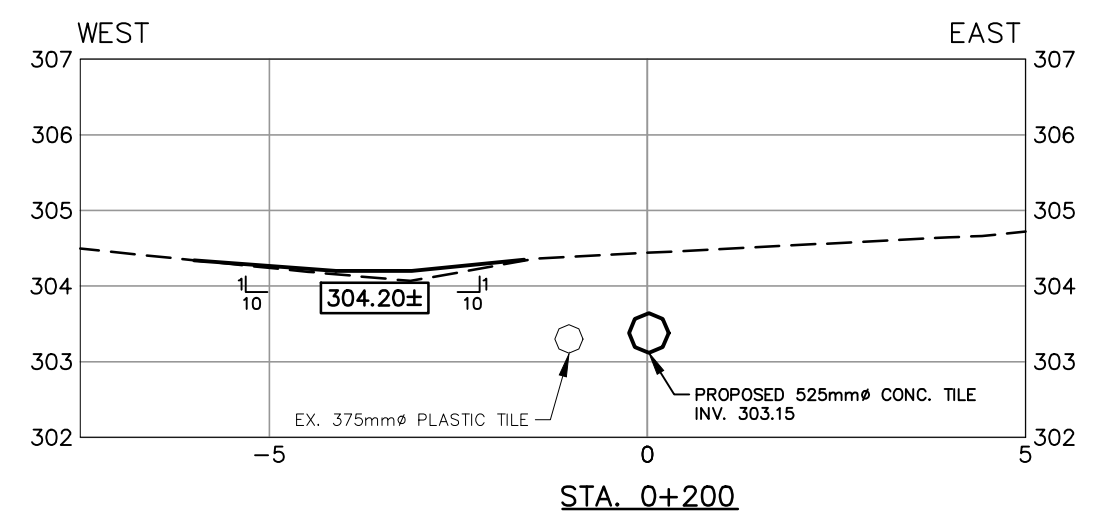
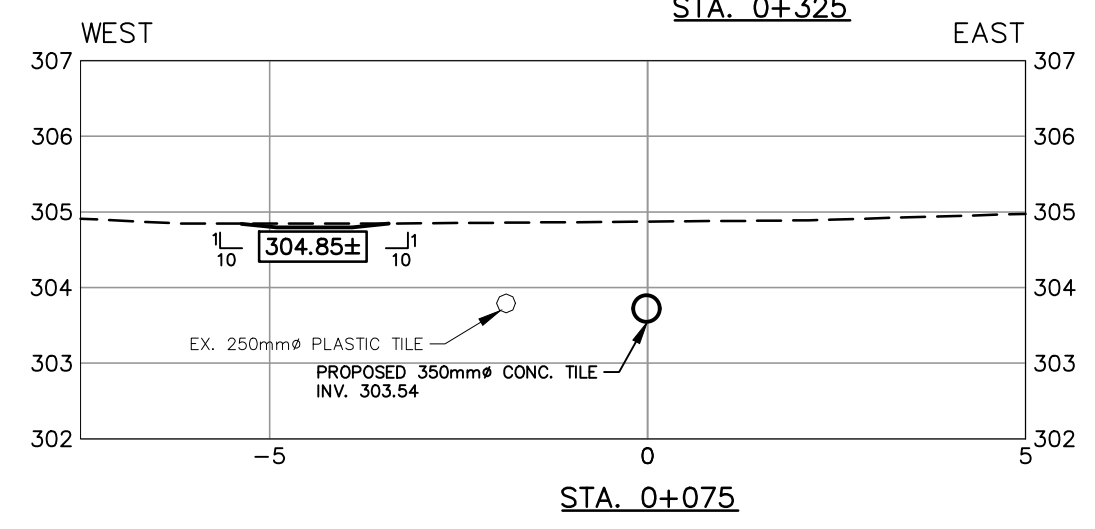
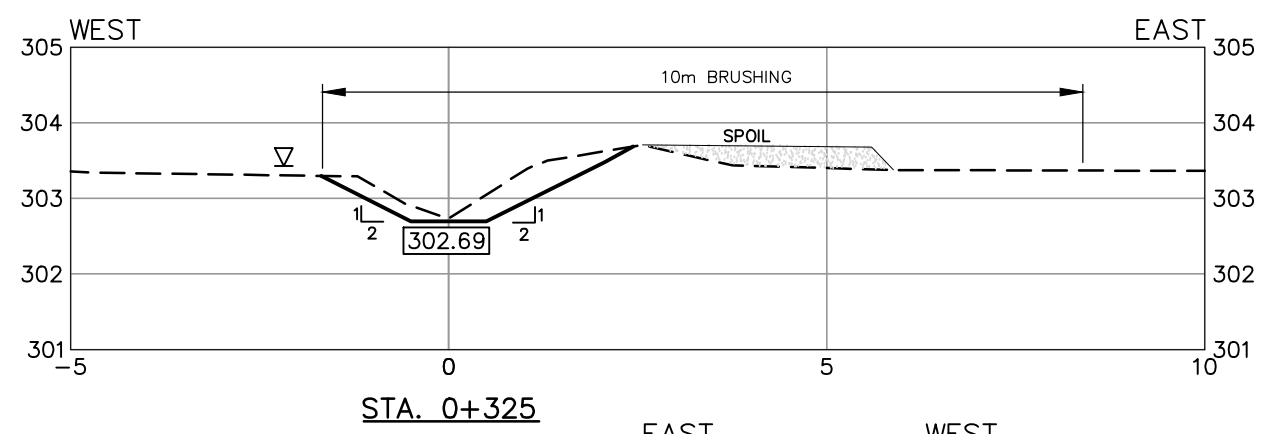
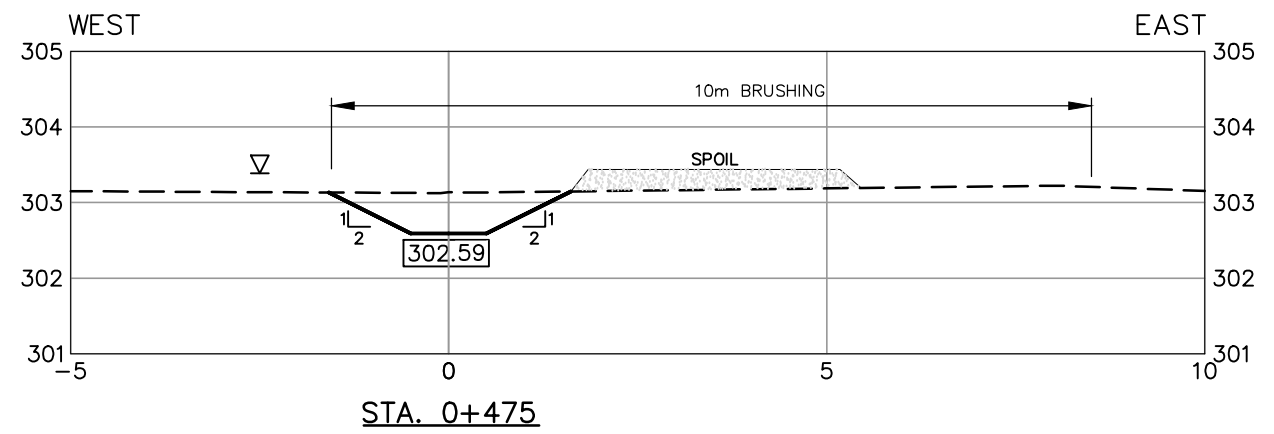

SPECIAL PROVISIONS – CONSTRUCTION NOTES

▽ WATER LEVEL SURVEYED ON OCT. 12, 2022

NO.	DESCRIPTION	DATE
1	ISSUED FOR MVCA APPROVALS	2023-04-08
2	ISSUED FOR DFO APPROVALS	2023-05-04
3	ISSUED FOR TENDER	
4	ISSUED FOR CONSTRUCTION	
5	AS BUILT	

DESIGNED BY: N.W.M.		SCALE 0 50 100m 1 : 100 (HORZ.) 0 0.5 1m 1 : 100 (VERT.) (ON 11"x17")
CHECKED BY: N.W.M.		
DRAWN BY: N.M.B.		
CHECKED BY: N.W.M.		

GAUNT - LAIDLAW MUNICIPAL DRAIN
 BRUCE COUNTY TOWNSHIP OF HURON-KINLOSS (FORMER TOWNSHIP OF KINLOSS)

CROSS SECTIONS **NOV. 29, 2024**

	REVISED:
	JOB NUMBER: 22-160
	DRAWING 5 OF 7

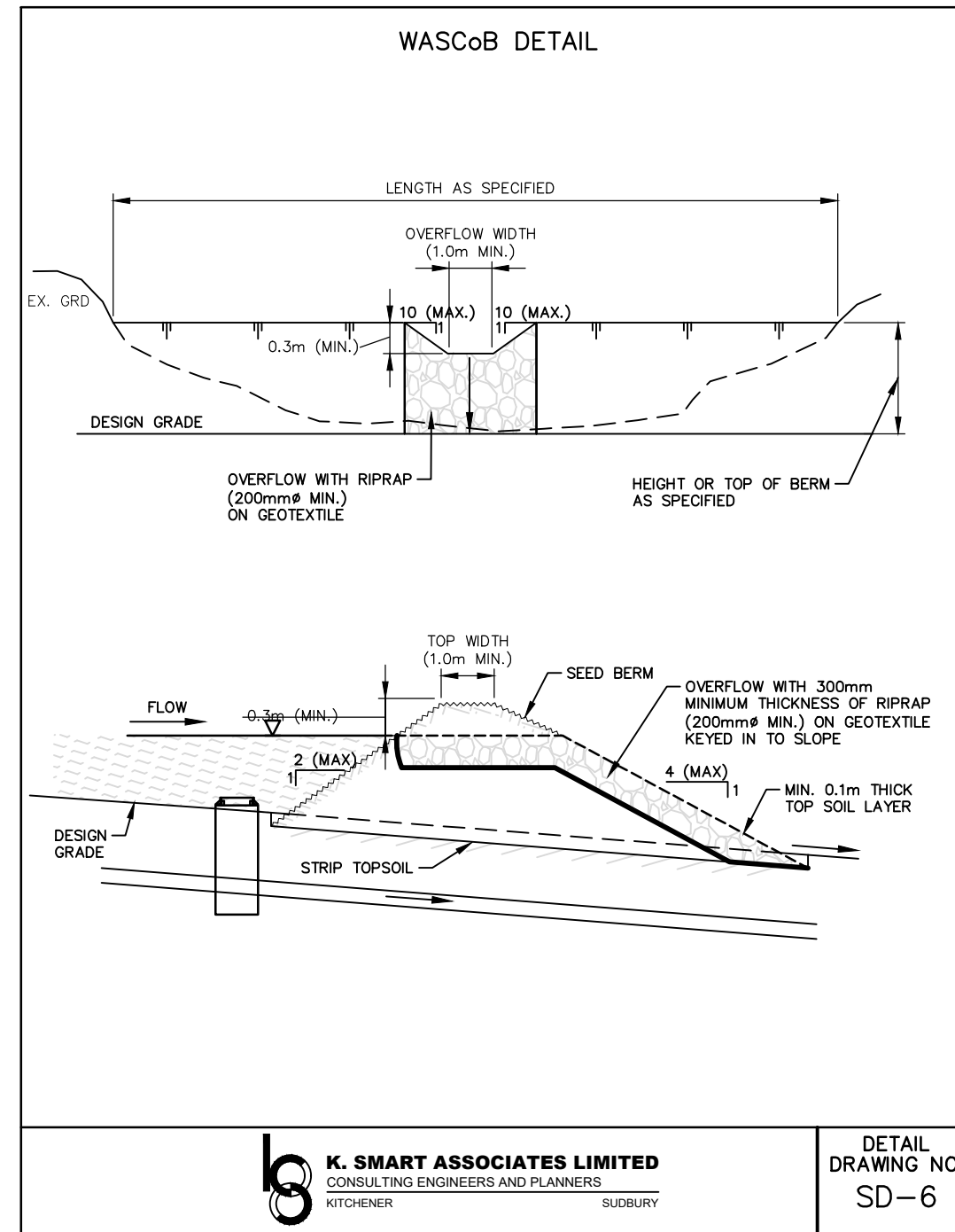
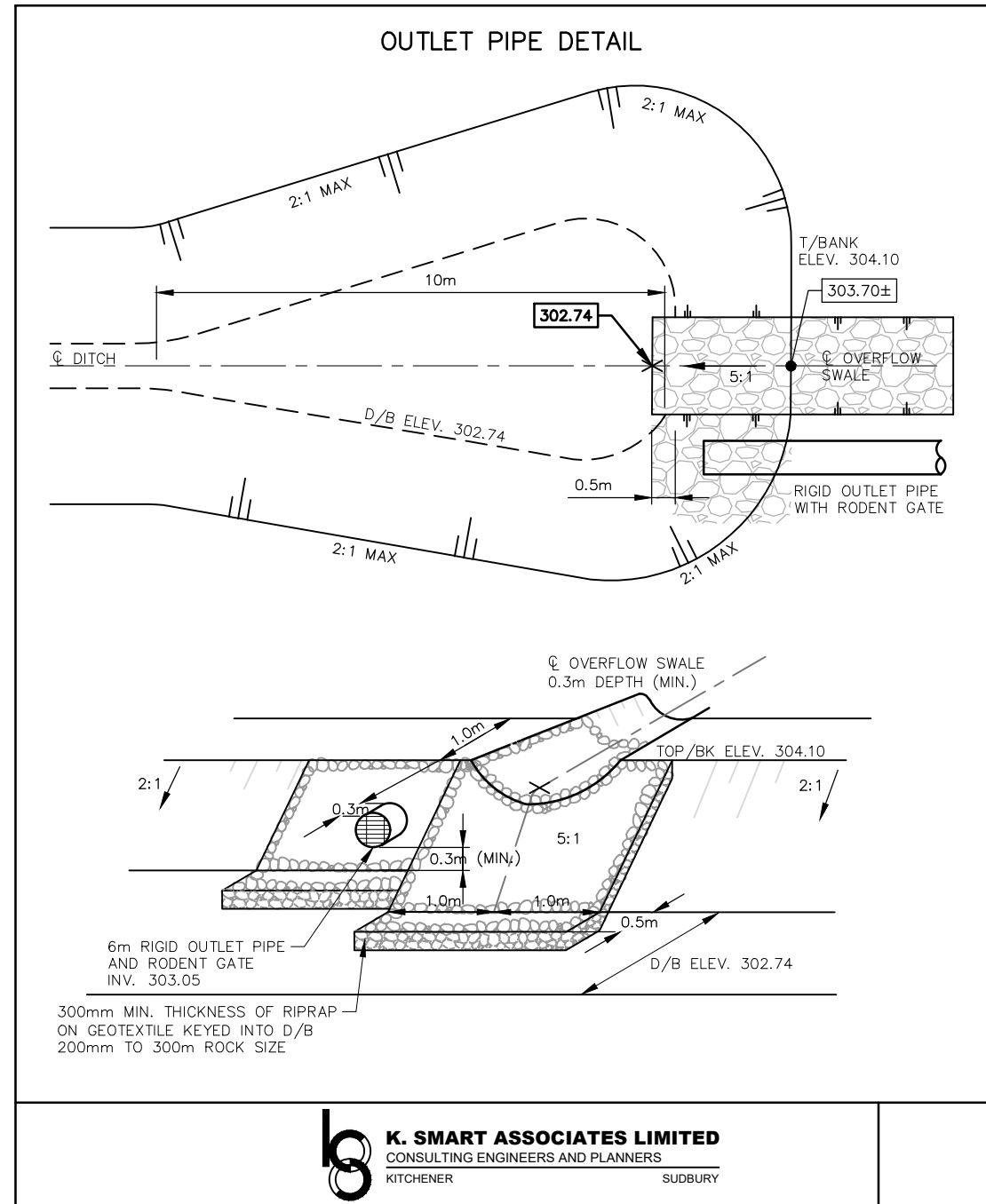

GAUNT - LAIDLAW MUNICIPAL DRAIN
BRUCE COUNTY TOWNSHIP OF HURON-KINLOSS (FORMER TOWNSHIP OF KINLOSS)

DESIGNED BY: N.W.M.
CHECKED BY: N.W.M.
DRAWN BY: N.M.B.
CHECKED BY: N.W.M.



NOT TO SCALE

K. SMART ASSOCIATES LIMITED
CONSULTING ENGINEERS AND PLANNERS
KITCHENER SUDBURY

NOV. 29, 2024

REVISED:
JOB NUMBER: **22-160**
DRAWING
6 OF 7

300) CONSTRUCTION NOTES (SPECIAL PROVISIONS)

300.1) SPECIFIC NOTES

Refer to Special Provisions Specific Notes on Drawings 2 to 3.

300.2) PROJECT NOTES

300.2.1) Working Area

For a closed drain up to 2m deep, the working area shall be 10m width on either side of the trench or any combination not exceeding 20m in width. If any part of the drain is close to a property line, then the property line shall be one of the limits of the work area. Any part of the drain is in the road allowance; the road allowance shall be the working area. Restricted or increased working areas would be described in detail in the specific construction notes. Refer to Section 400.4 of Standard Specifications for Construction of Drains for exceptions.

300.2.2) Access

The Contractor shall have access to the drain along the routes, if any, shown in Drawing 1. The access routes shall be along existing laneways or paths or where none exist, along a 6m wide (maximum) path. No other access routes shall be used unless first approved by the Engineer and affected landowners. The Contractor shall also contact each owner before using designated accesses. Refer to Section 400.5 of the Standard Specifications for the Construction of Drains. Telephone numbers for contacts are:

Roll No.	Owner(s)	Phone Numbers for landowners To be provided at the time of construction
Drainage Superintendent	Ken McCallum Huron-Kinloss	(519) 395-3735
Engineer	Neal Morris, P. Eng.	(519) 748-1199 x 240
002-113	E. Martin	
002-115	H. Martin	
002-116	M. Metske	

300.2.3) Soils Considerations

The Bruce County soils mapping for this area indicates that the soils adjacent to this Drain are Fox Sandy Loam with Muck soils in low and open ditch areas. Based on available information, adverse subsurface and soil should be anticipated. New tile may be placed into saturated sandy soils.

Clear stone and filter fabric riprap may be required in poor-subsoil conditions.

It is to be anticipated that the open ditch is constructed in Muck soils. Muck soil has a low bearing capacity and are saturated soils. Work in the winter or in the summer dry, is recommended. Construction equipment most likely would be required to be supported with mats or trees during construction.

Refer to the Standard Specifications for drain construction procedures when adverse subsurface conditions are encountered.

Refer to Section 400.9 of Standard Specifications for drain construction procedures when adverse subsurface conditions are encountered.

300.2.4) Environmental

The following agencies have been notified of the project:

Maitland Valley Conservation Authority

- MVCA indicated that there were no major concerns with the proposed work but require a copy of the submitted Engineer's report before finalizing the permit.

DFO

- A letter of advice, dated June 8, 2023, advised that work can occur between July 15 and March 15 with the following provisions:
 - Limit access to banks or areas adjacent to waterbodies.
 - Vegetate the disturbed area with native species suitable for open ditch.
 - Conduct all in-water works, undertakings or activities in isolation of open or flowing water to reduce the introduction of sediment into the watercourse.
 - Work in open ditch is not to occur in rainy, spring melt, stormy and windy weather.
 - Monitor the watercourse to observe signs of sedimentation during all phases of the work, undertaking or activity and take corrective action.
 - Place existing stream bed and bank material in bank in ditch after work is completed.
 - Contractor is to clean equipment and have a spill kit on-site before working in open ditch.

MECP

- There are no SAR anticipated in the area of proposed work.

300.2.5) Pre-Construction Approvals

Before starting work, the Contractor shall ensure all public utilities are located and shall contact all landowners along the proposed drain

route to determine the location of any private utilities. Permits are not required for the proposed work.

300.2.6) Seed Mix

Native Woodland Seed Mix to be used from Station 0+257 to 0+545. Woodland Native Seed Mix (Apply at a rate of 25kg/ha, plant between October 15 and November 15)

Cover Crop seed mix to be used upstream, of station 0+257. Cover Crop: (Apply at a rate of 15kg/ha)

- If seeding in Spring/ Summer, 40% Oats, 45% Barley, and 15% Canada Wild Rye
- If seeding in the Fall, 100% winter wheat

300.2.7) Fencing

All fences are to be removed and re-erected by the Contractor unless described otherwise by notes on the drawings.

Refer to Section 400.24 of the Standard Specifications for the Construction of Drains.

Refer to Section 400.25 re livestock and fences of the Standard Specifications for the Construction of Drains.

